

BWS P/N:40950794 REV: 3



OILFIELD OPERATOR'S MANUAL
DECEMBER 2021

www.bwstrailers.com
toll free 888.896.5777



ISO 9001:2015
CERTIFIED

TABLE OF CONTENTS

INTRODUCTION	4
PRODUCTS	4
BWS COMPANY HISTORY	5
QUALITY POLICY	6
COMPLIANCE PLATE	7
HUB ALERT™	8
1.0 SAFETY PRECAUTIONS	10
1.1 OPERATING SAFETY	11
1.2 MAINTENANCE SAFETY	11
1.3 LOADING SAFETY	11
1.4 SAFETY DECAL MAINTENANCE	11
1.5 SIGN-OFF FORM	11
2.0 SAFETY DECALS	13
3.0 OPERATING PROCEDURES	14
3.1 BREAK-IN/INSPECTION	14
3.1.1 500 mile / 800 km Inspection	14
3.1.2 10,000 mile / 16,000 km Inspection	14
3.1.3 20,000 mile / 32,000 km Inspection	14
3.2 PRE-OPERATION VEHICLE INSPECTION PROCEDURE	15
Walk Around Sequence	15
3.3 FIFTH WHEEL OPERATING INSTRUCTIONS	17
3.3.1 Coupling Procedure	17
3.3.2 Uncoupling Procedure	18
3.4 LOADING	19
3.4.1 Trailer Weight Distribution	19
3.4.2 Load Restraints	20
3.5 TRANSPORTING	20
3.5.1 Braking Guidelines	20
3.5.2 Tires	21
4.0 MAINTENANCE AND INSPECTION	22
4.1 KING PIN AND UPPER COUPLER	23
4.2 AXLES	23
4.2.1 Suggested Preventative Maintenance Schedule	23
4.2.2 Axle Alignment	23
4.2.3 Wheels	24
4.2.4 Wheel Hubs	25
4.2.5 Bearing Adjustment Procedure	26
4.2.6 Bearing Adjustment	27
4.3 GREASE RETAINERS / OIL SEALS	28
4.3.1 Ring and Seal Type (Oil) Maintenance	28
4.3.2 Ring and Seal Type (Oil) Replacement	28
4.4 SUSPENSION SYSTEM (AIR)	29
4.4.1 Inspection	29
4.5 AIR RIDE SUSPENSION	30
4.5.1 Pre-Operation Inspection	30
4.5.2 Air Spring Replacement	31
4.5.3 Shock Absorbers	31

TABLE OF CONTENTS

4.5 AIR RIDE SUSPENSION CONTINUED	
4.5.4 Pivot Bushing	31
4.5.5 Pivot Connection	31
4.5.6 Air Control System	31
4.5.7 Height Control Valve	31
4.5.8 Air Dump Valve	32
4.6 BRAKES	32
4.6.1 Preventative Maintenance	32
4.6.2 Brake Component Identification	32
4.6.3 Brake Component Diagram	33
4.6.4 Slack Adjuster Schematic	35
4.6.5 Haldex Auto Slack Adjuster	36
4.7 TIRES	37
4.7.1 Tire Care and Maintenance	37
4.7.2 Tire Inspection	37
4.7.3 Mechanical Irregularities	38
4.7.4 Radial Tire Application	38
4.7.5 Matching Tires to Rims	38
4.7.6 Tire Wear Patterns:	38
Over Inflation	38
Under Inflation	38
Feathering	38
One Side Wear	38
Cupping	39
Second Rib Wear	39
4.8 AIR SYSTEM COMPONENTS	39
4.8.1 Glad Hands	39
4.8.2 ABS	39
4.9 ELECTRICAL SYSTEM	40
5.0 SCISSORNECK OPERATION	41
6.0 SINGLE AXLE BOOSTER OPERATING INSTRUCTIONS	42
AIR SCHEMATICS	46
BOOSTER	47
SCISSORNECK	48
RIGIDNECK	49
OILFIELD FLOAT	50
OILFIELD JEEP	51
ELECTRICAL SCHEMATICS	52
BOOSTER	53
SCISSORNECK	54
RIGIDNECK	55
OILFIELD FLOAT	56
OILFIELD JEEP	57
7.0 CONTROL BOXES	58
8.0 TROUBLE SHOOTING	61
9.0 WARRANTY	65

INTRODUCTION

The BWS product you have just taken delivery of has been carefully designed and built for easy, low maintenance, reliable operation that meets the requirements of a shrewd transportation industry.

We take this opportunity to thank you for choosing BWS, and assure you of our interest in the continued safe and reliable operation of this equipment through its' dealer and service network abroad. BWS trailers require that you and anyone else who will be operating or maintaining the trailer, read this manual carefully and understand the Safety, Operation, Maintenance and Trouble Shooting information contained in the Operator's Manual.

PRODUCTS

TAG A LONG

- Air Ramp Tilt
- Air Tilt, No Ramp
- Non Tilt Tag
- Flat Deck, Non Tilt

DOUBLE DROP

- Air Detachable Gooseneck
- Air Detachable Gooseneck AG ULP
- Mechanical Detachable Gooseneck
- Mechanical Detachable Gooseneck EXT
- Mechanical Detachable Gooseneck AG ULP
- Hydraulic Detachable Gooseneck AG
- Hydraulic Detachable Gooseneck AG ULP
- Hydraulic Detachable Gooseneck AGNR

HEAVY HAUL

- Hydraulic Detachable Gooseneck
- Hydraulic Detachable Goosneck E
- Hydraulic Detachable Gooseneck H
- Hydraulic Detachable Gooseneck HS
- Flip Axle
- 40-60 Ton Jeep 1/2/3 Axles

FLATS/DROPS

- Highway B-Train
- Highway Flat
- Highway Drop

EQUIPMENT/PAVING/RECOVERY

- Equipment Trailer
- Equipment Trailer Paving & Recovery

OILFIELD

- Rigidneck
- Scissorsneck
- Oilfield Jeep
- Oilfield Float
- Single Axle Booster
- 40 - 60 Ton Jeep 1/2/3 Axles

LOGGING

- Eastern Logger NB/NS/QC
- Eastern Logger NL
- Eastern Logger NL B-Train
- Eastern Logger ON
- Western Logger AB/SK
- Western Logger B-Train
- Western Logger BC

SPECIALIZED

- Cable Reel Trailer
- Nuclear
- Hopper Sander
- U Body Dump
- Turnkey Truck
- Scrap B-Train
- Land Pro
- Pitpro 360 Screener

DUMPS

- Dump Trailer
- Live Bottom

BWS COMPANY HISTORY

Our Trailers are engineered, designed and manufactured by BWS, located in Centreville, New Brunswick. It is a family owned and managed business that is dedicated and committed to delivering outstanding value. Its success is built on thinking like the customer and producing trailers that can be relied on year after year without fail.

Since 1967, it has gained and maintained the trust and respect of experienced customers who work in the oil fields, construction, equipment and machinery moving, forestry, road building, paving and private contracting industries.

Originally BWS manufactured custom trailers with a focus on forestry and agriculture. Having built a solid reputation in this rough off-road industry and operating in the tough Canadian environment, BWS continues today to manufacture trailers that are designed to meet the customers' expectations in the environments in which they operate. The units are designed to go to work and stay at work.

BWS has expanded its product line into areas where it can continue to provide high quality solutions that deliver value.

The employees of BWS are a dedicated workforce with a "craftsman" mentality. Many of its senior people have past experience operating trailers and equipment and this has resulted in their philosophy of putting themselves in the shoes of their customers. BWS relies heavily on feedback from both their dealers and their customers. We build what performs, not just what sells and that is what has contributed to our significant growth throughout North America over the last several years.





CERTIFIED
CSA W47.1



QUALITY POLICY

BWS Manufacturing is totally committed to understanding and meeting the quality needs and expectations of all our customers. Our company has a proud reputation for delivering quality equipment and components.

BWS strives for continuous improvement of our product and meeting the objectives of the company. We are also committed to the continuous improvement of our quality management system to insure its suitability to meet all company, customer, regulatory, legal and ISO requirements.

The entire BWS team will adhere to the spirit and intent of our quality policy, as well as the directives of this quality assurance manual and its supporting quality system documentation. We will continue to aggressively strive to insure that customer satisfaction is achieved at all times, and in all things.

Hugo St-Cyr
CEO
Jamie Merrithew
Systems Manager



COMPLIANCE PLATE

The compliance plate is located on the road side of the trailer frame. The National Safety Mark (NSM) verifies compliance with all applicable Canadian Motor Vehicle Safety Standards (CMVSS) and/or American Federal Motor Vehicle Safety Standards (FMVSS), and records the following information.

- V.I.N.** Vehicle Identification Number
- DATE** Date of Manufacture
- TYPE** (TRA/REM) in Canada only
- MODEL** BWS Trailer Model
- G.V.W.R** Gross Vehicle Weight Rating is the sum of the trailer weight and the allowable trailer load.
- G.A.W.R** Gross Axle Weight Rating is the lowest capacity of all the individual components in the axle assembly. It reflects the "weakest link" in the entire suspension system, whether it be springs, axles, wheels, rims or tires.
- RIM** Rim Diameter x Width
- TIRE** Outside Diameter/ Width R Inside Diameter
- PRESSURE COLD** Cold tire inflation pressure in psi (US) / kPa and psi (Can.)
It is the practice of BWS to use maximum pressure for tire inflation.
- NSM** BWS has been assigned a registration number and has been authorized to use the NSM on their products. The NSM signifies conformance with the CMVSS set by Transport Canada.

TAG COMPLIANCE PLATE

0

MANUFACTURED BY / FABRIQUÉ PAR:  CENTREVILLE NEW-NOUVEAU BRUNSWICK CANADA			TYPE OF VEHICLE / TYPE DE VÉHICULE: TRA / REM						
			MODEL / MODÈLE: 0						
			GVWR / PNBV: 0 KG 0 LB						
			TARE: 0 KG 0 LB						
			DOM / DDF: 0 M/M 0 Y/A						
			VIN / NIV: 0						
GAWR / PNBE			RIM / JANTE		TIRE / PNEU			COLD INFLATED PRESSURE / PRESS. DE GONFLÉ À FROID	
POSITION	KG	LB	DIMENSION	DIMENSION	S/S	D/J	KPA	PSI / LPC	
FR/AV	0	0	0	0			0	0	
INT 1:									
INT 2:									
RR/AR									
THIS VEHICLE CONFORMS TO ALL APPLICABLE U.S. FMVSS AND CANADIAN CMVSS IN EFFECT ON THE DATE OF MANUFACTURE SHOWN ABOVE. CE VÉHICULE SE CONFORME A TOUS LES ÉTATS-UNIS APPLICABLES FMVSS ET CMVSS CANADIEN EN EFFET LA DATE DE LA FABRICATION MONTREE CI-DESSUS.									

HUB ALERT™

HEAT SENSING LABELS IDENTIFY POTENTIAL BRAKE, BEARING OR SEAL ISSUES BEFORE THEY CAUSE COSTLY REPAIRS!

THE NORMAL OPERATING
TEMPERATURE OF HUB/HUBCAP
GREASE OR OIL SHOULD NOT EXCEED
225°F (107°C).

- HUB ALERT™ will alert you to above normal wheel end operating temperature.
- HUB ALERT™ heat sensing label will turn **BLACK** when hub/hubcap surface temperature reaches 250°F (121°C).
- HUB ALERT™ indicates the need for a more detailed inspection of the overheating wheel end.
- New HUB ALERT™ label is applied to the hub/hubcap after resolving overheating issues.

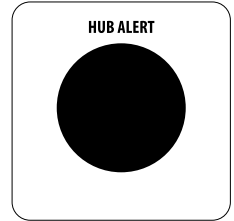
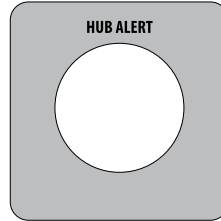

INTRODUCTION

Your new trailer has been carefully designed and built for easy, low maintenance, reliable operation that meets the diverse needs of the transportation industry. For safe, effective and trouble free operation of your trailer, each operator should read this manual to assure that your equipment continues to perform optimally.



Your Scissorneck or Rigidneck trailer are very versatile units. They are designed with a beavertail allowing for easy loading and unloading operations. All trailers come in tridem models and can have an optional booster or be axle ready. The neck on the Scissorneck can flatten out to load over and will give you a flat deck, allowing for longer cargo. It also comes equipped with two live rolls and two optional kicker rolls. Our trailers come equipped with parking brakes and sealed LED lighting systems, both in accordance with FMVSS/CMVSS regulations.

**READ THIS MANUAL COMPLETELY BEFORE
ATTEMPTING TO OPERATE THIS MACHINE.**



**DO NOT OPERATE THIS MACHINE IF ANY
PROTECTIVE GUARDS ARE MISSING
OR HAVE BEEN REMOVED.**

1.0 SAFETY PRECAUTIONS

SAFETY ALERT SYMBOL

This safety Alert symbol means:

**ATTENTION! BECOME ALERT!
YOUR SAFETY IS INVOLVED!**



The Safety Alert Symbol identifies important safety messages on the BWS trailer and in the manual. When you see the symbol, be alert to the possibility of personal injury or death. Follow the instructions in the safety message.

WARNING and CAUTION with the safety message. The appropriate signal word for each message has been selected using the following guidelines:

DAANGER

An immediate specific hazard which **WILL** result in severe personal injury or death if the proper precautions are not taken.

WARNING

A specific hazard or unsafe practice which **COULD** result in severe personal injury or death if proper precautions are **NOT TAKEN**.

CAUTION

Unsafe practices which **COULD** result in personal injury if proper precautions are **NOT TAKEN**, or as a reminder of good safety practices.

YOU are responsible for the **SAFE** operation and maintenance of your trailer. **YOU** must ensure that you and anyone else who is going to operate, maintain or work around the trailer be familiar with the operating and maintenance procedures and related **SAFETY** information contained in the operator's manual.

Remember, **YOU** are the key to safety. Good safety practices not only protect you but also the people around you. Make these practices a working part of your safety program. Be certain that **EVERYONE** operating this equipment is familiar with the recommended procedures and follows all safety precautions. Do not risk injury or death.

Remember the difference between being a driver and an efficient operator: Drivers may drive but an operator is a very safe, cost efficient and professional person.

Trailer owners must review operating instructions with operators or employees before allowing them to operate the equipment, and review at least annually thereafter.

The most important device on this equipment is a **SAFE** operator. It is the operator's responsibility to read and understand **ALL** Safety and Operating instructions in the manual and to follow them.

Any person who has not read and understood all operating and safety instructions is not qualified to operate the equipment.

Do not modify the equipment in any way. Unauthorized modification may impair the function and/or safety of the equipment and affect trailer life.

THINK SAFETY! WORK SAFELY!

1.0 OPERATING SAFETY

1. Read and understand the operator's manual and all safety signs before operating, maintaining or adjusting the BWS trailer.
2. Do not allow riders on any part of the trailer during road or highway travel.
3. Keep hands, feet, clothing and hair away from all moving parts.
4. Tie load before moving or transporting trailer.
5. Check tie-downs frequently during transport to prevent shifting or movement of the cargo.
6. Clear the area of all bystanders, especially children, before starting up and operating the truck, trailer or equipment.
7. Make sure that all lights and reflectors required by local highways and transport authorities are in place, clean and can be seen clearly by all overtaking and oncoming traffic.
8. Before disconnecting the tractor from the trailer unit(s) make sure that the tractor and trailer are on level ground and that the trailer park brakes are applied.

1.1 MAINTENANCE SAFETY

1. Read and understand all the information in the operator's manual regarding maintenance, adjustment and operation of any trailer or unit.
2. Stop the engine, remove ignition key and set the park brake before adjusting, servicing or maintaining any part of the trailer unit.

1.2 LOADING SAFETY

1. Do not drop load on trailer in order to prevent damaging the cargo or the trailer.
2. Place concentrated heavy loads over structural beams when loading.
3. Tie load securely before moving or transporting.
4. Check tie-downs frequently when transporting and keep them tight.
5. Do not exceed load concentration and total load carrying specifications for trailer.
6. Install lights or flags on load if it extends beyond deck.
7. Do not side load.

1.3 SAFETY DECAL MAINTENANCE

1. Keep safety decals and signs clean and legible at all times.
2. Replace safety decals and signs that are missing or have become illegible.
3. When ordering replacement parts that display a safety sign or decal, be sure to order the replacement safety sign or decal also.
4. Safety decals or signs are available from your Dealer Parts Department.

1.4 SIGN-OFF FORM

Anyone operating and/or maintaining a BWS trailer must read and clearly understand ALL safety, operating and maintenance information presented in this manual.

Do not operate or allow anyone else to operate this equipment until such information has been reviewed. Review this information annually.

Make these periodic reviews of SAFETY and OPERATION a standard practice for all of your equipment.

A sign-off sheet is provided for your record keeping to show that all personnel who will be operating or maintaining the equipment have read, and understood, the information in the operator's manual and have been instructed in the operation of the equipment.

2.0 SAFETY DECALS

The types of decals used on the equipment are shown below. Responsible practices require you to familiarize yourself with the various Safety Decals, the type of warning and the area, or particular function related to that area that requires your SAFETY AWARENESS.

THINK SAFETY! WORK SAFELY!

WARNING!

AIR SUSPENSION MUST BE DUMPED PRIOR TO LOADING AND UNLOADING. FAILURE TO DO SO MAY RESULT IN SERIOUS DAMAGE.

BWS Manufacturing Ltd. #100400

WARNING

DESIGN PERFORMANCE OF THE AIR SYSTEM REQUIRES A MINIMUM 115 TO 130 PSI UNINTERUPTED AIR PRESSURE TO THIS TRAILER

AVERTISSEMENT

LA CONCEPTION DE RENDEMENT DU SYSTÈME D'AIR NÉCESSITE QUE CETTE SEMI-REMORQUE SOIT ALIMENTÉE AVEC UNE PRESSION D'AIR ININTERROMPUE DE 115 A 130 LB/PO2

www.bwstrailers.com

DO NOT WELD, DRILL OR CUT HOLES IN MAIN FRAME RAILS

SERIOUS DAMAGE MAY OCCUR

www.bwstrailers.com

 **CAUTION**

THIS TRAILER IS NOT DESIGNED FOR POINT LOADS

 **CAUTION**

IF LANDING GEAR IS TOUCHING THE GROUND... USE LOW GEAR

RAISE TRAILER (left arrow) LOWER TRAILER (right arrow)

LOW GEAR IS IN

XL4-G300-01 OUTSIDE MOUNT

990301

 **RIDEWELL SUSPENSIONS**

MONOPIVOT 240 BOLT TORQUE MINIMUM SPECIFICATIONS

ECCENTRIC PIVOT BOLT	1,000 FT. LBS. (1350 N.M)
SHOCK BOLT	160 FT. LBS. (220 N.M)
AIR SPRING CONNECTION - 3/4"	50 FT. LBS. (70 N.M)
AIR SPRING CONNECTION - 1/2"	25 FT. LBS. (35 N.M)
BUSHING CLAMP BOLT	190 FT. LBS. (260 N.M)

See Service Manual for Details.

1990003

 **RIDEWELL SUSPENSIONS**

30,000 LB. CAPACITY OVERSLUNG/UNDERSLUNG

RAR-240 PSIG SCALE

ESTIMATED SPRING LOAD PER AXLE	AIR SPRING REQUIRED PSIG
30,000#	90
26,500#	80
20,000#	60
13,500#	40
7,000#	20

RIDEWELL CORP.
P.O. Box 4596, Springfield, MO 65808 USA
PH: 800-641-4122 (417) 833-4565
www.ridewellcorp.com

Estimated values are approximate and include 1,200# for complete axle assembly. Actual values must be verified by certified scales.



REMEMBER

If Safety Decals have been damaged, removed, become illegible or parts are replaced without decals, new decals must be applied. New decals are available from your authorized dealer.

3.0 OPERATING PROCEDURES

3.1 BREAK-IN/INSPECTION

Time and distance specify the normal break-in procedure for a trailer:

1. Check slack adjuster function for the first 3 weeks of operation.
2. Check hub oil levels daily for the first 3 weeks of operation.
3. Check tires for proper inflation pressures. Re-torque wheel nuts after 100 km.

3.1.1 500 MILE / 800 KM INSPECTION

After the first 500 miles/800km of service, some 'settling in' will have occurred, particularly in the suspension components.

AT THIS TIME:

1. Re-torque all bolts and fasteners paying particular attention to the axle U-bolts, hub studs, upper and lower fifth wheel bolts and the suspension system. Refer to values in the maintenance section when re-torquing.
2. Check tires for proper inflation pressures and rim alignment. Re-torque wheel nuts. Block the axle and spin the wheels. Check for brake drag and wheel bearing adjustment.
3. Check oil levels in hubs. Maintain proper oil level. If any levels are low, check for leaks and repair.
4. Check axle alignment. Refer to maintenance section for procedure.

3.1.2 10,000 MILE / 16,000 KM INSPECTION

1. Check the function and adjustment of the brakes on each axle. No shoes should drag on the drum when the brakes are not applied.
2. Check tire inflation pressures and tread wear. Always match tires with tread wear that is worn to 1/8" in difference. If unusual or excessive tire wear occurs, it indicates something is wrong. Check further to determine the cause and correct it. See tires section for further information.
3. Re-torque all bolts and bolted connections.
4. Visually check all welds and adjacent areas for cracks. Any cracks should be repaired as soon as possible by an BWS dealer.
5. Ensure all suspension hangers and related members are tight and secure.
6. Check axle alignment. Refer to maintenance section for procedure.

3.1.3 20,000 MILE / 32,000 KM INSPECTION

1. Check each brake lining for wear. Replace or adjust as required.
2. Check the axle alignment. Refer to maintenance section for procedure.
3. Check the wheel wobble. Adjust as required.
4. Check the axle alignment.
5. Replace gear oil lubricant in each hub.

3.2 PRE-OPERATION VEHICLE INSPECTION PROCEDURE

The safe and trouble-free use of our trailers require the operator to maintain the unit in good operating condition. To assist the operator, a pre-operation checklist is provided that should be followed each time before the trailer is used.

Item numbers in Figure 1 correspond to the following WALK AROUND SEQUENCE.

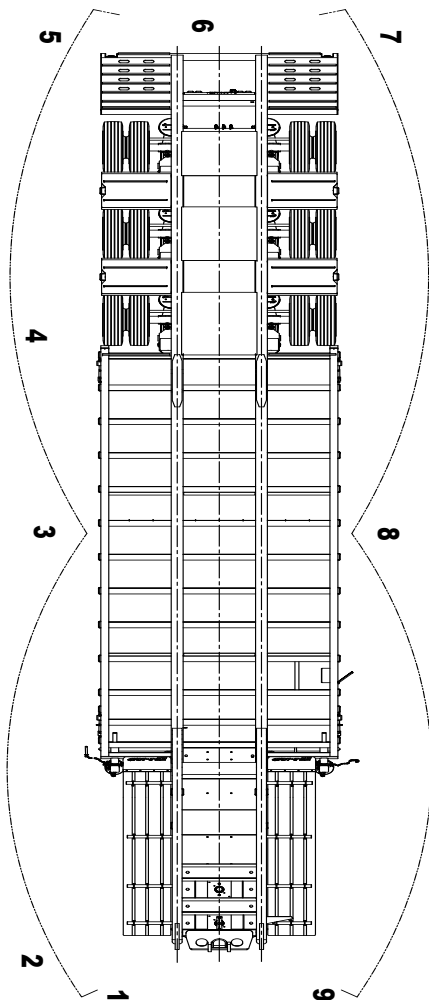

WALK AROUND SEQUENCE STEP 1 – TRAILER FRONTAL AREA

1. *Air and Electrical Connections*
 - a. Verify that glad hands are properly mounted, free of damage, not leaking and not worn.
 - b. Check electrical line receptacle: Ensure that it is properly mounted, free of damage and the plug is adequately seated with safety catch engaged to prevent accidental disconnection.
 - c. Ensure that air and electrical lines are properly secured against tangling, snagging and chafing with sufficient slack for turns.
2. *Lights & Reflectors*
 - a. Check that the front trailer clearance and identification lights are clean and operating.
 - b. Ensure reflectors are present and clean.

STEP 2 - FIFTH WHEEL COUPLING AREA

1. *King Pin (Trailer)*
 - a. Verify that glad hands are properly mounted, free of damage, not leaking and not worn.
2. *Air & Electrical Lines Visible From This Point*
 - a. Ensure lines are properly secured and are free from:
 - b. Tangling, snagging, and chaffing.

STEP 3 - RIGHT SIDE OF TRAILER AREA

1. *Front Trailer Support*
 - a. Verify that all four gooseneck pins are secured. (2 on each side)
 - b. Check air lines. Verify that there are no leaks in the system.
2. *Lights & Reflectors*
 - a. Ensure clearance lights are clean, operating and proper color.
 - b. Ensure reflectors are clean and proper color.

Figure 1 3. *Frame & Body*

- a. Ensure frame and cross members are not bent, cracked, or damaged.
4. *Placarding*
 - a. Ensure proper identification is used for the load being hauled.

NOTE!

The tractor items, part of North American Walk Around Sequence have been omitted.

RIGHT SIDE OF TRAILER AREA (CONTINUED)

STEP 4 - BRAKES

- a. Check condition of brake linings and drums.
- b. Check condition of hoses, lines & valves.
- c. Check slack adjusters.
- d. Check air chamber mounting.
- e. Check spring brakes.
- f. Drain moisture from air tank, close petcock. (If an air dryer is not supplied with the truck.)

STEP 5 - RIGHT REAR TRAILER WHEEL AREA

1. *Wheels/Axles*
 - a. Check condition of wheels and rims. Verify that there are – no cracked or bent rims, broken studs, or loose wheel nuts.
 - b. Condition of tires – Check for uneven tire wear.
 - c. Tires all same type, e.g. **DO NOT** mix radial and bias types on the same axle.
 - d. Wheel bearings and hub have no obvious leaking.
 - e. Check hub oil level.
 - f. Ensure mud flaps are in place and in good condition.
 - g. Ensure that air lines are not cracked, cut, crimped or otherwise damaged and secured against tangling, snagging or chafing.
2. *Suspension*
 - a. Check air bag inflation on the suspension system.
 - b. Axle alignment.
 - c. Check for loose or hanging equipment.



Figure 2

STEP 6 - REAR OF TRAILER

1. *Lights and Reflectors*
 - a. Rear clearance and identification lights – clean, operating and proper color.
 - b. Reflectors are clean and proper color.
 - c. Taillights - clean, operating and proper color.
2. *Cargo Securement*
 - a. Cargo properly loaded side to side and back to front.
 - b. Check cargo tie-downs and ensure they are tight.
 - c. Ensure concentrated load is positioned over structural beams.

STEP 7 - LEFT REAR TRAILER WHEEL AREA AND BRAKES

Check all items as done on right side (step 5).

STEP 8- LEFT SIDE OF TRAILER AREA

Check all items as done on right side (step 3).

STEP 9- TRAILER(S) FUNCTIONAL CHECK (TRACTOR ATTACHED)

1. Check for proper connection of air brake glad hands, and secure contact of electrical connection.
2. Start engine.
3. Build up air pressure in the tractor-trailer systems.
4. Turn on lights and inspect for proper function of:
 - a. Clearance lights.
 - b. Identification lights.
 - c. Turn signals and 4-way flashers.
 - d. Side marker lights.
 - e. Tail lights.
 - f. Stop lights.

5. Check the function of brakes.
 - a. Apply service brakes.
 - b. Apply parking brakes.
 - c. Apply accelerator with brakes in emergency to ensure park brake functions.
 - d. Stop engine.
 - i. Release trailer emergency brakes.
 - ii. Apply service brakes.

IMPORTANT!

Broken or malfunctioning equipment is dangerous and is to be replaced immediately.

AIR LOSS SHOULD NOT EXCEED:

3 psi per minute on single vehicles.

4 psi per minute on combination.

3.3 FIFTH WHEEL OPERATING INSTRUCTIONS

1. Failure to read, understand and follow the important information contained herein may result in a hazardous condition or cause a hazardous condition to develop.

2. Relative to the tractor trailer operations, there are other checks, inspections and procedures not listed here which are necessary, prudent and/or required by law. The following is in addition to these, and pertains to the fifth wheel only.

3. Perform these procedures with the area clear of obstacles and other personnel.



Figure 3

3.3.1 COUPLING PROCEDURE

1. Visually inspect the equipment before coupling.
 - a. Make sure the fifth wheel (Figure 3) is properly lubricated, the locks are open and the ramps are tilted down in the proper position.
 - b. Make sure the mounting of the fifth wheel to the tractor is in good condition and tight.

COUPLING PROCEDURE (CONTINUED)

2. Back up close to the trailer, centering the kingpin in the cradle of the fifth wheel, STOP.
3. Check to see that the trailer is at the proper height for coupling. The leading edge of the trailer plate should initially contact the fifth wheel top bearing surface behind its pivot axis as the tractor backs under the trailer. Raise or lower the deck supports as required to obtain this position.
4. Back under the trailer, keeping the trailer kingpin centered in the crotch of the fifth wheel.
5. After picking up the trailer with the fifth wheel, STOP, then continue backing until the fifth wheel locks firmly on the king pin.
6. Back up tight to the kingpin. Pull forward to test the completeness of the coupling as an initial check.
7. Visually check to see that the kingpin is in the fifth wheel locks, ensure that it is not overhanging the fifth wheel or caught in a grease groove. There should be no gap between the trailer plate and the fifth wheel.
8. Connect the light cord and the brake lines and be sure any slack in the lines is supported and the brake lines do not become tangled.
9. If your fifth wheel is equipped with a manual secondary lock, check to see that it is properly engaged.
10. Release air to the deck supports until they retract.
11. Hook air lines and light cord from tractor to trailer.



WARNING!

Attempting to couple the trailer at an improper height could result in a false or improper coupling and could cause damage to the fifth wheel or trailer.



WARNING!

A direct visual inspection is required to assure proper coupling. Several types of improper couplings will pass the initial pull test and the sound is unreliable. Do not take for granted it is properly coupled.



WARNING!

If you do not obtain a proper coupling, repeat this sequence. Do not use any fifth wheel which fails to operate properly.

3.3.2 UNCOUPLING PROCEDURE

1. Set the emergency brake on the tractor.
2. Set the trailer brakes with the tractor trailer protection switch.
3. Block the trailer wheels.
4. If the trailer is equipped with air ride suspension, air should be dumped from the air bags after the parking brake is applied and before landing gear is extended.
5. Crank down the landing gear until they touch the ground and give a few extra turns in low gear. Do not raise the trailer off the fifth wheel.
6. It may be necessary to provide a base for the landing gear in poor conditions if the trailers are loaded without the tractor attached.
7. Fold down or remove the crank handle and place it in the crank handle holder.
8. Disconnect the light cord and brake lines.
9. Unlock the fifth wheel, including the mandatory secondary lock if so equipped. Dump the suspension system if the truck is equipped with an air ride suspension.
10. Release the tractor emergency brake and pull out slowly from under the trailer. Let the trailer slide down the fifth wheel and pick up ramps with minimal impact of the trailer landing gear with the ground.

DECK SUPPORTS



Figure 4

3.4 LOADING

It is the responsibility of the operator to review and be familiar with the trailer loading capacity specifications and make sure that all loading limitations or restrictions are complied with for each operating jurisdiction. Exceeding the trailer weight specifications can result in damage to the structure. Exceeding the road restrictions is illegal.

- a. Do not drop a load on the trailer. Place it on the floor in a position of equalize load distribution.
- b. Determine the load carrying capacity of your trailer and the proper load position before you start loading.

3.4.1 TRAILER WEIGHT DISTRIBUTION

- 1. Trailers are designed for uniform load distribution as shown in Figure 5. The load should be distributed equally between the front and the rear of the trailer.
- 2. Crosswise weights should be equally distributed (Figure 6) . A heavy load should not be placed on one side. This will overload suspensions and tires on that side. Place load so that weight will be equal on rear tires, eliminating possible twisting of the frame and overloading of axle housings and wheel bearings.
- 3. Loading heavy concentrated loads not occupying full trailer floor area:
 - Do not place heavy concentrated loads on trailer edges.
 - Heavy concentrated loads must be placed on frame rails.

UNIFORM LOAD DISTRIBUTION FRONT TO BACK

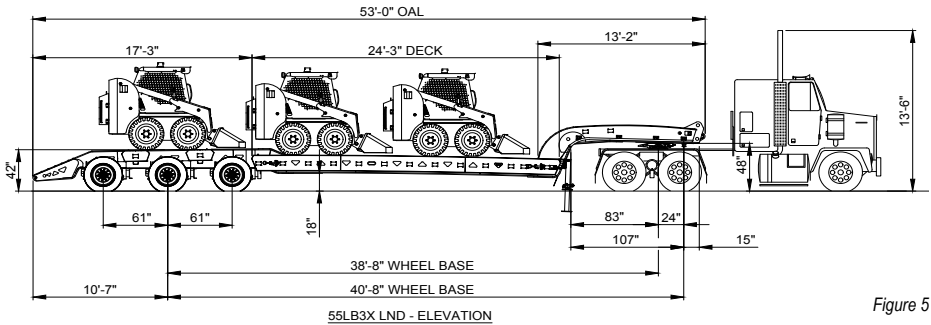

Figure 5

UNIFORM LOAD DISTRIBUTION SIDE TO SIDE

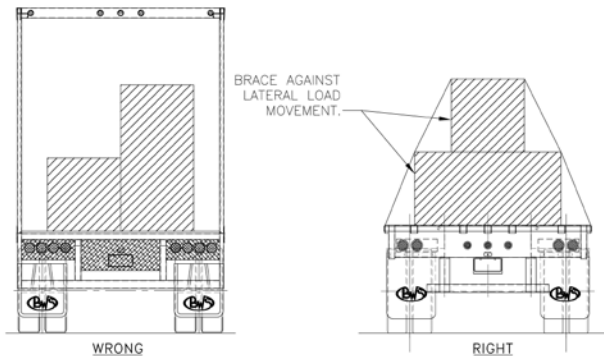

Figure 6

3.4.2 LOAD RESTRAINTS

All loads must be properly secured before moving or transporting the trailer to prevent cargo movement. Attach the load restraints in a crossing pattern to prevent both lateral and longitudinal movement. Do not exceed the working strength of the restraints or the anchor. Check the restraints frequently during transport to ensure they stay tight. If they remain loose, the load can shift or move and lead to an unsafe condition.

Some approved tie-downs include but are not limited to: (Figures 7A, and 7B)
See North American Securement Laws.

GENERAL OPERATING INSTRUCTIONS

1. Ensure the air lines are securely connected and have sufficient slack for turns.
2. Ensure the brakes are properly adjusted and functioning adequately.
3. Ensure the electrical harness is securely attached and all lights and reflectors are clean and in good working order.
4. Ensure that the mud flaps are in good condition to minimize road splash in wet conditions.
5. Always keep the trailer in good mechanical condition.
6. Ensure the cargo is securely tied down.



Figure 7A



Figure 7B

3.5 TRANSPORTING

After following the preceding instructions, your BWS trailer or unit is ready for transport. It is wise to review operating instructions periodically to refresh your memory. Good operation procedures result in a safe work environment for all.

1. Ensure the trailer is securely attached and locked into position.
2. Ensure the air lines are securely connected and have sufficient slack for turns.
3. Ensure the brakes are properly adjusted and functioning adequately.
4. Ensure the electrical harness is securely attached and all lights and reflectors are clean & in good working order.
5. Ensure that the mud flaps are in good condition to minimize road splash in wet conditions.
6. Always keep the trailer in good mechanical condition.
7. Ensure the cargo is securely tied down.

3.5.1 BRAKING GUIDELINES

Safe, reliable and trouble-free operation of your trailer requires that the brakes be maintained in good operating condition. The improper use of brakes by the driver can contribute to shorter brake component life, result in system malfunctions, and cause poor tire wear patterns. The following list summarizes some basic operational guidelines for the driver.

3.5.1 BRAKING GUIDELINES

1. Check the function of the brake system before starting a trip.
2. Maintain a safe speed at all times. Slow down for rough, slippery, congested, or winding road conditions.
3. Always provide sufficient vehicle spacing on the road to allow for safe stopping distance.
4. Apply brakes gradually to produce an even deceleration until the vehicle is stopped.
5. Watch traffic patterns ahead. Anticipate pattern changes that could result in an emergency. Apply the brakes gradually in sufficient time to produce a controlled stop.
6. Shift to a lower gear to use engine compression as the retarding force when going down steep grades.
7. Do not apply brakes for a long period of time such as when traveling on a long downgrade. Light intermittent brake application will result in proper vehicle control and keep brakes from overheating.
8. Dry the brakes by applying them several times after going through water.
9. Release the brakes just before going over railroad tracks or in other rough conditions. By allowing the wheels to turn over rough road surfaces, there will be no shock loads to the brake system components and the possibility of flat spotting tires will be reduced.
10. Wet, icy or snow-packed surfaces require special care. Make sure ABS is functioning properly.
11. Use wheel chocks, apply trailer and tractor parking brakes when parking the unit.
12. When trailer-parking brakes are applied with hot drums, it may result in a cracked drum. Allow drums to cool before applying the brakes.
13. Fanning, or repeated on-and-off applications, will use up the system air reserves. This procedure is not recommended with ABS. The wasting of air pressure reserves could result in insufficient air pressure should an emergency occur.
14. Hard or panic stops can overheat the linings and drums. Overheating will cause brake fade. Severe overheating and fade can result in the complete loss of braking capability. Overheating will also substantially reduce the expected life of brake components.

3.5.2 TIRES

When operating the trailer, it is the responsibility of the driver to check the tires frequently. Inflation pressures, wear patterns and matching are critical parameters that must be monitored. The following factors affect tire life:

1. INSPECTION FREQUENCY

Tires should always be checked before the start of a run, twice during the day or every 4 hours, whichever comes first. It is also good practice to check the tires at each rest period during the day. When a driver hears or feels unusual handling characteristics, the first items to check are the tires. Problems found early can help avoid more serious problems later on. A sample of typical abnormal wear patterns are shown in the maintenance section of the tire wear problem before proceeding.

2. INFLATION PRESSURE

Tires should always be operated at specified pressures. The tire is designed to run with the full width of the tread flat on the contact surface. Operating at other than specified pressures will change the tread contact patterns and dramatically shorten tire life. In addition, the tires will run hotter and can lead to blow-outs.

Check tire pressure when the tire is cold. A hot tire can read as much as 20 psi higher than a cold tire. If tires are over inflated, check for poor load distribution, uneven surface contact, over-loading or poor operating conditions. For inflation pressures, refer to manufacturers' specifications.

3. TIRE MATCHING

Do not mix radial and bias-ply tires on the same axle. Their operating characteristics are different and will lead to uneven tire loading, rapid tire wear and adverse handling characteristics. Matching also includes combining tires that have the same amount of tread remaining. A tire with more tread has a larger rolling radius and will have to carry a heavier load. The best performance will be obtained when the rolling radius is within 1/8" for all tires on the axle.

4.0 MAINTENANCE AND INSPECTION

The safe and efficient operation of your BWS trailer will depend a great deal on your diligence in following the maintenance and adjustment procedures outlined in this section. If you follow these recommendations your BWS trailer will work to its full potential. With adequate attention to regular and preventative maintenance your costs can be reduced significantly. The various components and systems of your BWS trailer, which will require daily and/or periodic inspections, maintenance and adjustments are presented in this section.

MAINTENANCE AND INSPECTION SUMMARY

Component	Frequency	Inspection
King Pin	30,000 mile/50,000 km or every 3 months	Kingpin wear and no damage to anchoring
Fifth wheel	30,000 mile/50,000 km or every 3 months	Hardware tight and kingpin lock clearance
Wheel Bearing	25,000 mile/40,000 km or every 3 months	Remove wheel for seal leaks, end play, bearing condition & cleanliness
Hub Oil	Daily	Check oil level
Oil Seals	Daily	Check for leaks & replace seals when leaks occur or wheel removed
Brakes	25,000 mile/40,000 km	Check lining wear. Check brake adjustments.
	1000,000 mile/150,000 km	Re-line as required
Wheels	Daily	Check for wobbles, cracked or bent rims and for loose, missing, broken stripped or otherwise ineffective fasteners.
Tires	Daily	Tire pressure Wear patterns
Axles	As required	Alignment to chassis
Suspension		
Air Ride Suspension	Daily, also see section 4.8	Air leakage Hardware tightness Mechanical Height check
Air System		
Relay Emergency Value	Every 3 to 6 months	Perform operating and leakage tests
Glad Hands	Daily	Check for cracks, worn or damaged components.
Spring Brake Value	Annually or 100,000 mile/150,000 km	Perform operating and leakage tests
Relay Value	Annually or 100,000 mile/150,000 km	Perform operating and leakage tests
Reservoir	Daily Every 6 months	Drain air tanks Integral check value function
Air Lines / Hoses	Daily	Check for leaks, chafing, kinking or other mechanical damage
Electrical System	Daily	Check for burned out bulbs and loose connections

4.1 KING PIN AND UPPER COUPLER

Inspect the kingpin and its structure on the trailer at regular intervals to be sure that they have not suffered damage or undue wear. The kingpin should not be bent.

The kingpin should be checked for excessive wear, looseness, chipped areas or cracks. Any kingpin bent or showing the above defects should be replaced or repaired at once.

Inspect the upper coupler assembly for any excessive bowing or cracks. Ensure the entire assembly is safely secured to the trailer by checking the condition of the welds, bolts or rivets, as used in the original construction.



WARNING!

Do not attempt to build up a worn kingpin by welding. The heat of the weld may weaken the special steel used to make the component. Work must be done by an authorized service technician only.

4.2 AXLES

4.2.1 SUGGESTED PREVENTATIVE MAINTENANCE SCHEDULE

- 18,000 Mile/30,000 km to 24,000 Mile/40,000 km
 - Check brake lining wear and re-line as required.
 - Check brake adjustments and inspect roller, roller shafts, anchor pins and bushings.
 - Inspect brake actuator, camshaft, camshaft bushings, camshaft brackets and camshaft bracket bushings for any wear. Lubricate brake actuating components.
- 60,000 Mile/100,000 km or at Time of Brake Reline
 - Overhaul and lubricate all brake actuating components.
 - Check all brake chambers.
 - Replace oil in wheel bearings.
- 100,000 Mile/150,000 km or minimum of twice a year
 - Inspect wheel bearings. Check all seals for signs of wear.
 - Re-torque suspension pivot bolts and torque rods U-bolts.

4.2.2 AXLE ALIGNMENT

Improper axle alignment with the vehicle frame or chassis will cause excessive tire wear and vehicle dog-tracking. Proper axle alignment is a vital part of your operation (maintenance) and should be checked on a regular basis.

Each BWS trailer is checked for correct alignment before it leaves the factory, but settlement of suspension may necessitate realignment after first 500 miles / 800 km.

The kingpin has a dead-center mark on the bottom side. To ensure proper alignment, a steel tape measure should be run from the center part of the kingpin to an identical location on either side of the front axle.

A small rigid hook in the shape of a question mark made of 1/4" bar stock will facilitate this alignment inspection. A steel tape can be attached to the end and this tool hooked over the kingpin. Figure 8 shows an example of a device used for alignment purposes.

PROCEDURE:

- Roll the vehicle back and forth over a level floor a few times to permit the connecting linkage to properly position itself and to center front and rear wheel track.
- Center the vehicle across its transverse and longitudinal sections.
- Measure the distances "C" and "D" (figure 9) from the
- Kingpin to forward axle. These distances must be within $1/8"$ (3.2 mm) of each other.
- Measure the distances "A" and "B" (figure 9) between the front and rear tandem axles.

These distances must be with in $1/8"$ (1.6 mm) of each other.



Figure 8

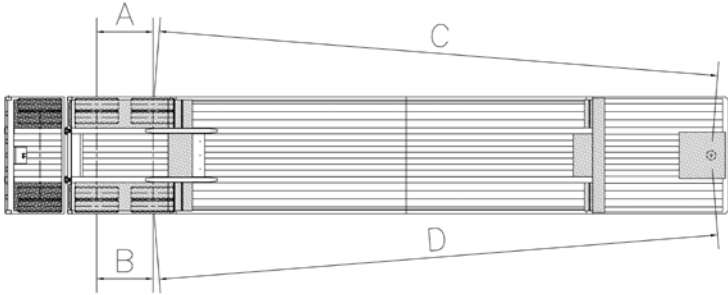

Figure 9

The small gauge in Figure 8 simplifies measuring the inner axle distances "A" and "B" in Figure 9. The gauge can be made of drill rod or pipe fittings. The material and details are not important as long as the parts are rigid and true. The pointer arms of the gauge should be parallel and held in the same plane.

If any of these measurements do not fall within the stated limit, the vehicle suspension should be thoroughly inspected for loose, worn or broken connecting and supporting parts. Adjustments in the suspension and the replacement of broken or worn parts should be made to bring the axles into alignment.

The limits of $1/16"$ and $1/8"$ appear very small in comparison to the overall dimensions of the vehicle, but they are recognized as the maximum permissible variation. The small size of these limits make it important that measurements be accurate. Failure to keep the axles properly aligned may cause tire scrub and suspension component strain.



IMPORTANT!

Replace and repair components as required.

4.2.3 WHEELS

Your trailer may be equipped with either steel or aluminum wheels. Check for damaged (bent) and loose wheels, studs, bolts and nuts regularly. The following procedure is to be used when mounting hub-piloted wheels (Disc Wheels) to an axle:



CAUTION!

Insufficient mounting torque can cause wheel shimmy, resulting in damage to parts and extreme tire wear. Excessive mounting torque can cause studs and cap nuts to break and discs to crack in stud hole area.



CAUTION!

Nuts must be kept tight by retorquing on a routine basis and by using the proper torque sequence. Loose nuts could result in loose wheel or premature wheel failure. This can result in an accident or injury.

WHEELS CONTINUED

1. Mount both wheels and snug up nuts in sequence shown (Figure 10A & 10B).
2. Torque in the sequence shown to proper torque level.
3. Recommended torque 450-500 ft.-lbs. (Torques are for clean dry threads.)
4. Check tires and wheels for proper seating and alignment.

The wheels should be retorqued after running for 50 to 100 miles, whenever they have been removed for maintenance, and when they leave the factory.

HUB PILOTED DISC WHEELS:

1. Known as motor or unimount wheels.
2. Have straight through bolt holes, no ball seats.
3. Center large hole of wheel onto pilot guides built on hub.
4. One nut per stud fastens wheels in place.
5. Clamped together with two piece flange nuts and spinning washers.
6. Right hand threads only for left and right sides of the trailer.

Figure 10A

Figure 10B

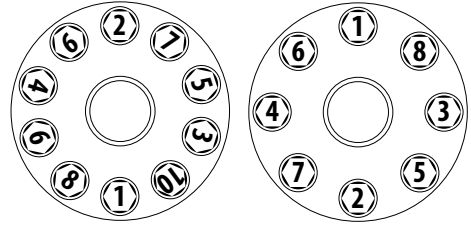

4.2.4 WHEEL HUBS

The main type of wheel being used on trailers in the commercial trucking industry today is as follows (figure 11):

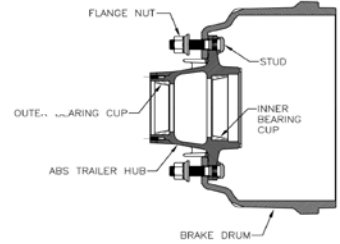

Figure 11

WHEEL BEARING / AXLE DIAGRAM (FIGURE 12)

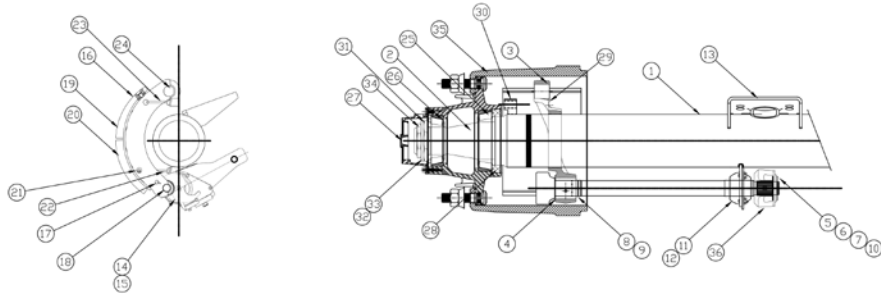

Figure 12

WHEEL BEARINGS PART BREAK DOWN

ITEM	DESCRIPTION	QTY
1	tube - 0.625 wall	2
2	spindle - 0.625 wall	2
3	spider	2
4	washer - 1 5/8" cam	2
5	washer - spline end	8
6	washer - spline end	2
7	washer - spline end	4
8	washer - 1 5/8" spider end	2
9	snap ring - spider end	2
10	snap ring - slack end	2
11	cam bracket - lh	1
12	cam bracket - rh	1
13	air chamber bracket	2
14	cam - lh	1
15	cam - rh	1
16	12.25 FC brake shoe	4
17	roller retainer	4
18	cam roller	4

ITEM	DESCRIPTION	QTY
19	CM 18 lining TMS R 23 GG	8
20	rivet	80
21	spring retainer	4
22	spring - return	2
23	spring - tension	4
24	anchor pin	4
25	bearing - inner	2
26	bearing outer	2
27	hub cap	2
28	seal	2
29	rubber grommet	2
30	abs block	2
31	spindle nut - inner	2
32	lock washer	2
33	star washer	2
34	spindle nut - outer	2
35	hub and drum	1
36	haldex auto slack	2

4.2.5 BEARING ADJUSTMENT PROCEDURE

TMC's Wheel End task force (The Maintenance Council task force on tractor-trailer communications) developed the following bearing adjustment recommendations. It represents the combined input of manufacturers of wheel end components.

STEP 1: BEARING LUBRICATION

Lubricate the wheel bearing with clean lubricant of the same type, as used in the axle sump or hub assembly.

STEP 2: INITIAL ADJUSTING NUT TORQUE ADJUSTMENT (WHILE ROTATING THE WHEEL)

Tighten the adjusting nut to a torque of 200 ft.lbs.

STEP 3: INITIAL BACK-OFF

Back the adjusting nut off one full turn.

STEP 4: FINAL ADJUSTING NUT TORQUE

Tighten the adjusting nut to a final torque of 100 ft.lbs while rotating the wheel.

BEARING ADJUSTMENT PROCEDURE CONTINUED

STEP 5: FINAL BACK-OFF

Back the adjusting nut off 1/8 to 1/4 turn (app. 0.003 inches)

NOTE: FOR SELF-LOCKING NUT SYSTEMS, CONSULT MANUFACTURERS' SPECIFICATIONS. BWS ASSUMES NO RESPONSIBILITY FOR BEARING WARRANTY.

Acceptable end play is .001"-.005" As measured with a dial indicator.

NOTE: LOOSE WHEEL BEARINGS ARE THE MAJOR CAUSE OF SEAL LEAKAGE. BE SURE BEARING TOLERANCE IS CORRECT.

4.2.6 BEARING ADJUSTMENT

Bearings must be correctly adjusted and properly lubricated to achieve maximum bearing life and to prevent damage to wheels, axles, and possibly the trailer. The bearings should be lubricated at regular intervals, depending on vehicle speeds, loads and general operating conditions. Changes of wheel bearing lubricants are recommended every 20,000 – 25,000 miles, or twice a year. (Spring & Fall).

Remove wheel assembly and bearing cones. Clean all old grease from hub of wheel bearings & hubcap with a good grade commercial cleaner and a stiff brush, not steel. DO NOT use gasoline or air hose in cleaning operation. Avoid spinning cone while cleaning. Allow the cleaned parts to dry and wipe them up with a clean, absorbent cloth or paper towel. Clean all tools used in the service operation.

NOTE: GREASE WILL NOT ADHERE TO A SURFACE THAT IS WET WITH SOLVENT BECAUSE THE SOLVENT MAY DILUTE THE LUBRICANT. CLEANLINESS IS MOST IMPORTANT. CONTAMINATION MAY DAMAGE THE BEARING COMPONENTS.

Inspect seals and seal spring surfaces, bearing cups and bearing cones for indications of wear or damage. Handle all parts carefully during inspection and packaging so the cage will not be bent or the rollers and cone damaged. Place bearing cones in cups and check for proper fit, and proper number.

GREASE LUBRICATED BEARINGS

Pack the bearings with a pressure packer, if possible, using an approved lubricant of medium consistency. If a pressure packer is not available, pack bearings by hand. You can do this by forcing the grease into the cavities, between the rollers and cage from the large end of the cone. Coat the hubcap with a light coat of grease.

OIL LUBRICATED BEARINGS

Use a gear type oil SAE-90 and spread a light coat of oil on all parts before assembly. To prevent 'hot' bearings and provide for maximum load carrying capacity, bearings should be kept free of slack and play. For positive close adjustment, a torque wrench should be used to tighten the bearing to the manufacturers' specifications.

NOTE: IT IS RECOMMENDED TO REPLACE AXLE SEALS EACH TIME WHEEL ENDS ARE SERVICED. THE FOLLOWING PROCEDURE WILL PROVIDE FOR SATISFACTORY BEARING ADJUSTMENT WHEN THE TORQUE METHOD IS NOT FEASIBLE. IT SHOULD BE NOTED THAT WHENEVER WHEELS, HUBS AND DRUMS ARE REMOVED FOR ANY PURPOSE, THE BEARINGS WILL REQUIRE RE-ADJUSTMENT.

With the wheel raised off the ground and the component parts on the spindle, the inner spindle nut should be tightened until there is no slack or play in the bearings. The inner nut should then be backed-off approximately one-half turn. The lock (thrust) washer is then placed in position. Next, the outer spindle nut is tightened against the washer. Once the procedure is completed, the bearings should be given a final check for any play. This condition can be corrected by progressive tightening of the inner nut, followed by a readjustment of the lock washer and outer nut.

BEARING ADJUSTMENT PROCEDURE CONTINUED

NOTE: THE SPINDLE NUT WRENCHES FOR THE VARIOUS AXLE MODELS CAN BE PURCHASED FROM OUR PARTS DEPARTMENT.

4.3 GREASE RETAINERS / OIL SEALS

4.3.1 RING AND SEAL TYPE (OIL) MAINTENANCE

Whenever the wheels must be removed for any reason, the seals should be inspected for nicks, etc. which could result in a leak.

4.3.2 RING AND SEAL TYPE (OIL) REPLACEMENT

1. Remove the seal from the hub by tapping on the face of the bearing cone. Care should be taken to avoid bending the cone cage or nicking the cone rollers.
2. If the axle ring is found to be defective, it can be removed by carefully and lightly tapping the ring all around with a ball peen hammer. Extreme care must be exercised to avoid cutting through the ring and damaging the spindle collar. After properly tapping the seal, it should expand so as to be removed by hand. Do not try to force the ring by hitting it from the axle bar side. There is no collar or lip on this side of the ring sufficient to prevent spindle damage.
3. To install the new ring and seal, it is mandatory that the seal manufacturers' recommended tool be used.
4. Prior to installing the new ring, the spindle should be clean and free from chips, burrs, etc.
5. Apply a thin coating of No. 2 sealer to the spindle axle ring collar.
6. Using the proper tool, install the ring on the spindle. (See manufacturers' recommendations for the proper position on the ring).
7. Apply No. 2 sealer to the seal's outer diameter.
8. Using the proper tool, press the seal into the hub until it is properly seated. (Proper seating specifications are available from the seal manufacturer).
9. Inspect the installation to assure that the seal components have bottomed evenly and are in the proper position.

RIDEWELL BOLT TORQUE SPECIFICATION CHART

Bolt Diameter (in.)	Lubricated Threads	
	Torque (Imp.)	Torque (SI)
1 1/2	1,100 ft.lbs.	1,490 N-m
1 1/4	1,000 ft.lbs.	1,350 N-m
1 1/8	500 ft.lbs.	680 N-m
1	360 ft.lbs.	490 N-m
1	460 ft.lbs.	625 N-m
7/8	350 ft.lbs.	475 N-m
3/4	160 ft.lbs.	220 N-m
3/4	190 ft.lbs.	260 N-m
5/8	100 ft.lbs.	135 N-m
3/4	50 ft.lbs.	70 N-m
1/2	25 ft.lbs.	35 N-m

Figure 13



RIDEWELL AIR RIDE TORQUE SPECIFICATION CHART

LOCATION	TORQUE (IMP.)	TORQUE (SI)
Eccentric Pivot Bolt	1,000 ft.lbs.	1,350 N-m
Shock Bolt	160 ft.lbs.	220 N-m
Air Spring Connection - 3/4"	50 ft.lbs.	70 N-m
Air Spring Connection - 1/2"	25 ft.lbs.	35 N-m
Bushing Clamp Bolt	190 ft.lbs.	260 N-m

Figure 14

4.4 SUSPENSION SYSTEM (AIR)

The axles are attached to and carried by the suspension system. BWS trailers use an air ride suspension system. Each must be kept tight and in good working order to obtain maximum performance and life. Following are suspension service and maintenance procedures to use.

4.4.1 INSPECTION

1. FREQUENCY

- During pre-delivery inspection.
- After first 500 miles / 800 km of operation.

2. ACTION

- Check that all fasteners are tightened to their specific torque. (Figures 13 & 14)
- Check for damaged or broken components.
- Check all suspension system and axle welds or cracks.
- Evaluate tire wear patterns. Use the wear patterns as a guide to determine if maintenance or adjustments are required on the suspension system.
- Check the alignment of the axles.
- Ensure air pressure is being maintained at a pressure greater than 65 p.s.i.



SUSPENSION SYSTEM

The axles are attached to and carried by the suspension system. BWS trailers use an air ride suspension system. Each must be kept tight and in good working order to obtain maximum performance and life. Following are suspension service and maintenance procedures to use.

1. FREQUENCY

- During pre-delivery inspection.
- After first 500 miles / 800 km of operation.
- Periodically.

2. ACTION

- Check that all fasteners are tightened to their specific torque.
- Check for damaged or broken components.
- Check all suspension system and axle welds or cracks.
- Evaluate tire wear patterns. Use the wear patterns as a guide to determine if maintenance or adjustments are required on the suspension system.
- Check the alignment of the axles.

4.5 AIR RIDE SUSPENSION (FIGURE 15)

4.5.1 PRE-OPERATION INSPECTION - BEFORE VEHICLE IS PUT IN SERVICE

- a. Inspect all welds at hanger to frame connections.
- b. Inspect for proper installation of cross member between hangers.
- c. Inspect axle alignment to kingpin.
- d. Check automatic air control valve and all line and fitting connections.
- e. Inspect air springs with 65 p.s.i. supply air or greater on a level surface for equal pressure and clearance.
- f. Inspect for proper mounting height.
- g. Inspect Pivot Bolts as per suspension manufactures specification.

1. DAILY INSPECTION

Visually inspect trailer to be sure it is level and that suspension ride height is correct. Check for loose or broken parts.

2. ROUTINE MAINTENANCE

- 30 days Check clearance around moving parts. Correct signs of interference.
 Check Axle, weld and bolt connections. Correct signs of security and wear.
- 60 days Check all welds.
 Check all pivot connections, suspension and shock.

AIR RIDE SUSPENSION ASSEMBLY

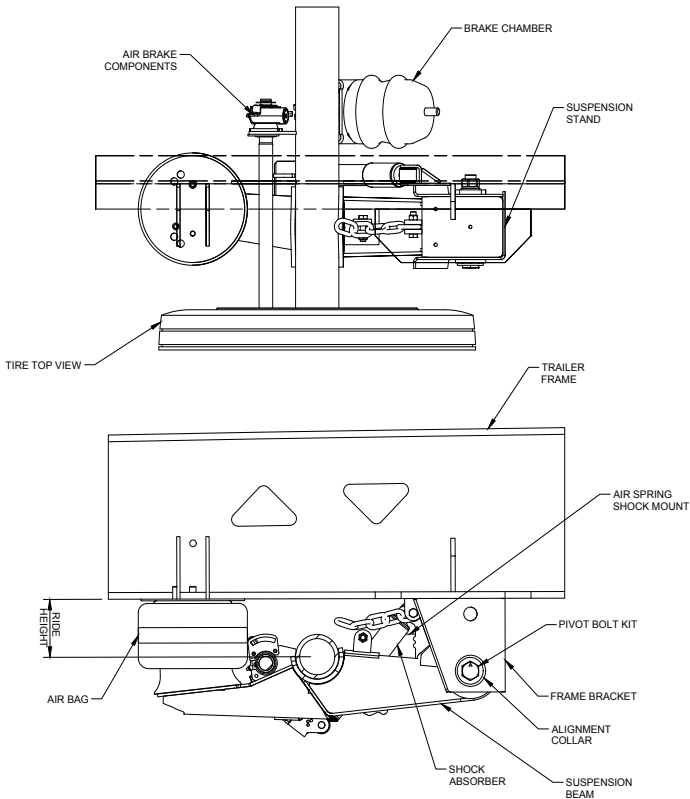

Figure 15

MAINTENANCE AIR SPRINGS

These seldom occur with the air springs unless they are rubbed, scuffed or punctured. If they fail, the chassis will settle down on the rubber bumper and you can drive to the next service depot for repairs. Identify and correct the cause of this problem before continuing.

4.5.2 AIR SPRING REPLACEMENT

- Exhaust air from system.
- Raise vehicle and support on safety stands.
- Remove air spring.
- Raise new air spring and tighten fasteners to their specified torque.

4.5.3 SHOCK ABSORBERS

Shock absorbers absorb vibration energy from the system and act as rebound stops for the suspension.

To replace shock absorber:

- Remove end fasteners.
- Install new shock absorbers using new mounting hardware.
- Tighten fasteners at their specified torque.

4.5.4 PIVOT BUSHING

The pivot bushing is a very durable, long lasting component.

Failures are rare and replacement should be undertaken only when all other potential problem causes have been eliminated. If replacement is required, obtain the removal/installation tool and replacement kit from your dealer.

4.5.5 PIVOT CONNECTION

The eccentric bolt at the pivot connection should have the anti-turn washer installed. Proper welding can not occur without the washer in place. Check for proper welding as per manufacturer's specifications.

4.5.6 AIR CONTROL SYSTEM

Air is supplied to the air springs by the air supply system from the tractor. A single height control valve on the axle monitors the chassis height .

4.5.7 HEIGHT CONTROL VALVE

This valve controls the adding or exhausting of air from the air springs. Air is added when the distance between the axle and chassis is decreased. Air is exhausted when the distance increases. A 5 to 15 second time delay is built into the valve to minimize jerking. Replace the valve if it does not function properly (Figure 16)

! CAUTION
Do not raise chassis unless shock absorbers are in place. Without shocks, the air spring will be over-extended and damaged.

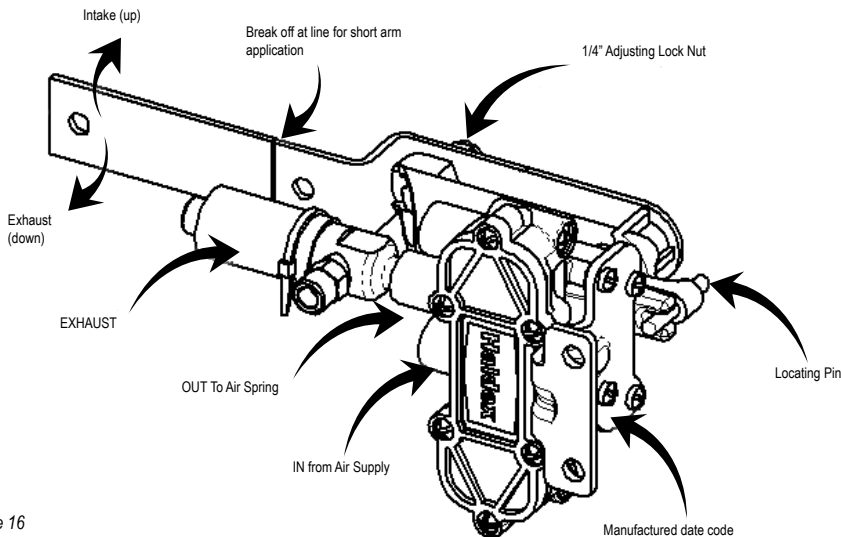

Figure 16

4.5.8 AIR DUMP VALVE WITH GAUGE



Figure 17

4.6 BRAKES

4.6.1 PREVENTATIVE MAINTENANCE

The operator, on the basis of past experience and severity of operation, should establish a schedule for the periodic cleaning, adjustment and inspection of brake equipment. Drum and linings are particularly subject to wear. The air brake system needs to be inspected, cleaned, lubricated and adjusted on a regular basis and each time the hubs are removed the deck supports.

1. BRAKE DRUMS

Inspect brake drums. Any accumulation of mud, dirt or rust on the drums should be removed. Any broken or cracked drums should be removed from service. Brake Drum manufacturers do not recommend re-boring of brake drums because of the reduced strength of refaced drums.

2. BRAKE LINING

Check and determine how much of the lining has been worn. Replace linings as required by current safety legislation.

4.6.2 BRAKE COMPONENT IDENTIFICATION

ITEM	PART NAME
1	retaining ring
2	camshaft adjusting washer
3	steel spacer
4	grease seal
5	camshaft bushing
6	grease fitting
7	bracket mounting bolt
8	lock washer
9	camshaft bracket
10	dust shield mounting bolt
11	lock washer
12	dust shield (half)
13	spider sub-assembly
14	anchor pin bushing

ITEM	PART NAME
15	anchor pin
16	steel spacer plate
17	camshaft
18	cam roller
19	shoe and lining assembly
20	return spring pin
21	show retainer spring
22	show return spring
23	lining
24	brake lining river
25	snap ring
26	washer
27	bronze bushing
28	brake roller spring

MAINTENANCE

1. BRAKE CHAMBERS

Your trailer is equipped with Haldex chambers. (Figure 19A & 19B). These chambers require no maintenance other than if they are leaking they must be replaced.



Figure 19A



Figure 19B

CAUTION: DO NOT ATTEMPT TO DISASSEMBLE

CAUTION: DO NOT ATTEMPT TO DISASSEMBLE

WARNING!

Do not attempt to repair or disassemble air brake chambers. A spring brake contains a very powerful compression spring. Incorrect handling may result in forceful release of the piggy back spring chamber and its contents which could cause death, severe personal injury and/or property damage.

2. AUTOMATIC SLACK ADJUSTERS

Trailers are equipped with automatic (self-adjusting) slack adjusters. A self-adjusting slack adjuster should never have to be manually adjusted while in service. The only time it should be adjusted is during installation or at re-line. By constantly manually adjusting, the internal clutch life can be shortened. Consult individual manufacturer for proper adjustment procedure. (Figure 20A & 20B)

4.6.4 SLACK ADJUSTER SCHEMATIC

Free Stroke = B minus A
Applied Stroke = C minus A

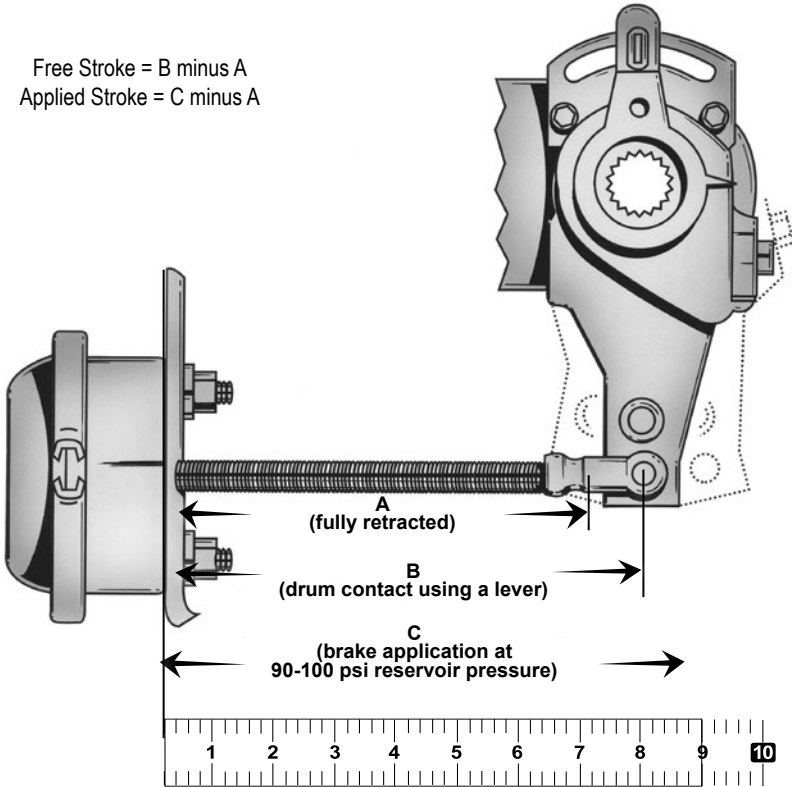

Figure 20A

4.6.5 HALDEX AUTO SLACK ADJUSTER

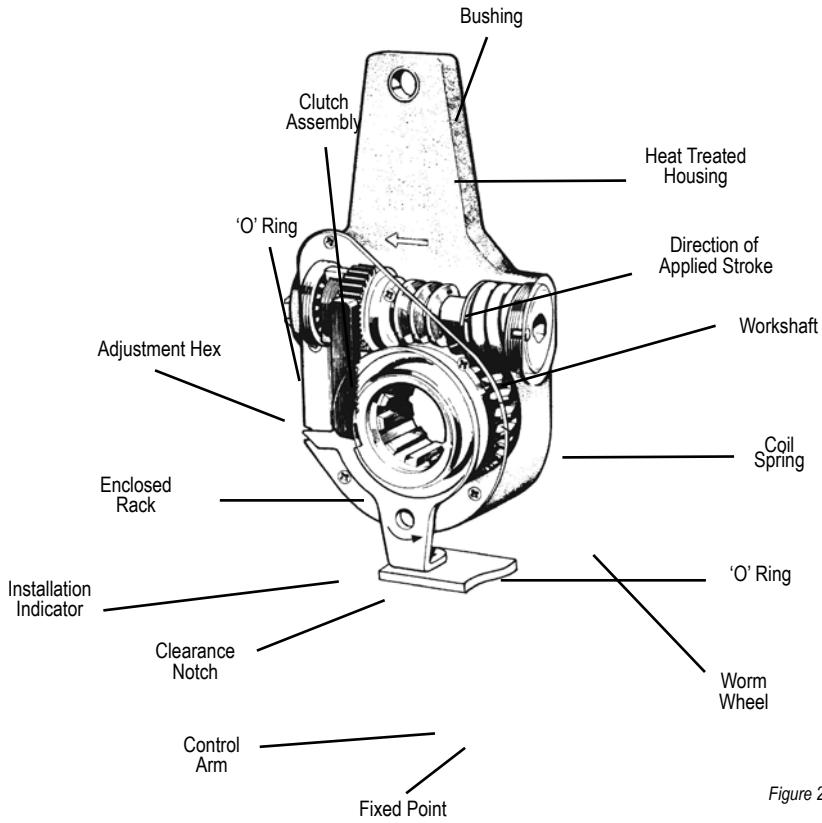

Figure 20B

TORQUE SPECIFICATIONS

Subject fasteners must be torqued to the following specifications.

ITEM	TORQUE	
	(ft.lbs)	(N.m)
1. Wheels		
Spoke wheels		
5/8" wheel nuts	160-200	215-270
3/4" wheel nuts	190-210	255-285
Stud-piloted wheels		
Inner nut (3/4 x 16)	450-500	610-680
Outer nut (1-1/8 x 16)	450-500	610-680
Hub-piloted wheels		
8 Stud	450-500	610-680
10 Stud	450-500	610-680
2. Wheel bearing nuts		
Torque inner nut while rotating wheel clockwise	200	270
Back off inner nut and retorque	100	135
Back off inner nut 1/8 to 1/4 turn (app. 0.003").		
Install perforated washer		
Torque outer nut	250-300	340-410
3. Spring brake chamber mounting nuts	80-120	110-160
4. Hub cap screws	15-20	20-30

4.7 TIRES

4.7.1 TIRE CARE AND MAINTENANCE

Although seemingly not requiring instruction, it has been established that through neglect, tires wear fast or fail early, even with the best of maintenance and service that tires deliver.

4.7.2 TIRE INSPECTION

A regular inspection of the tires is the first step in increasing tire mileage. These inspections will help to identify troubles, such as under-inflation, over-inflation and improper alignment. Minor damages, that may be repaired, can be detected during these inspections and save a tire that would otherwise fail.

Inflate tires to manufacturers recommended pressures. Proper inflation costs nothing, but will increase tire mileage. Under inflation causes abnormal wear at the sides of the tread because the outer edges of the tire carry the load, while the center tends to flex up away from the road. This causes the tire to run hotter.

Tires found to be under-inflated before operation should be returned to the proper pressure. Over-inflation causes abnormal wear at the center of the tread, also shortening the life of the tire. This is caused because the center of the tire tread carries more than its share of the load. Check for correct pressure when tires are cool. When a tire is in use and becomes heated, the air in the tire expands and the air pressure increases. Normal pressure build up is 20 pounds or less. Never bleed the tire to relieve built up pressure. If excessive build up of pressure occurs, load distribution, under inflation, speed or any combination of these is responsible. Over-inflation reduces the ability of the tire to absorb ordinary shock and causes fabric or tread separation, or both, resulting in tire failures. It will not compensate for overloading. An overinflated tire is more vulnerable to snags, cuts and punctures.

4.7.3 MECHANICAL IRREGULARITIES

Mechanical irregularities that will cause excessive wear include a sprung or sagging axle, which will cause the inside dual tire to carry a greater load. Brakes that are out of adjustment, or out-of-round brake drums will contribute to rapid and spotty tire wear. Improper brake adjustments will lead to spotty tire wear in several places, while out-of-round drums usually wear in a single spot. Improperly adjusted or worn wheel bearings can lead to uneven tire wear. Also improper axle alignment and worn torque rods will cause excessive tire wear.

4.7.4 RADIAL TIRE APPLICATION

Radial and bias-ply tires should never be mixed either in dual combination or on the same axle except in an emergency situation. Mixing on the same dual combination will result in uneven wear because of different flexing characteristics.

4.7.5 MATCHING TIRES TO RIMS

When mounting tires on rims, be sure the right tires are used on the right rims. Many tire failures can be traced to not having matched the tires properly. In most cases there is a preferred and an alternate rim for the popular tire sizes. The preferred widths are recommended as they provide the optimum rim for the tire ratio. Refer to manufacturer's recommendations.

The tires of each wheel must be matched to within 1/8" of the same rolling radius (3/4" of the same rolling circumference) under normal loading conditions. The tires should have equal pressures.

4.7.6 TIRE WEAR PATTERNS

OVER-INFLATION:

Excessive wear at the center of the tire indicates the air pressure in the tire is consistently too high. The tire is riding on the center tread and wearing it prematurely. Occasionally, this wear pattern can result from extremely wide tires on narrow rims. To correct, replace either the tires or the wheels.

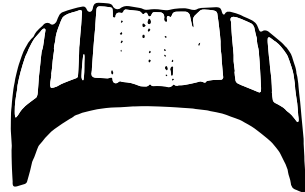

Figure 21

UNDER-INFLATION:

This type of wear usually results from consistent under-inflation. When a tire is under-inflated, there is too much contact with the road by the outer treads, which wear prematurely. When this type of wear occurs and the tire pressure is known to be consistently correct, the need for axle alignment could be indicated.

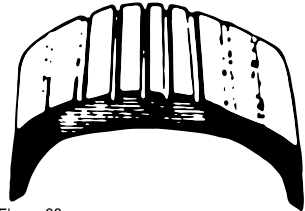

Figure 22

FEATHERING:

Feathering is a condition when the edge of each tread rib develops a slightly rounded edge on one side and a sharp edge on the other. By running your hand over the tire, you can usually feel the sharper edges before you will be able to see them. The most common causes of feathering are an incorrect toe-in setting, deteriorated bushing in the suspension or misalignment.

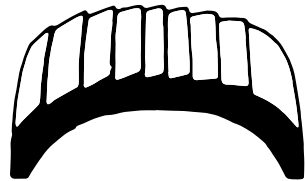

Figure 23

ONE SIDE WEAR:

When an inner or outer rib wears faster than the rest of the tire, the need for axle alignment is indicated. Misalignment could also be due to sagging springs or worn suspension system components.

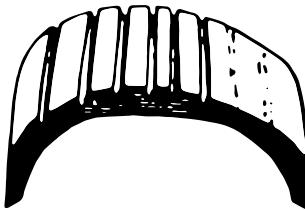

Figure 24

CUPPING:

Cups or scalloped dips appearing around the edge of the tread almost always indicate worn (sometimes bent) suspension parts. Adjustments of axle alignment alone will seldom cure the problem. Any worn component that connects the wheel to the suspension can cause this type of wear. Occasionally, wheels that are out of balance will wear like this, but wheel imbalance usually shows up as bald spots between the outside edges and centre of the tread.

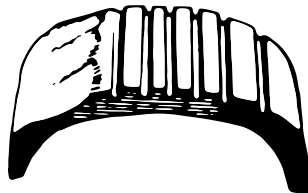

Figure 25

SECOND RIB WEAR:

Second rib wear is usually found only in radial tires, and appears where the steel belts end in relation to the tread. It can be kept to a minimum by careful attention to tire pressure and frequently rotating the tires. This is often considered normal wear but excessive amounts indicate that the tires are too wide for the wheels.

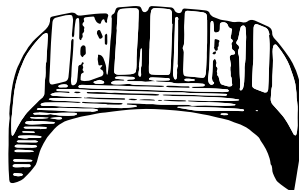

Figure 26

4.8 AIR SYSTEM COMPONENTS

Pressurized air is supplied to the system by the tractor and provides power to release and operate service and parking brakes. A variety of valves can be at various locations in the system and valves must be inspected and functionally checked on a regular basis to insure proper operation.

4.8.1 GLAD HANDS

During the pre-trip inspection, the driver should inspect the glad hands. Check for worn or damaged parts. Replace or repair as required.

GLAD HANDS - FRONT

Figure 27



4.8.2 ABS

Our trailers incorporate a Haldex ABS system when required. BWS reserves the right to change suppliers at any time. The following web sites contain valuable information including downloadable copies of ABS service and maintenance manuals.

Haldex

<https://www.haldex.com/globalassets/north-america/documents/abs/L30041.pdf>



IMPORTANT!

The air system works best when clean, dry air is supplied from the tractor. Equipping the system with a dryer and a filter pays dividends by reducing maintenance requirements.

4.9 ELECTRICAL SYSTEM

The electrical system features a weatherproof cab tie. The lighting system incorporates Grote Ultra Blue LED lighting. It is important that all systems are checked each day or before every trip, and that lenses and reflective identification devices are kept clean. The operator should periodically, during night operation, check for lights flickering or momentary outages. This often indicates loose connections, light diode problems.

TAIL LIGHTS



Figure 28

FRONT MARKER LIGHTS



Figure 29

MIDWAY TURN SIGNALS



Figure 30

ELECTRICAL DECAL

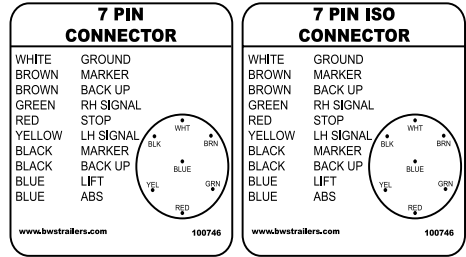

MAINTENANCE SAFETY

- Always block vehicle wheels. Stop engine when working under a vehicle. Depleting vehicle air system pressure may cause a vehicle to roll. Keep hands away from chamber push rods and slack adjusters; they may automatically apply as system pressure drops.
- Never connect or disconnect a hose or line containing air pressure. It may whip as air escapes. Never remove a component or pipe plug unless you are certain all system pressure has been depleted.
- Never exceed recommended air pressure and always wear safety glasses when working with air pressure. Never look into air jets or direct them at anyone.
- Never attempt to disassemble a component until you have read and understood recommended procedures. Some components contain powerful springs and injury can result if not properly disassembled. Use only proper tools and observe all precautions pertaining to use of those tools.
- Use original manufacturer replacement parts and components.
 - Only components, devices, mounting and attaching hardware specifically designed should be used.
 - Replacement hardware, tubing, hose fittings, etc. should be the equivalent size, type, length and strength as the original equipment.
 - Make certain that when replacing tubing or hose, all supports, clamps or suspending devices that were originally installed by the vehicle manufacturer are reinstalled.
 - Devices with stripped threads or damaged parts should be replaced. Repairs requiring machining should not be attempted.

5.0 SCISSORNECK OPERATION

40SN3X

CHANGE FROM GOOSENECK TRAILER TO FLATBED:

Activate parking brakes on truck and trailer. Connect winch cable to front of trailer and secure hook in eye plate. Adjust winch so there is light tension on the gooseneck. Disconnect trailer air and electrical lines. Place lines in gooseneck cavity so they will not be damaged during subsequent operations. Remove gooseneck pins on either side of trailer (Figure 32).

Release fifth wheel pin lock. Pull truck ahead slowly while releasing the winch line so that the trailer will disconnect from the fifth wheel and move over truck live roll in a controlled manner. As the truck moves ahead the trailer will straighten out in the flatbed position.

Lower trailer to the ground with the winch while driving ahead far enough to allow it to flatten completely out (Figure 33).

At this point if you have a deck load for the trailer that is going to load over the gooseneck you can move the truck out of the way and complete the loading and securing of the cargo.

Reinstall the gooseneck pins in the flatbed position and secure with safety pins.

Ensure that the winch cable is securely connected to the trailer before attempting to reconnect the trailer to the truck. Operate the winch to raise the front of the trailer over the live roll on the truck and connect it securely to the truck fifth wheel.

Connect the trailer air and electrical lines to the truck.

CHANGE FROM FLATBED TRAILER TO GOOSENECK TRAILER:

Reverse procedure detailed above.



Figure 31



Figure 32



Figure 33

6.0 SINGLE AXLE BOOSTER OPERATING INSTRUCTIONS

11SB1X

Park Single Axle Booster on a solid level surface that is a safe distance from any traffic or personnel. Level ground is required for verifying height and allowing correct connection process. Chock Booster wheels so that it can not make any uncontrolled movement during the connection process.

VERIFY VALVES ARE IN THE FOLLOWING POSITION (FIGURE 34):

- A: Suspension Control: Over Ride
- B: Axle Lock: Unlock
- C: Suspension Over Ride: Hold-Transport



Figure 34

Reverse trailer into a position that lines up with the booster stopping approximately ten (10) feet from the unit. Exit the truck and verify that the booster is positioned in the center of the trailer. Verify that the booster line up pin is installed in trailer. (Figure 35)

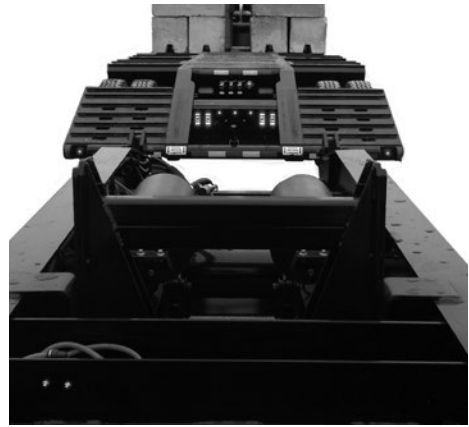

Figure 35

Ensure that the front support feet are connected in a position that will allow the booster to operate correctly after the air from the trailer suspension bags is allowed to flow to the booster ride bags. If the operator has not used the booster on this trailer (in this load configuration), refer to the sample photo for a first pin location.

Reverse the trailer against the booster and stop as soon as the booster unit mouth makes contact with the rear bumper. Set the parking brakes on the truck and the trailer. (Figure 36)

If required, pull ahead and back into the booster again until contact is made. (Figure 37)



Figure 36

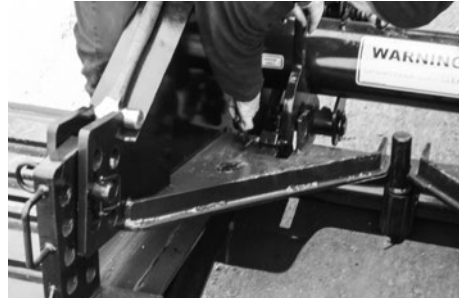

Figure 37

SINGLE AXLE BOOSTER OPERATING INSTRUCTIONS

During reversing process, confirm that the booster parking brakes are operating correctly. If the booster wheels rotate, stop the connection process and repair parking brakes.

Figure 38



Lower booster safety hooks into position to lock the booster in place on the rear of the trailer. Ensure that you are in a safe location at all times to avoid injury due to any unintended movement. If you are able to install safety pins at this time, then do so. If not, move onto the next step. (Figure 38)

Figure 39

Connect trailer air hoses for the Service and Air Bag lines only at this time. Leave the Emergency line disconnected to ensure Booster parking brakes will remain engaged. Open air valves of trailer for these lines only. Allow time for booster air tanks to fill with air supplied by the truck. (Figure 39)



Figure 40

Incorrect chain position can cause ride bag failure and/or injury.

Verify that booster suspension check chains are in extended operating position. Failure to position the check chains in the correct location will inhibit the correct operation of the unit. (Figure 40)



Figure 41

Operate the suspension over ride valve slowly to the raise position to inflate the booster ride bags. This will cause the booster to lift and force the support feet against the trailer beavertail. Operate this valve in the raise and lower position to move the booster and allow you to complete installing the safety lock pins. (Figure 41)



SINGLE AXLE BOOSTER OPERATING INSTRUCTIONS

If this is the first time you have installed the booster on this trailer and the safety lock arms will not engage enough to insert the safety lock pins, you can grind a small amount off the back of the arms to allow the pins to be inserted. If this does not work, contact your dealer for instructions before going any further. Only after the safety lock pins have been completely installed can you move onto the next step. Install support feet lock brackets. (Figure 42)



Figure 42

When this step is complete move the Suspension Over Ride Valve to the Hold Position.

Connect booster emergency air line to trailer and open valve. Connect booster electrical line to trailer.

Move suspension control valve to transport position (Figure 43). Allow time for air from trailer suspension bags to equalize with booster air bags (A). In order to ensure that the booster axle will have an adequate range of travel the ride height decal should be within +/- 1.5" of the booster side frame. (Figure 44) If the unit is within this range, the booster should be ready to operate. If not, move to the next step.

Depending on the load on the trailer you may need to reduce the load on the booster by temporarily moving the suspension control valve to the over ride position and moving the suspension over ride valve (A) to the lower position while reading the booster suspension gauge (C) to achieve the desired pressure.(Figure 43)

Return all valves to the transport position before operating the unit on any road.

If the ride height decal is above the frame, the front foot support needs to be moved upwards. If the Ride height decal is below the frame the front foot support needs to be moved downward. When the direction has been determined, move the suspension control valve to the over ride position (A).

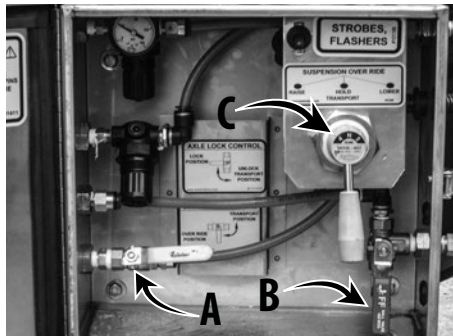

Figure 43

Move the suspension over ride valve (C) to the lower position and allow air to dump from the Booster ride air bags. This should allow the support feet to loosen and you will be able to adjust in the correct direction. Return the suspension over ride valve to the hold position and move the suspension over ride valve to the transport position.

Allow time for air from trailer suspension bags to equalize with the booster air bags. Review ride height decal for correct location and repeat this step if required. Verify that the trailer suspension gauge and booster suspension gauge read the same values to ensure that the air system is operating correctly.



Figure 44

Ensure that booster lights and brakes are operating correctly before moving the unit. Remove wheel chocks from tire location. The unit will automatically steer in the forward direction up to 20 degrees in either direction. Axle lock valve may be used while reversing the unit for short distances. This can be done by moving axle lock valve to the lock position during the process.

SINGLE AXLE BOOSTER OPERATING INSTRUCTIONS

DISCONNECTING BOOSTER FROM TRAILER:

Park trailer and booster on a solid level surface that is a safe distance from any traffic or people. Set parking brakes on truck, trailer and booster.

Ensure that load on trailer can be safely carried by trailer suspension alone before disconnecting booster.

Close the trailer booster connection valves and remove the air hoses and electrical line. Store lines in a safe position on booster to avoid damage during disconnection or eventual re-connection.

Verify that the booster parking brakes are engaged. Check booster wheels so that it can not make any uncontrolled movement during disconnection process.

Remove safety lock pins. You may need to reduce the load on the booster safety hooks by moving the suspension control valve to the over ride position and the suspension over ride valve to the lower position. Slowly reduce the load on the booster and at some point the safety hooks will loosen and you will be able to raise them. Reinstall the lock pins with the hooks in the upper position. (Figure 45)

Disconnect the front feet safety latches (Figure 46).

Slowly move the trailer forward and allow the booster to slide down the beavertail. Ensure that there are no personnel or equipment in a position to be injured by the booster as it moves to the ground (Figure 47).



Figure 45

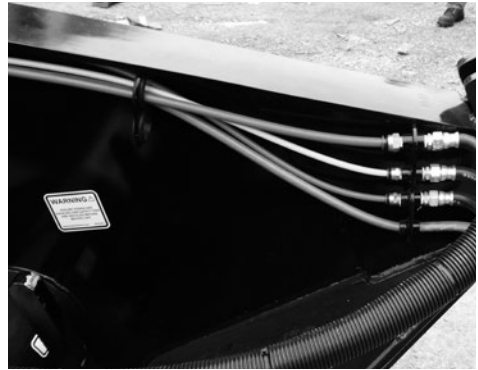

Figure 46



Figure 47



PLAN

703 [58'-7"] (OAL INCLUDING FLIP)

636 [53'-0"] (OAL INCLUDING P/U THROAT)

478 [39'-10"]

269 [22'-5"] (DECK)

156 [13'-2"]

AIR

SCHEMATICS

ELEVATION

MODEL: 55LB3X LND

5 TON TRIDEM SHORT - 6" DROP LOWBED

NOTE: ALL DIMENSIONS ARE LOADED & NOMINAL

NOTE: ALL DIMENSIONS ARE LOADED AND NOMINAL

BOOSTER

11SB1X

REV.3, PS1A2 - 11SB1X

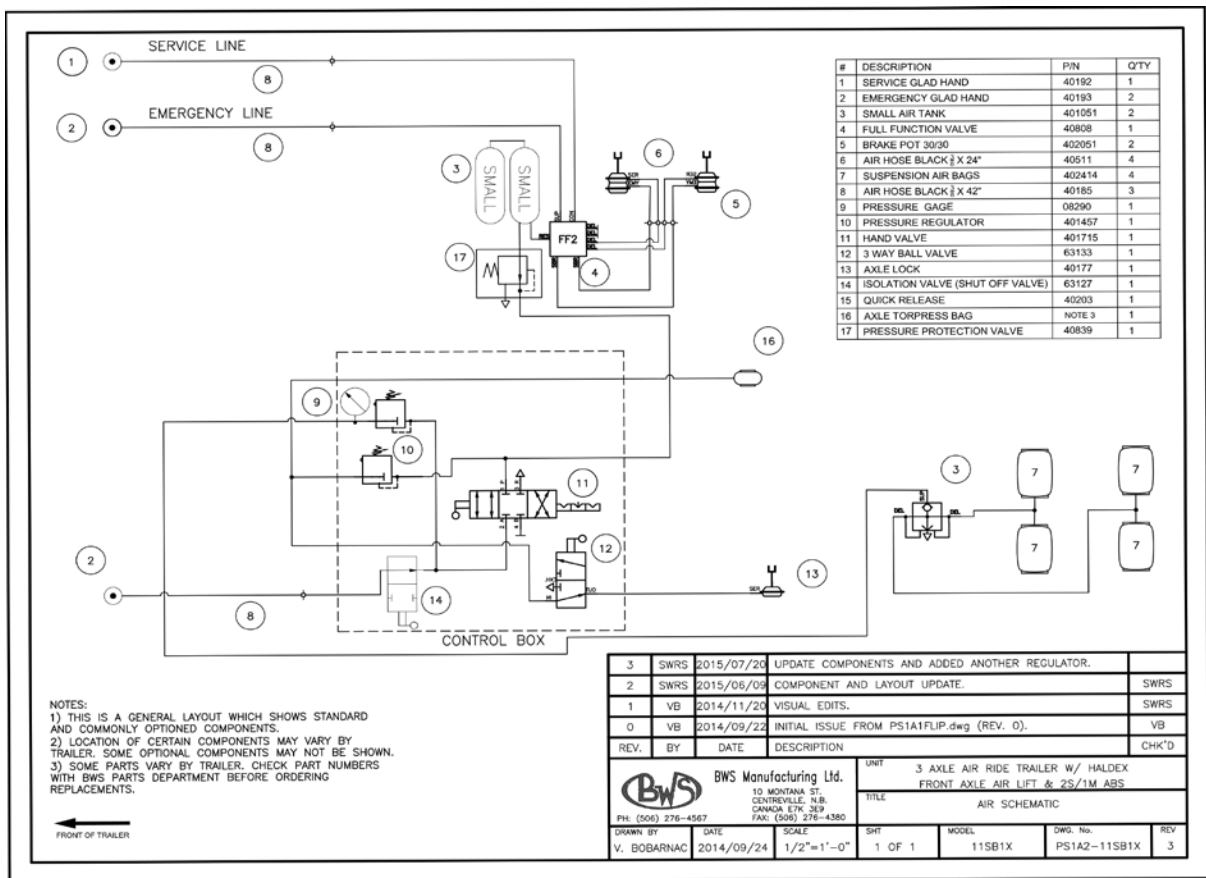

SCISSORNECK

3 Axle Air Ride with Haldex

Rev. 2, PS3A212X3-HAL

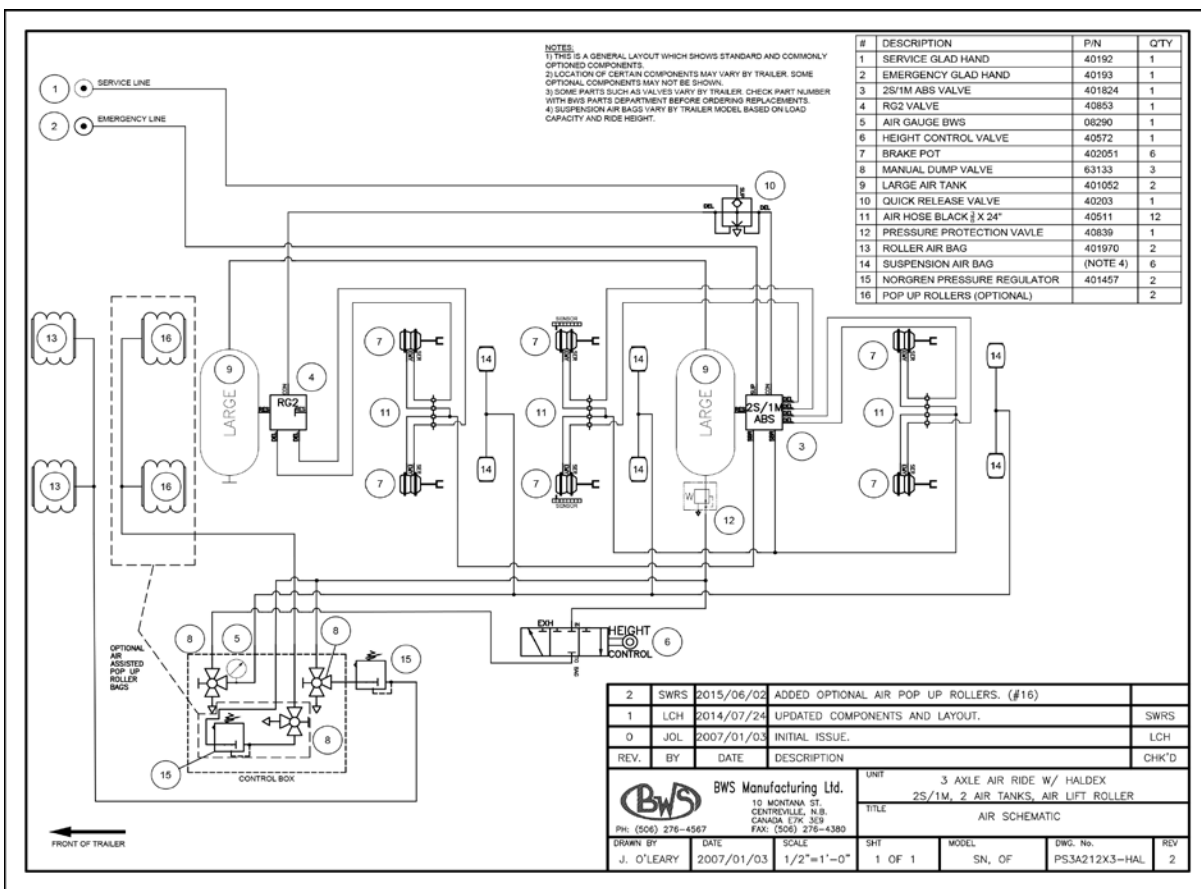

RIGIDNECK

3 Axle Air Ride with Haldex
Rev. 3, PS3A212-HAL

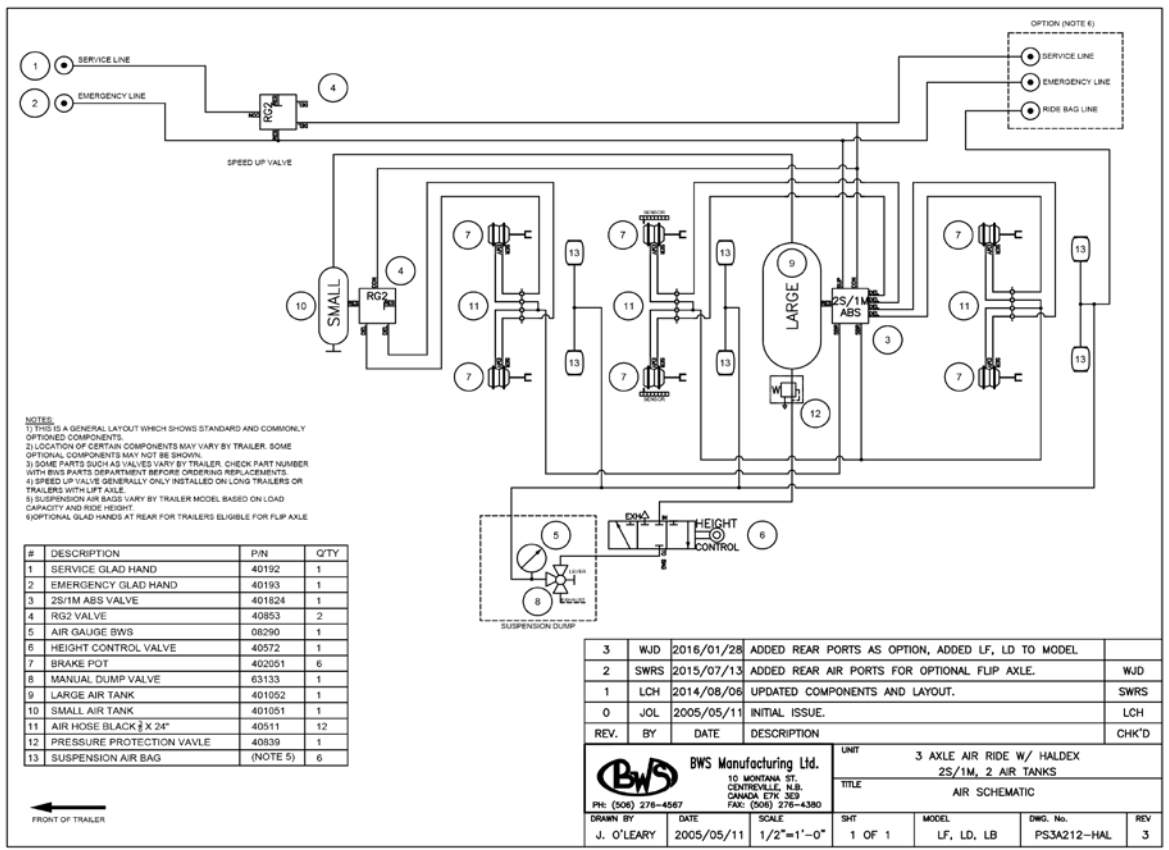

OILFIELD FLOAT

3 Axle Air Ride with Haldex
Rev. 2, PS3A3A212X3-HAL

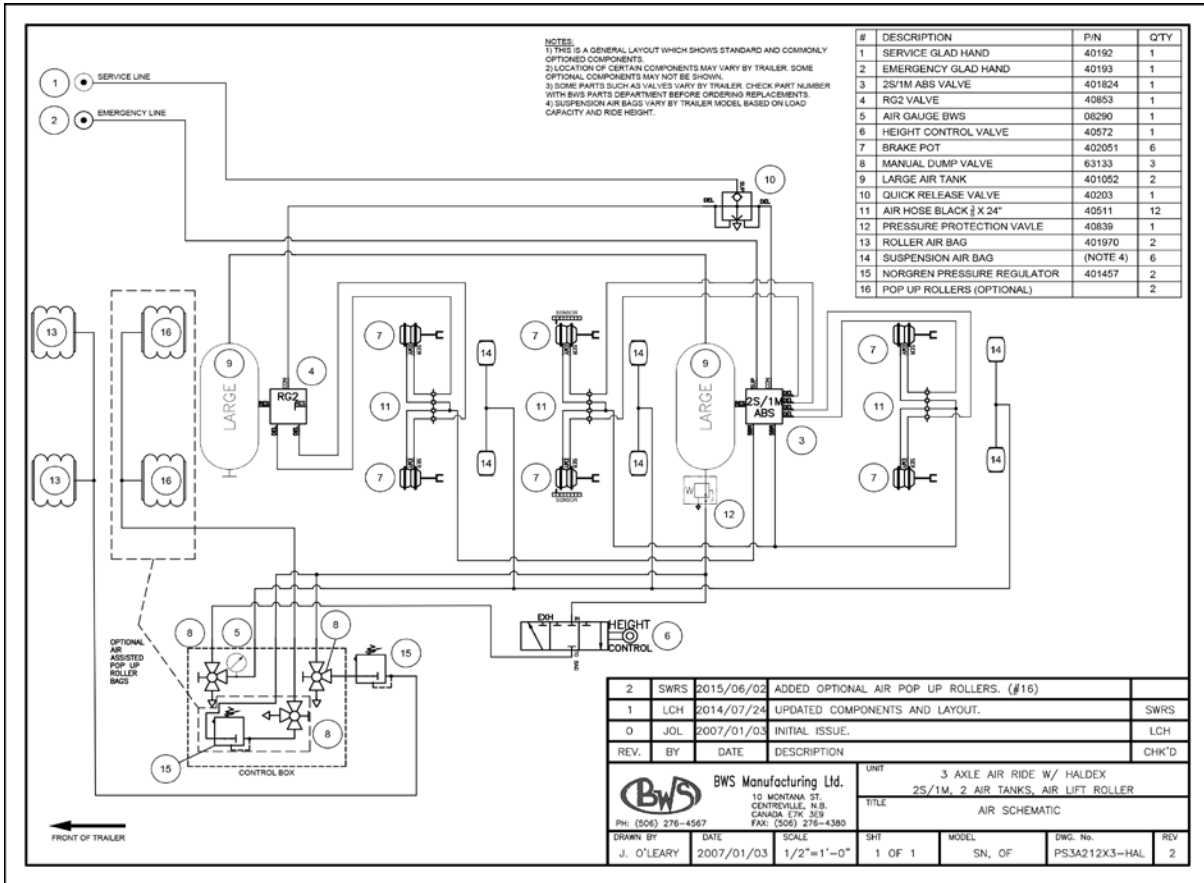

2	SWRS	2015/06/02	ADDED OPTIONAL AIR POP UP ROLLERS. (#16)	
1	LCH	2014/07/24	UPDATED COMPONENTS AND LAYOUT.	SWRS
0	JOL	2007/01/03	INITIAL ISSUE.	LCH
REV.	BY	DATE	DESCRIPTION	CHK'D
BWS Manufacturing Ltd. 10 MONTANA ST. CENTREVILLE, N.B. CANADA E7K 3E9 PH: (506) 276-4567 FAX: (506) 276-4380				UNIT
				3 AXLE AIR RIDE W/ HALDEX 2S/1M, 2 AIR TANKS, AIR LIFT ROLLER
				TITLE
				AIR SCHEMATIC
DRAWN BY	DATE	SCALE	SHI	MODEL
J. O'LEARY	2007/01/03	1/2"=1'-0"	1 OF 1	SN, OF
			DWG. No.	REV
			PS3A212X3-HAL	2



OILFIELD JEEP

2 Axle Air Ride Jeep Dolly
Rev. 0, PS2A211JX-HAL

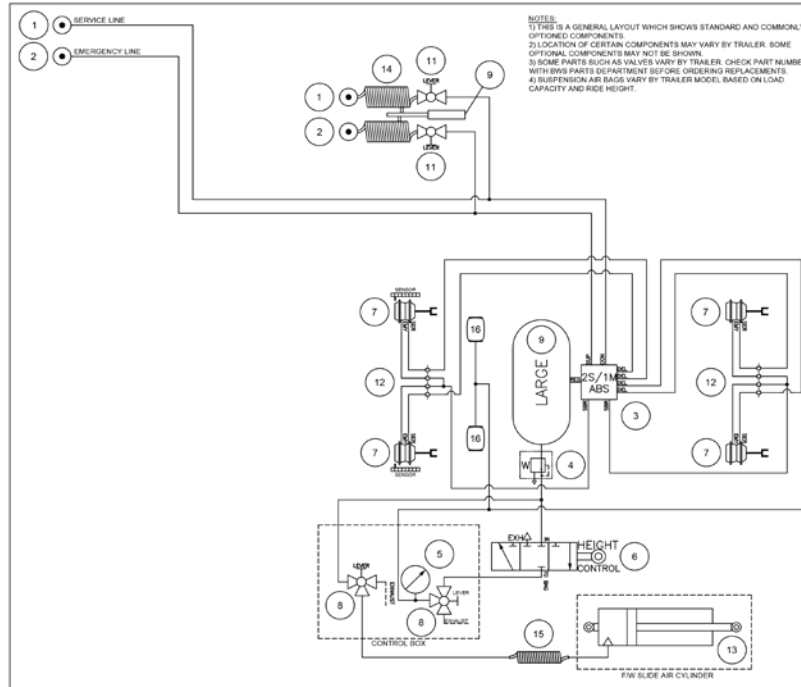

NOTES:
 1) THIS IS A GENERAL LAYOUT WHICH SHOWS STANDARD AND COMMONLY OPTIONED COMPONENTS.
 2) LOCATION OF CERTAIN COMPONENTS MAY VARY BY TRAILER. SOME OPTIONAL COMPONENTS MAY NOT BE SHOWN.
 3) SOME PARTS SUCH AS VALVES VARY BY TRAILER. CHECK PART NUMBER WITH BWS PARTS DEPARTMENT BEFORE ORDERING REPLACEMENTS.
 4) SUSPENSION AIR BAGS VARY BY TRAILER MODEL, BASED ON LOAD CAPACITY AND RIDE HEIGHT.

#	DESCRIPTION	P/N	QTY
1	SERVICE GLAD HAND	40192	2
2	EMERGENCY GLAD HAND	40193	2
3	2S/1M AIR VALVE	401824	1
4	PRESSURE PROTECTION VALVE	40839	1
5	AIR GAUGE BWS	08290	1
6	HEIGHT CONTROL VALVE	40572	1
7	BRAKE POT	402051	4
8	MANUAL DUMP VALVE	63133	2
9	POGO STICK ASSEMBLY	401853	1
10	LARGE AIR TANK	401052	1
11	SHUT OFF VALVE	63135	2
12	AIR HOSE BLACK 3/4" X 24"	40511	8
13	FW SLIDER ASSEMBLY	402189	1
14	HOSE COIL RED AND BLUE	40181	1
15	HOSE COIL BLACK	402230	1
16	SUSPENSION AIR BAG	(NOTE 4)	4

0	LCH	2014/08/06	INITIAL ISSUE -- MODIFIED FROM PS2A211.	
REV.	BY	DATE	DESCRIPTION	CHK'D

	BWS Manufacturing Ltd. 10 MONTANA ST. CENTREVILLE, N.B. CANADA E7K 3E9 PH: (506) 276-4567 FAX: (506) 276-4380		UNIT	2 AXLE AIR RIDE JEEP DOLLY W/ HALDEX 2S/1M, 1 AIR TANK, AIR SLIDE FIFTH WHEEL	
	TITLE AIR SCHEMATIC				
DRAWN BY	DATE	SCALE	SHT	MODEL	DWG. No.
L. HUNTER	2014/08/06	1/2"=1'-0"	1 OF 1	40J02X	PS2A211JX-HAL
					REV
					0

← FRONT OF TRAILER



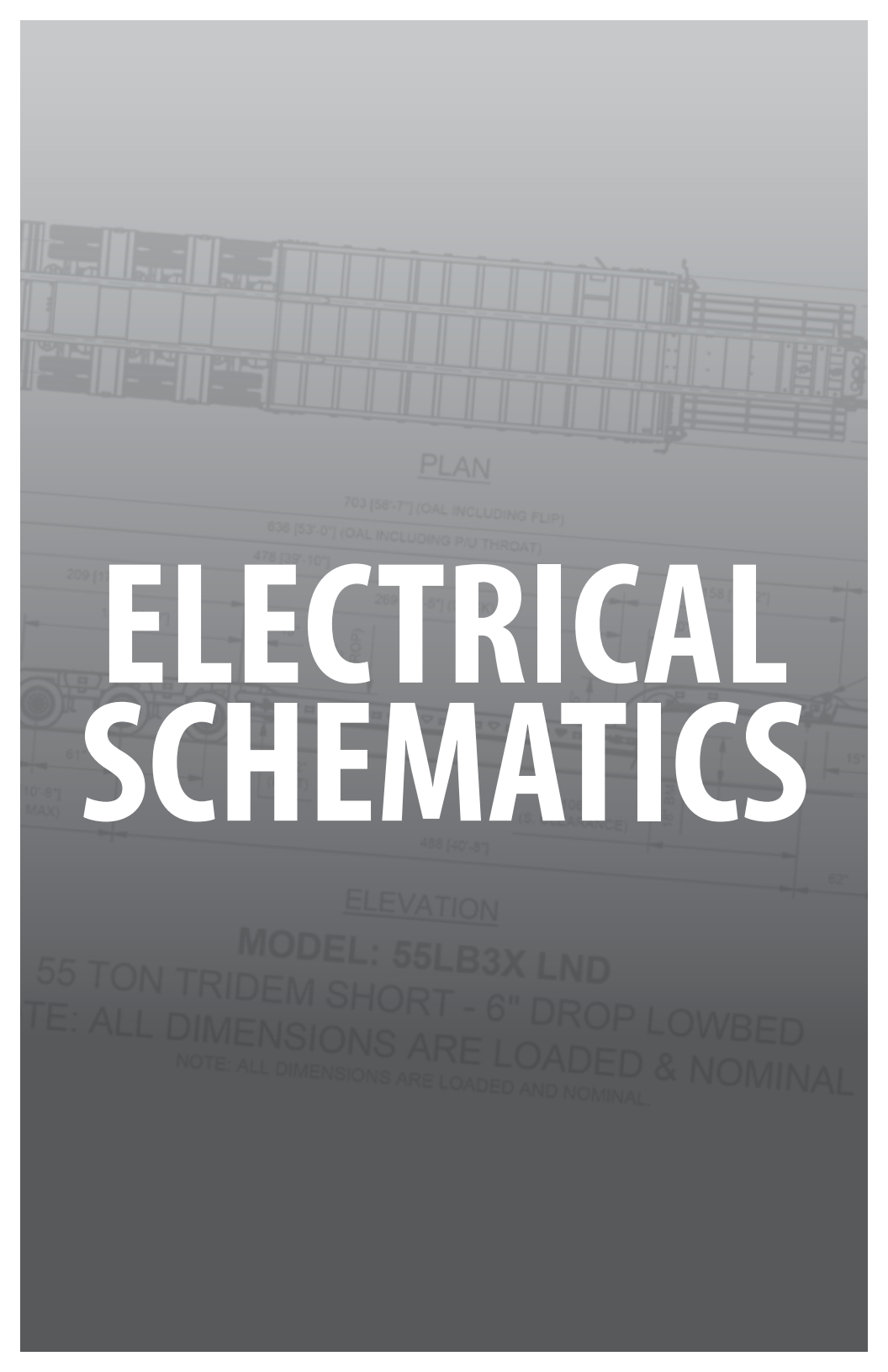

The image shows a technical drawing of a 55-ton tridem lowbed trailer. The drawing includes a plan view at the top and an elevation view below it. The plan view shows the layout of the trailer's frame and axles, with dimensions such as 703 [58'-7"] (OAL INCLUDING FLIP), 636 [53'-0"] (OAL INCLUDING PIU THROAT), and 478 [39'-10"]. The elevation view shows the side profile of the trailer, with dimensions like 408 [40'-8"] and 62". The text "ELECTRICAL SCHEMATICS" is overlaid in large, bold, white letters across the center of the drawing. Below the elevation view, the text "MODEL: 55LB3X LND" and "55 TON TRIDEM SHORT - 6\"

ELECTRICAL SCHEMATICS

ELEVATION

MODEL: 55LB3X LND

55 TON TRIDEM SHORT - 6" DROP LOWBED

NOTE: ALL DIMENSIONS ARE LOADED & NOMINAL

NOTE: ALL DIMENSIONS ARE LOADED AND NOMINAL

BOOSTER

11SB1X

REV.1, WS041

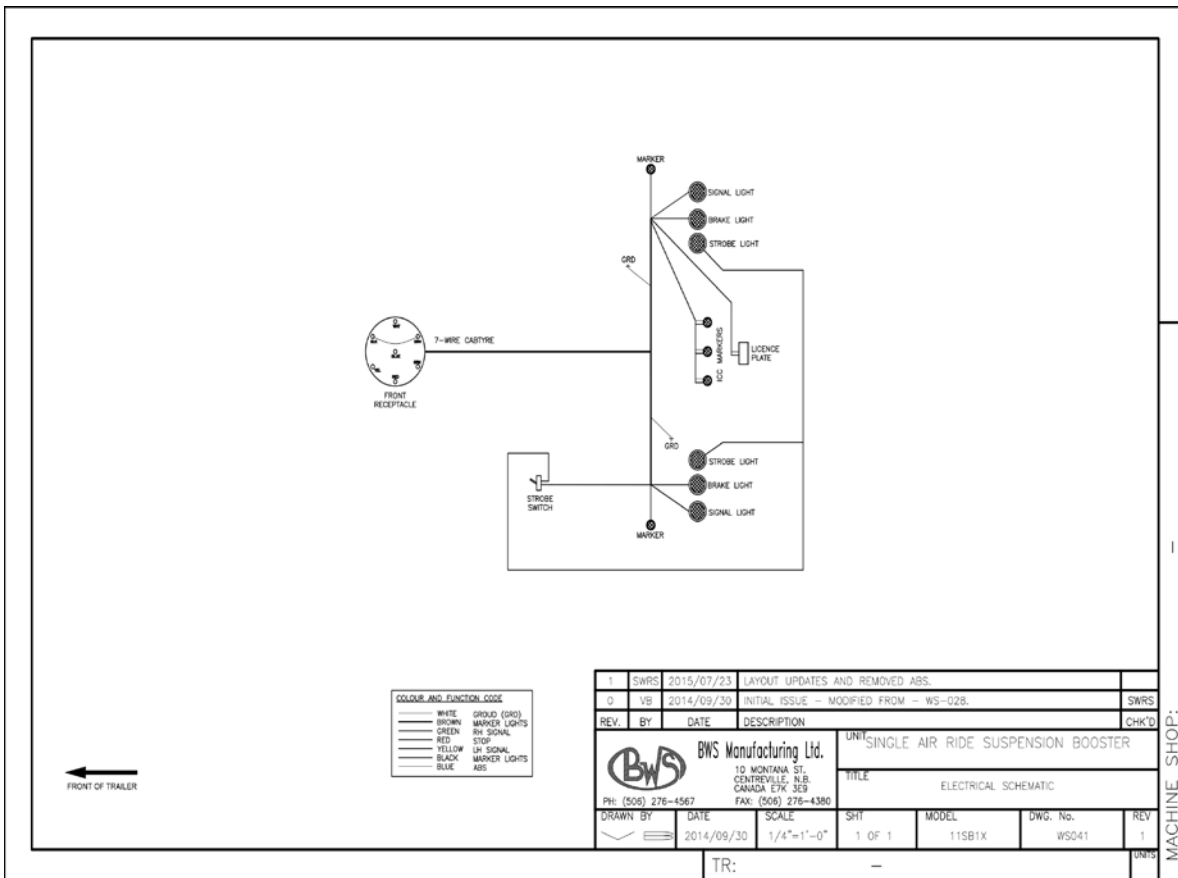

SCISSORNECK

REV.0, WS026

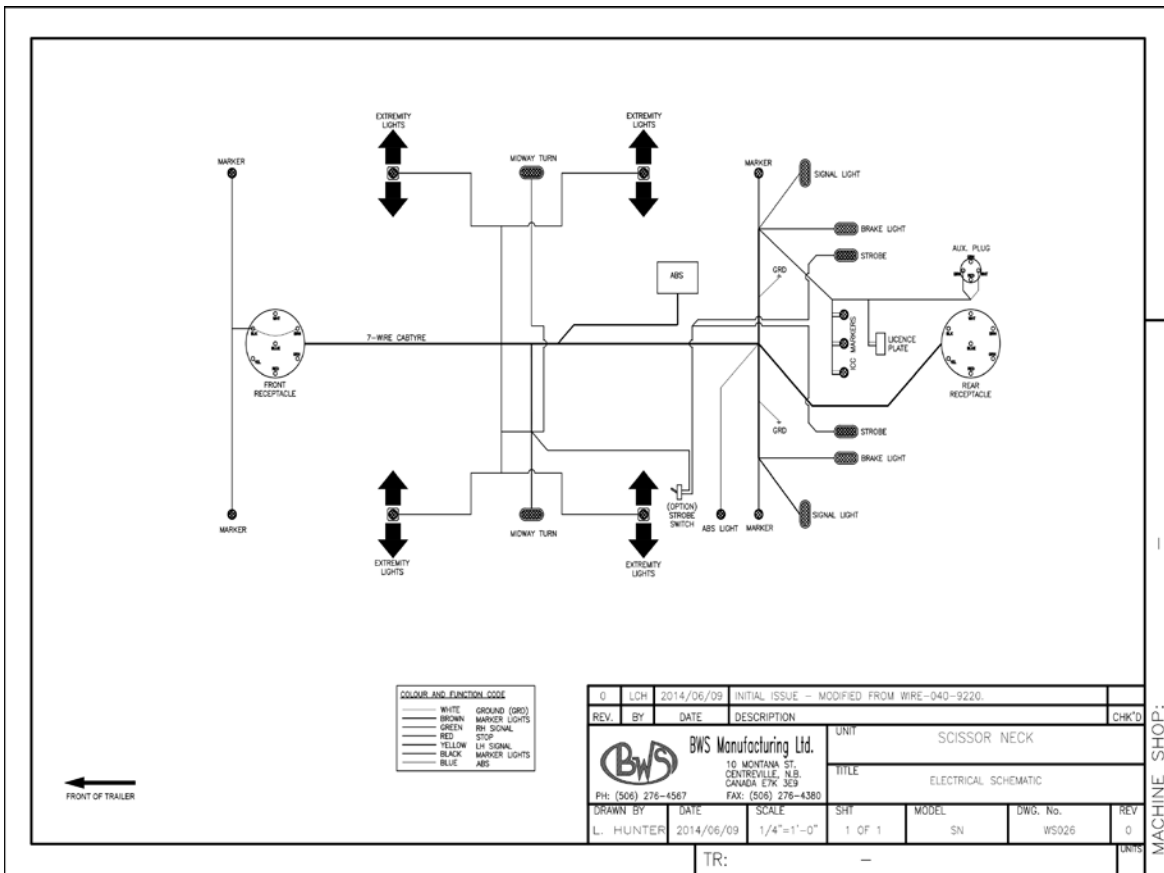

COLOUR AND FUNCTION CODE

WHITE	GROUND (GND)
BROWN	MARKER LIGHTS
GREEN	RT SIGNAL
RED	STOP
YELLOW	LT SIGNAL
BLACK	MARKER LIGHTS
BLUE	ABS

0	LCH	2014/06/09	INITIAL ISSUE - MODIFIED FROM WIRE-040-9220.	
REV.	BY	DATE	DESCRIPTION	CHK'D
			BWS Manufacturing Ltd. 10 MONTANA ST. CENTREVILLE, N.B. CANADA, E7K 3E9 PH: (506) 276-4567 FAX: (506) 276-4380	
DRAWN BY			DATE	SCALE
L. HUNTER			2014/06/09	1/4"=1'-0"
SHT		MODEL	DWG. No.	REV
1 OF 1		SN	WS026	0
TR:				UNITS

MACHINE SHOP:



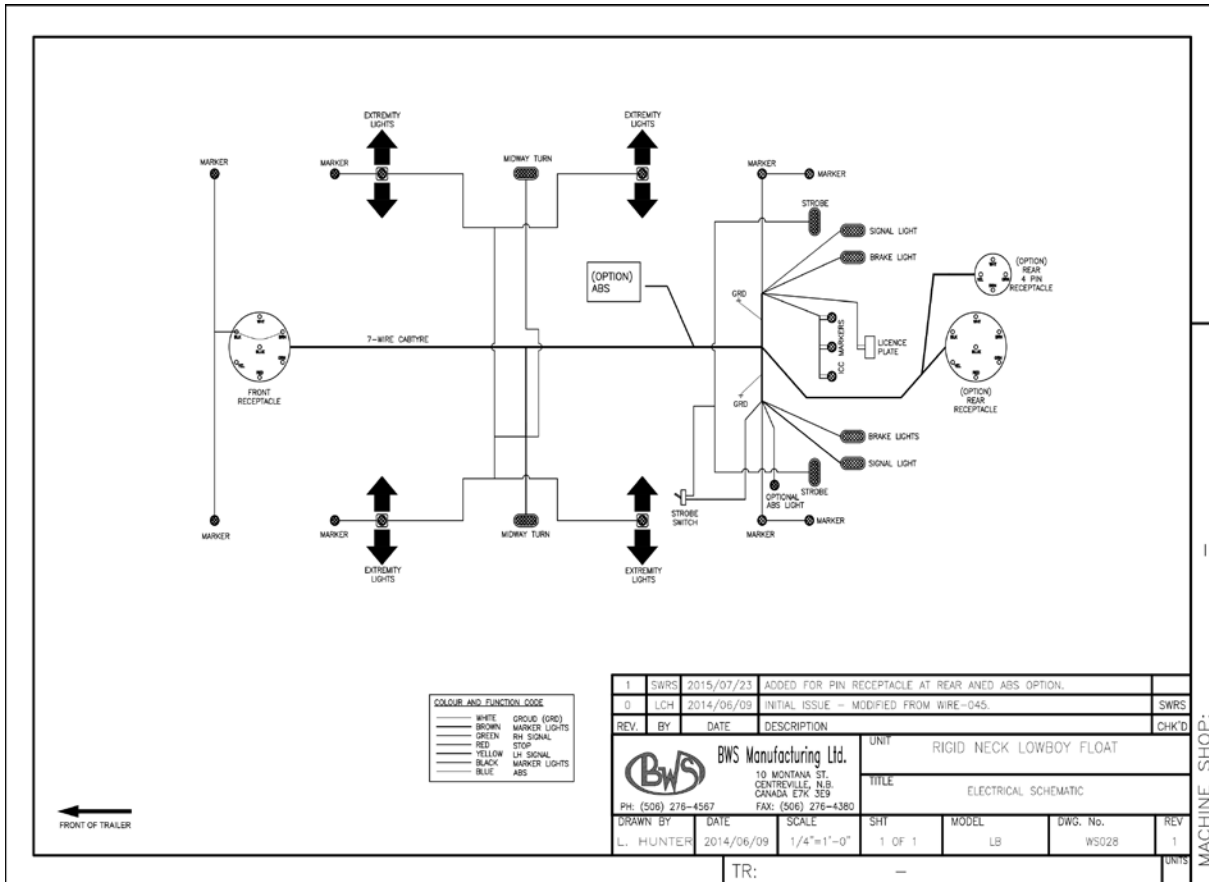

1	SWRS	2015/07/23	ADDED FOR PIN RECEPTACLE AT REAR AND ABS OPTION.		
0	LCH	2014/06/09	INITIAL ISSUE - MODIFIED FROM WIRE-045.		SWRS
REV.	BY	DATE	DESCRIPTION		CHK'D
			UNIT RIGID NECK LOWBOY FLOAT TITLE ELECTRICAL SCHEMATIC		
BWS Manufacturing Ltd. 10 MONTANA ST. CENTREVILLE, N.B. CANADA E7Y 3Z9 PH: (506) 276-4567 FAX: (506) 276-4360					
DRAWN BY	DATE	SCALE	SHT	MODEL	DWG. No.
L. HUNTER	2014/06/09	1/4"=1'-0"	1 OF 1	LB	WS028
TR: -					REV 1
					UNITS

MACHINE SHOP: 1

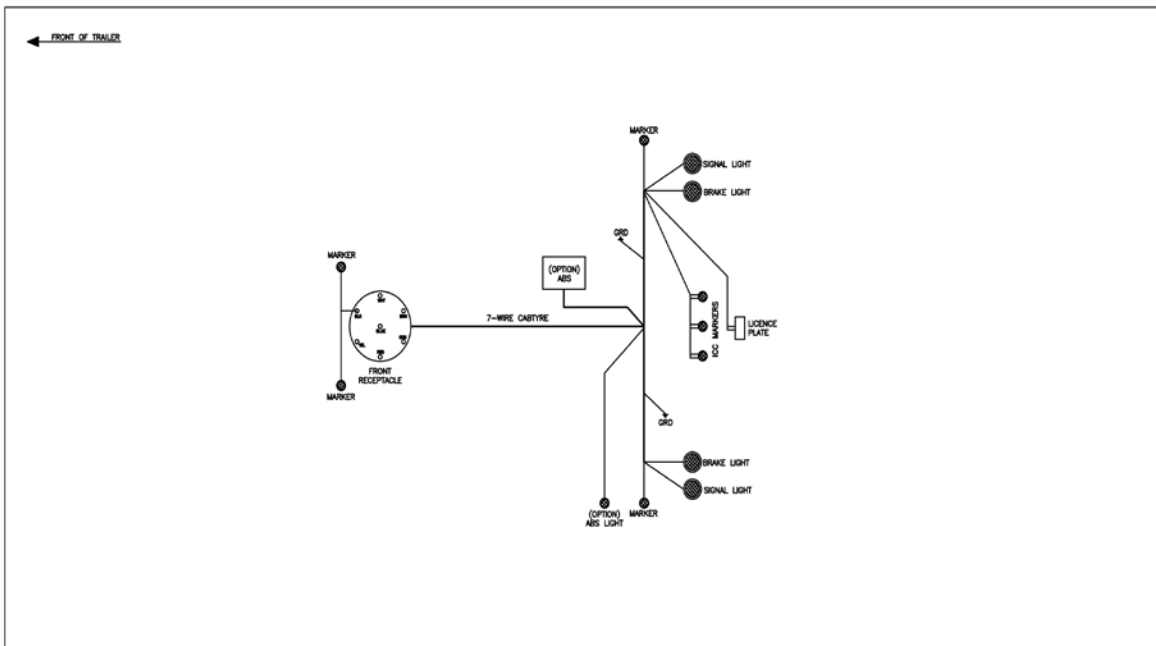

COLOR AND FUNCTION CODE

WHITE	GROUND (GRD)
BROWN	MARKER LIGHTS
GREEN	RH SIGNAL
RED	STOP
YELLOW	LH SIGNAL
BLACK	MARKER LIGHTS
BLUE	ABS

1	LCH	2014/06/16	ADDED OPTIONAL ABS - MISSING IN REV 0	
0	LCH	2014/06/09	INITIAL ISSUE - MODIFIED FROM WIRE-015	LCH
REV.	BY	DATE	DESCRIPTION	CHK'D

BWS Manufacturing Ltd. 10 MONTANA ST. CENTREVILLE, N.B. CANADA E7K 5E9 Ph: (506) 276-4567 Fax: (506) 276-4390		UNIT		20T & 40T JEEP DOLLY			
		TITLE		SINGLE AND TANDEM AXLE			
DRAWN BY		DATE	SCALE	SHT	MODEL	DWG. No.	REV
L. HUNTER		2014/06/09	1/4"=1'-0"	1 OF 1	JD	WS021	1

TR: - UNITS

MACHINE SHOP:

7.0 CONTROL BOXES

SUSPENSION CONTROL (RA019SA-B150)



RA019SA-B150 Suspension Control

S/N - 3561404
B150S/N - B1425-0089

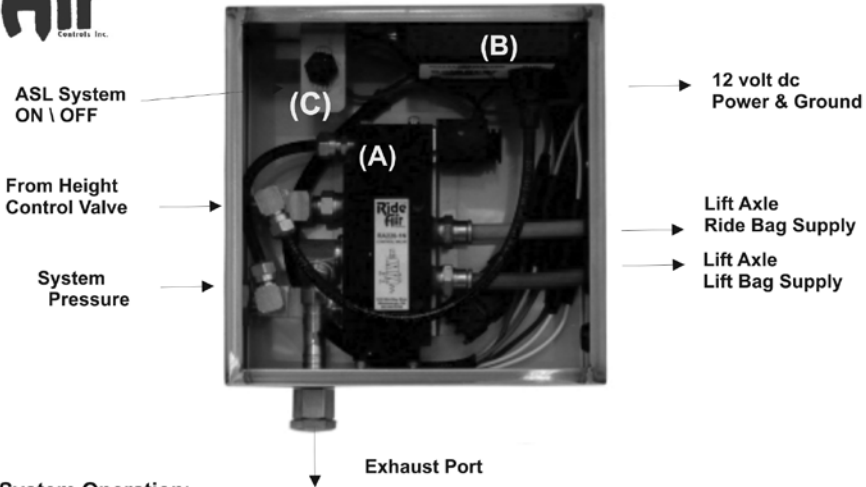

System Operation:

With Switch (C) on, the ASL (auto sensing lift) System will function automatically. Axle (s) will lift when the trailer is empty. Axle (s) will automatically lower when the trailer is loaded.

With the Switch (C) in the off position, all axles will remain down.

The B150 Balancer module is factory set to lift axle(s) when the trailer is unloaded and lower all axles when a load is detected. With the control knob down the lift axles will be locked up.

THE B150 CAN ONLY BE ADJUSTED BY AN AUTHORIZED DEALER

Component List:

- | | | |
|----------------|---------------------------|--|
| (A) - RA220-1N | - Lift Axle Control Valve | (B) RM-B150 - Balancer - Electronic Control Module |
| (C) - RP34-571 | - Toggle switch | (D) RA001TS - Stainless Steel Box |
| (D) - S110524 | - Exhaust Filter | |

SUSPENSION CONTROL (RA019SA-B150)



RA016SRA-31L80 Suspension Control

S/N -0000000

Steer Axle Lock Chamber Supply - valve (H)
Lift Axle Service Brake Line Out - valve (F)
Lift Axle Service Brake Line In

Height Control Supply-Line In

Air Tank Supply Line In

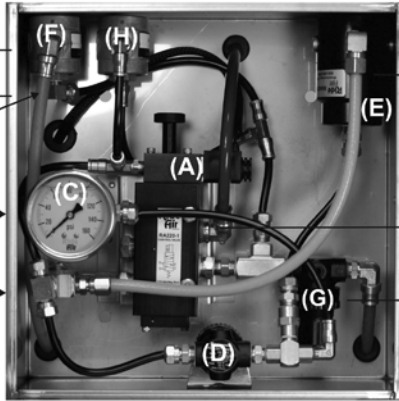

Steer Axle Torpress Bag Supply - valve (E)

Lift Axle Ride Bag Supply

Lift Axle Lift Bag Supply

System Operation:

Lift Axle Down: With the manual control knob up, the steer/lift ride bags will fill to the system pressure..

Lift Axle Up: Supply 12 volt DC power to the solenoid (the manual control knob must be up) OR manually push the control knob in, rotate to lock.

Component List:

(A) - RA220-1 - Lift axle solenoid valve
(C) - RA325CL - Liquid Gauge
(D) - RA615 - Preset Regulator

(E) - RA6210 - 2:1 Ratio Regulator
(F) - RA510 - Pilot Valve
(G) - RA615-80 - Preset Regulator
(H) - RA510 - Pilot Valve
(I) - RA001BSR -Stainless steel box (only)

SUSPENSION DUMP CONTROL (RA014GL)



RA014GL Suspension Dump Control

S/N - 0051203



- OPERATION : With control valve handle down - as pictured - air ride system will be activated
: To dump air from ride system, rotate handle 90 degrees to the right

8.0 TROUBLE SHOOTING

PROBLEM	PROBABLE CAUSE	CORRECTIVE ACTION
COUPLER LOCK DOES NOT FULLY ENGAGE	Dirt or gravel contamination.	Wash and inspect.
	Worn parts.	Check fifth wheeling locking adjustment (see Maintenance Section).
	Mechanism improperly adjusted.	Check for excessive wear.
EXCESSIVE OR UNEVEN TIRE WEAR	Over or under inflation.	Inflate to recommended pressure.
	Loose wheel nuts or clamps.	Tighten wheel nuts or clamps to recommended torque.
	Loose or tight wheel bearing.	Adjust bearings.
	Axle bent or out of alignment.	Straighten, align or replace axle.
	Tires not properly matched.	Match tires.
	Improper acting brakes.	Correct brakes as required.
	Rapid stopping.	Apply brakes slowly when approaching stops.
	Excessive speed on turns.	Reduce speed.
*See your tire dealer for any tire issues.		
SCUFFED TIRES	Over or under inflation.	Inflate to recommended pressure.
	Excessive speed on turns.	Reduce speed.
WOBBLY TIRES	Tire wobble due to uneven rim clamping.	Torque tighten all rim clamps.
	Worn or damaged wheel bearings.	Replace bearings.
	Broken or bent wheel or rim.	Replace wheel or rim.
	Bent axle.	Replace or straighten axle.
	Broken wheel studs.	Replace wheel studs.
DOG TRACKING	Blown air bag.	Replace air bag.
	Bent axle.	Replace or straighten axle.
	Frame or suspension (axles) out of alignment.	Straighten frame or align axles.
	Worn or damaged torque arms or bushings.	Check or replace.

8.0 TROUBLE SHOOTING

PROBLEM	PROBABLE CAUSE	CORRECTIVE ACTION
LOSS OF TIRE AIR PRESSURE	Puncture in tire.	Repair or replace tire.
	Faulty valve or valve core.	Replace valve assembly or core.
	Wheel or rim damage.	Replace wheel or rim.
BRAKES DO NOT APPLY EVENLY	Brake valve(s) not operating correctly.	Check brake adjustment and related items.
	Loading of trailer not proportional.	Redistribute load.
BRAKES DO NOT RELEASE	Brake shoe bound up at anchor pins.	Lubricate brake operating parts.
	Brake hoses restricted.	Replace hoses.
	Brakes out of alignment.	Adjust brakes.
	Damaged brake assembly.	Replace damaged parts.
	Contaminated air valves.	Clean or replace.
	Tractor lines crossed.	Attach properly.
NO BRAKES OR INSUFFICIENT BRAKES	Source of air supply shut off at tractor.	Open cutout cocks at rear of tractor cab or push control valve "IN".
	Disconnected or not properly coupled glad hands.	Connect or properly couple glad hands.
	Lower brake line pressure.	Check air pressure gauge on tractor or for inoperative compressor.
	Brake pads worn or glazed.	Replace pads.
	Reservoir drain valve open.	Close drain valve.
GRABBING BRAKES	Oil, grease or foreign material on brake lining.	Reline brakes.
	Brakes out of adjustment.	Adjust brakes.
	Brake drum out-of-round.	Replace brake drum.
	Damaged brake chamber or internal assembly.	Replace complete brake chamber.
	Leaking or broken hose between valve and brake chamber.	Replace or repair as required.

8.0 TROUBLE SHOOTING

PROBLEM	PROBABLE CAUSE	CORRECTIVE ACTION
BRAKES DRAGGING	Brakes set too tight.	Adjust brakes (slack adjuster).
	Binding cam, anchor pins or chamber rod end pin.	Lubricate and free up.
	Diaphragm is leaking in brake chamber.	Replace broken chamber.
	Air valve contamination.	Clean and replace.
	Damaged brake assembly or brake drum out of round.	Replace.
SLOW BRAKE APPLICATION OR RELEASE	Lack of lubrication.	Lubricate brake operating parts.
	Excessive travel in brake chamber push rod.	Adjust brakes.
	Restriction in hose or lines.	Repair or replace.
	Defective brake valve (s).	Replace defective valve(s).
ALL AIR SPRINGS FLAT	Insufficient air supply.	Build up and maintain tractor air pressure at least 90 psi.
		Check couplings and valves from tractor and trailer.
	Air spring leaking or punctured	Replace air spring.
	Leaking or broken air line in air suspension system.	Inspect and test for leaks or pinched lines, repair.
	Malfunctioning height control valve.	Inspect, test and replace as required.
ONE AIR SPRING FLAT	Air spring leaking or punctured.	Replace air spring.
	Supply lines pinched or broken.	Repair or replace.
AIR SUSPENSION DEFLATES RAPIDLY WHEN PARKED.	Leak in air system.	Locate and repair leak(s).
TRAILER RIDES TOO HIGH OR TOO LOW.	Improperly adjusted height control valve.	Check height and readjust height control valve.
	Faulty valve.	Inspect and repair.

8.0 TROUBLE SHOOTING

PROBLEM	PROBABLE CAUSE	CORRECTIVE ACTION
	Control valve linkage broken or disconnect.	Inspect and repair.
EXCESSIVE SHOCK ABSORBER WEAR.	Defective height control valve.	Replace valve.
	Damaged air spring.	Replace air spring(s).
HEIGHT CONTROL VALVE NOT FUNCTIONING.	Dirt or foreign matter in air supply line.	Check and clean air filter. Inspect, clean or replace height control valve.
DIM OR FLICKERING LIGHTS.	Battery on tractor not sufficiently charged.	Charge battery.
	Bad connection.	Check electrical system circuits.
	Damaged wire in jumper cable.	Repair or replace cable.
	Poor ground sockets.	Repair as necessary.
COMPLETE LOSS OF TRAILER LIGHTS.	Broken main harness.	Repair or replace.
	Frayed wires.	Check circuit breaker at front.
	Broken/damaged jumper cable.	Replace jumper cable.
	Loose or corroded connection in ground lead between tractor and trailer.	Repair or replace.

9.0 WARRANTY

BWS Manufacturing Ltd. - Warranty Procedures

FOR ASSISTANCE, PLEASE CALL SERVICE

Monday - Friday

8:00am-5:00pm AST

Toll Free: 1.888.896.5777

Local: 1.506.391.5878

Email: warranty@bwstrailers.com

BWS CONTACT INFORMATION

29 Hawkins Road, Centreville, NB - E7K 1A4

For more information, contact the nearest BWS Manufacturing authorized dealer or visit www.bwstrailers.com where a warranty claim can be made.

STRUCTURAL & COMPONENT WARRANTY

1 YEAR BUMPER TO BUMPER	Warrants that the specified BWS equipment will be free from defects in materials and workmanship, under normal use and service, for the period of the first 12 months or regular service post the date-in-service. This warranty extends only to the original first owner. It is not transferable and applies only to OEM installed components and equipment.
3 YEAR PAINT AND FINISH	Steel Shot Blast Industrial top coat and oven baked finish is warranted against defects in materials and workmanship (140 degrees for 75 minutes) Custom colours are subject to a 1 year warranty only Does not cover against general wear and tear such as stone chips or fade as of 2016.
5 YEAR SUPER STRUCTURE	Warrants the trailer main frame beams or "super structure" (consisting of the top and bottom flanges, and their connecting web) to be free from defects in materials and workmanship, under normal use and service for a period of 5 years from the date-in-service only to the original first owner.
SUSPENSION	Ridewell holds a 5 year warranty on all beams and bushings. Hutch has a 5 year warranty on manufacturer defects.
6 YEAR BRAKES	Haldex Platinum Warranty to the 1st owner Life Seal equipped Haldex ABS component brake system slack adjusters/brake chambers (Haldex LifeSeal)/ABS system ECM & control valve. 6 year or one (1) million mile warranty against defects in material or workmanship.
7 YEARS LIGHTING	Grote Ultra Blue 7 year warranty on the male pin harness 10 year warranty on tail lights

***No warranty what-so-ever on tires or ABS Sensor Alignment.*

HALDEX WARRANTY

The Haldex warranty information can be found at www.haldex.com and then by searching warranty.



HARD WORKING TRAILERS

FOR HARD WORKING PEOPLE



www.bwstrailers.com
toll free 888.896.5777



9001:2015
CERTIFIED

