

BWS P/N:40959553 REV: 11



GENERAL OPERATOR'S MANUAL
DECEMBER 2021

www.bwstrailers.com
toll free 888.896.5777



ISO 9001:2015
CERTIFIED

TABLE OF CONTENTS

INTRODUCTION	6
PRODUCTS	6
BWS COMPANY HISTORY	7
QUALITY POLICY	8
COMPLIANCE PLATE	9
HUB ALERT™	10
1.0 SAFETY PRECAUTIONS	11
1.1 OPERATING SAFETY	12
1.2 MAINTENANCE SAFETY	12
1.3 LOADING SAFETY	12
1.4 SAFETY DECAL MAINTENANCE	12
1.5 SIGN-OFF FORM	12
2.0 SAFETY DECALS	14
3.0 OPERATING PROCEDURES	15
3.1 BREAK-IN/INSPECTION	15
3.1.1 500 mile / 800 km Inspection	15
3.1.2 10,000 mile / 16,000 km Inspection	15
3.1.3 20,000 mile / 32,000 km Inspection	15
3.2 PRE-OPERATION VEHICLE INSPECTION PROCEDURE	16
Walk Around Sequence	16
3.3 PRE-OPERATION VEHICLE INSPECTION PROCEDURE (TAG TRAILERS)	19
Walk Around Sequence	19
3.4 FIFTH WHEEL OPERATING INSTRUCTIONS	20
3.4.1 Coupling Procedure	20
3.4.2 Uncoupling Procedure	20
3.5 LOADING	21
3.5.1 Trailer Weight Distribution	21
3.5.2 Load Restraints	22
3.6 TRANSPORTING	23
3.6.1 Braking Guidelines	23
3.6.2 Tires	23
4.0 QUARTER FRAME DUMP	24
4.1.1 Pre-Operation Vehicle Inspection Procedure	24
4.1.2 General Trailer Components	24
4.1.3 Pivot Pins	24
4.1.4 Bolted Hinge Connections	25
4.1.5 Tailgate Air Controlled Latch	25
4.1.6 Alignment Brackets	25
4.2 TAILGATE OPERATION	26
4.2.1 Vertical Swing Mode	26
4.2.2 Horizontal Swing Mode	27
4.2.3 Greasing	28
4.3 GENERAL TRAILER COMPONENTS	28
4.4 MAIN PIVOT BUSHINGS	28
4.5 GREASING	28
4.6 HYDRAULIC LIFT CYLINDER	28

TABLE OF CONTENTS

4.7 LOADING	29
4.8 DUMP OPERATION	29
4.9 DECALS	30
4.10 AIR SYSTEM	30
4.11 TARP	30
5.0 EQUIPMENT & TAG TRAILER REAR AIR RAMP OPERATION	31
5.1 GOOSENECK UPPER DECK AIR RAMP OPERATION	31
5.2 HYDRAULIC AND ELECTRIC WINCH OPERATION	32
6.0 MAINTENANCE AND INSPECTION	33
6.1 KING PIN AND UPPER COUPLER	34
6.2 AXLES	35
6.2.1 Suggested Preventative Maintenance Schedule	35
6.2.2 Axle Alignment	35
6.2.3 Wheel Hubs	37
6.2.4 Bearing Adjustment Procedure	38
6.2.5 Bearing Adjustment	39
6.3 GREASE RETAINERS OIL SEALS	40
6.3.1 Ring and Seal Type (Oil) Maintenance	40
6.3.2 Ring and Seal Type (Oil) Replacement	40
6.4 SUSPENSION SYSTEM (AIR)	40
6.4.1 Inspection	40
6.5 SUSPENSION SYSTEM	41
6.5.1 Mechanical Suspension	42
6.5.2 Hutch Suspension System	42
6.5.3 Radius Rods	43
6.5.4 Rocker Bushings and Hangers	43
6.6 AIR RIDE SUSPENSION	43
6.6.1 Maintenance	45
6.6.2 Pivot Connection	45
6.6.3 Air Control System	45
6.6.4 Height Control Valve	46
6.6.5 Height Control Valve with Dual Ride Height	46
6.6.6 Air Dump Valve	47
6.7 BRAKES	47
6.7.1 Preventative Maintenance	47
6.7.2 Maintenance	49
6.8 TIRES	50
6.8.1 Tire Care and Maintenance	50
6.8.2 Tire Inspection	50
6.8.3 Mechanical Irregularities	51
6.8.4 Radial Tire Application	51
6.8.5 Matching Tires to Rims	51
6.8.6 Tire Wear Patterns:	52
Over Inflation	
Under Inflation	
Feathering	
One Side Wear	
Cupping	
Second Rib Wear	

TABLE OF CONTENTS

6.9 AIR SYSTEM COMPONENTS	53
6.9.1 Glad Hands	53
6.9.2 ABS	53
6.10 ELECTRICAL SYSTEM	54
7.0 AIR SCHEMATICS	55
SUSPENSION HIGHWAY	56
HF2X, 48HD2X	
HIGHWAY	57
HF3X, 51LF3X3T SK, 53LD3X3T BC	
JEEP	58
20JD1X	
JEEP	59
40JD2X WL	
JEEP	60
60JD3X	
HIGHWAY / LOGGING B-TRAIN (BC&NL)	61
32HBT3XHD, 37LBT3X (Lead)	
LOGGING B-TRAIN	62
37LBT3XNFLD (Lead)	
HIGHWAY / LOGGING B-TRAIN	63
28HBT2XHD, 27LBT2X (Pull)	
LOGGING	64
46LD3X4T, 48LF3X5TNB (3 Axle with Front Lift Axle)	
LOGGING	65
46LF4X-NL (Lift Axle, Steer Lock, and Load Binders)	
LOGGING	66
51LF4X5TNB, 51LD4X5T NS/NB (Lift Axle, Steer Lock)	
LOGGING	67
50LF4X3T AB (Lift Axle)	
LOGGING	68
50LF3X3T AB (4th Axle Ready)	
DUMP TRAILER	69
27DT2X	
DUMP TRAILER	70
37DT2X	
ET & TAG	71
ET2X, ART, ANR, NTT (2 Axle, Air Suspension)	
ET & TAG	72
ET3X, ART, ANR, NTT (3 Axle, Air Suspension)	
TAG	73
ANR, ART, NTT (2 Axle, Spring Suspension)	
TAG	74
ANR, ART, NTT (3 Axle, Spring Suspension)	
TAG	75
ANR, ART, NTT (Combination Spring Suspension)	
TAG	76
ANR, ART, NTT (Combination Spring Suspension)	

TABLE OF CONTENTS

8.0 ELECTRICAL SCHEMATICS	77
JEEP	78
20JD1X, 40JD2X WL, 60JD3X	
DUMP TRAILER WITH OPTIONAL LIFT SOLENOID	79
27DT2X, 37DT3X	
HIGHWAY & EQUIPMENT TRAILERS	80
53HF3X, 48ET3X, 48HD2X	
LOGGING, SINGLE DROP TRAILER	81
ALL LOGGING DROPS (ex: 53LD3X3T)	
LOGGING TRAILER, FLAT	82
ALL LOGGING FLATS (ex. 53LF4X5T)	
LOGGING B-TRAIN TRAILERS	83
37LBT3X, 27LBT2X	
TAG TRAILERS	84
ANR, ART, NTT (INCLUDES 20TON, 25TON, 30TON)	
10.0 CONTROL BOXES	85
SUSPENSION DUMP / TAILGATE CONTROL (RA011-DG)	86
27DT	
SUSPENSION TAILGATE CONTROL (RA011A-DG3)	87
37DT	
SUSPENSION CONTROL (RA016SSA-21LS)	88
51LD4X5T ON 2016, 48LF4X5T NB V2016, 51LF4X5T NB V2016	
RA013 - DUAL - 3 DUAL SUSPENSION CONTROL	89
48LD4X4T NB 2017	
RA013S SUSPENSION CONTROL	90
53ET3XP, 46LF3X4T NS V2017, 48LF3X5T NB V2016, 30 ART (AIR SUSP.)	
RA0122S LIFT AXLE CONTROL	91
25ANR, 25ART, 30ANR	
SUSPENSION CONTROL RA019SA - B150	92
53ET3X, 27LBT2X	
11.0 TROUBLE SHOOTING	93
12.0 WARRANTY	97
12.1.1 Structural & Component Warranty	97

INTRODUCTION

The BWS product you have just taken delivery of has been carefully designed and built for easy, low maintenance, reliable operation that meets the requirements of a shrewd transportation industry.

We take this opportunity to thank you for choosing BWS, and assure you of our interest in the continued safe and reliable operation of this equipment through its' dealer and service network abroad. BWS trailers require that you and anyone else who will be operating or maintaining the trailer, read this manual carefully and understand the Safety, Operation, Maintenance and Trouble Shooting information contained in the Operator's Manual.

PRODUCTS

TAG A LONG

- Air Ramp Tilt
- Air Tilt, No Ramp
- Non Tilt Tag
- Flat Deck, Non Tilt

DOUBLE DROP

- Air Detachable Gooseneck
- Air Detachable Gooseneck AG
- Mechanical Detachable
- Mechanical Detachable EXT
- Mechanical Detachable AG
- Hydraulic Detachable AG
- Hydraulic Detachable AG ULP
- Hydraulic Detachable AGNR
- Hydraulic Detachable Mini

HEAVY HAUL

- Hydraulic Detachable
- Hydraulic Detachable Elite
- Hydraulic Detachable Heavy
- Hydraulic Detachable Heavy Haul
- Flip Axle
- 40 - 60 Ton Jeep 1/2/3 Axles

DROPDECK

- Highway B-Train
- Highway Flat
- Highway Drop

OILFIELD

- Rigidneck
- Scissorsneck
- Oilfield Jeep
- Oilfield Float
- Single Axle Booster
- 40 - 60 Ton Jeep 1/2/3 Axles

EQUIPMENT

- Equipment Trailer
- Equipment Trailer Paving & Recovery

LOGGING

- Western Logger BTrain
- Western Logger AB/SK
- Western Logger Jeep
- Eastern Logger NB/NS/QC
- Eastern Logger NFLD
- Eastern Logger BTrains NFLD

SPECIALIZED

- Cable Reel Trailer
- Nuclear
- Hopper Sander
- U Body Dump
- Turnkey Truck
- Scrap B-Train
- Land Pro
- Pitpro 360 Screener

END DUMP & LIVE

BOTTOM

- Dump Trailer
- Live Bottom

BWS COMPANY HISTORY

Our Trailers are engineered, designed and manufactured by BWS, located in Centreville, New Brunswick. It is a family owned and managed business that is dedicated and committed to delivering outstanding value. Its success is built on thinking like the customer and producing trailers that can be relied on year after year without fail.

Since 1967, it has gained and maintained the trust and respect of experienced customers who work in the oil fields, construction, equipment and machinery moving, forestry, road building, paving and private contracting industries.

Originally BWS manufactured custom trailers with a focus on forestry and agriculture. Having built a solid reputation in this rough off-road industry and operating in the tough Canadian environment, BWS continues today to manufacture trailers that are designed to meet the customers' expectations in the environments in which they operate. The units are designed to go to work and stay at work.

BWS has expanded its product line into areas where it can continue to provide high quality solutions that deliver value.

The employees of BWS are a dedicated workforce with a "craftsman" mentality. Many of its senior people have past experience operating trailers and equipment and this has resulted in their philosophy of putting themselves in the shoes of their customers. BWS relies heavily on feedback from both their dealers and their customers. They build what performs, not just what sells and that is what has contributed to their significant growth throughout North America over the last several years.





**CERTIFIED
CSA W47.1**



QUALITY POLICY

BWS is totally committed to understanding and meeting the quality needs and expectations of all our customers. Our company has a proud reputation for delivering quality equipment and components.

We strive for continuous improvement of our product and meeting the objectives of the company. We are also committed to the continuous improvement of our quality management system to insure its suitability to meet all company, customer, regulatory, legal and ISO requirements.

The entire BWS team will adhere to the spirit and intent of our quality policy, as well as the directives of this quality assurance manual and its supporting quality system documentation. We will continue to aggressively strive to insure that customer satisfaction is achieved at all times, and in all things.



Hugo St-Cyr
CEO



Jamie Merrithew
Systems Manager



COMPLIANCE PLATE

The compliance plate is located on the road side of the trailer frame. The National Safety Mark (NSM) verifies compliance with all applicable Canadian Motor Vehicle Safety Standards (CMVSS) and/or American Federal Motor Vehicle Safety Standards (FMVSS), and records the following information.

V.I.N. Vehicle Identification Number
DATE Date of Manufacture
TYPE (TRA/REM) in Canada only
MODEL BWS Trailer Model
G.V.W.R Gross Vehicle Weight Rating is the sum of the trailer weight and the allowable trailer load.

G.A.W.R Gross Axle Weight Rating is the lowest capacity of all the individual components in the axle assembly. It reflects the "weakest link" in the entire suspension system, whether it be springs, axles, wheels, rims or tires.



RIM Rim Diameter x Width
TIRE Outside Diameter/ Width R Inside Diameter

PRESSURE COLD Cold tire inflation pressure in psi (US) / kPa and psi (Can.)

It is the practice of BWS to use maximum pressure for tire inflation.

NSM BWS has been assigned a registration number and has been authorized to use the NSM on their products. The NSM signifies conformance with the CMVSS set by transport Canada.

COMPLIANCE PLATE

MANUFACTURED BY / FABRIQUÉ PAR:  CENTREVILLE NEWNOUVEAU BRUNSWICK CANADA			TYPE OF VEHICLE / TYPE DE VÉHICULE: TRA / REM MODEL / MODÈLE: 0 GVWR / PNBY: 0 KG 0 LB TARE: 0 KG 0 LB DOM / DDF: 0 M/M 0 Y/A VIN / NIV: 0					
GAWR / PNBE			MAX SPEED (LOADED / UNLOADED): 70MPH / 110 MPH				COLD INFLATED PRESSURE	
			RIM / JANTE		TIRE / PNEU		PRESS. DE GONFLÉ À FROID	
POSITION	KG	LB	DIMENSION	DIMENSION	S/S	D/J	KPA	PSI / LPC
FR/AV	0	0	0	0			0	0
INT 1:								
INT 2:								
RR/AR								
THIS VEHICLE CONFORMS TO ALL APPLICABLE U.S. FMVSS AND CANADIAN CMVSS IN EFFECT ON THE DATE OF MANUFACTURE SHOWN ABOVE. CE VÉHICULE SE CONFORME A TOUS LES ÉTATS-UNIS APPLICABLES FMVSS ET CMVSS CANADIEN EN EFFET LA DATE DE LA FABRICATION MONTRÉE CI-DESSUS.								

HUB ALERT™

HEAT SENSING LABELS IDENTIFY POTENTIAL BRAKE, BEARING OR SEAL ISSUES BEFORE THEY CAUSE COSTLY REPAIRS!

THE NORMAL OPERATING
TEMPERATURE OF HUB/HUBCAP
GREASE OR OIL SHOULD NOT EXCEED
225°F (107°C).

- HUB ALERT™ will alert you to above normal wheel end operating temperature!
-
- HUB ALERT™ heat sensing label will turn **BLACK** when hub/hubcap surface temperature reaches 250°F (121°C).
-
- HUB ALERT™ indicates the need for a more detailed inspection of the overheating wheel end.
-
- New HUB ALERT™ label is applied to the hub/hubcap after resolving overheating issues

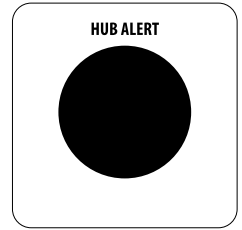
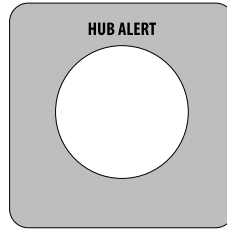

SAFETY PRECAUTIONS

SAFETY ALERT SYMBOL

This safety Alert symbol means

**ATTENTION! BECOME ALERT!
YOUR SAFETY IS INVOLVED!**



NEEDS DETAILED INSPECTION

Remember, YOU are the key to safety. Good safety practices not only protect you but also the people around you. Make these practices a working part of your safety program. Be certain that EVERYONE operating this equipment is familiar with the recommended procedures and follows all safety precautions. Do not risk injury or death.

Remember the difference between being a driver and an efficient operator: Drivers may drive but an operator is a very safe, cost efficient and professional person.

Trailer owners must review operating instructions with operators or employees before allowing them to operate the equipment, and review at least annually thereafter.

The most important device on this equipment is a SAFE operator. It is the operator's responsibility to read and understand ALL Safety and Operating instructions in the manual and to follow them.

Any person who has not read and understood all operating and safety instructions is not qualified to operate the equipment.

Do not modify the equipment in any way. Unauthorized modification may impair the function and/or safety of the equipment and affect trailer life.

The Safety Alert Symbol identifies important safety messages on the BWS trailer and in the manual. When you see the symbol, be alert to the possibility of personal injury or death. Follow the instructions in the safety message.

WARNING and CAUTION with the safety message. The appropriate signal word for each message has been selected using the following guidelines:

DANGER - An immediate specific hazard which WILL result in severe personal injury or death if the proper precautions are not taken.

WARNING - A specific hazard or unsafe practice which COULD result in severe personal injury or death if proper precautions are NOT TAKEN.

CAUTION - Unsafe practices which COULD result in personal injury if proper precautions are NOT TAKEN, or as a reminder of good safety practices.

YOU are responsible for the SAFE operation and maintenance of your trailer. YOU must ensure that you and anyone else who is going to operate, maintain or work around the trailer is familiar with the operating and maintenance procedures and related SAFETY information contained in the operator's manual.

THINK SAFETY! WORK SAFELY!

1.1 OPERATING SAFETY

1. Read and understand the operator's manual and all safety signs before operating, maintaining or adjusting the BWS trailer.
2. Do not allow riders on any part of the trailer during road or highway travel.
3. Keep hands, feet, clothing and hair away from all moving parts.
4. Tie load before moving or transporting trailer.
5. Check tie-downs frequently during transport to prevent shifting or movement of the cargo.
6. Clear the area of all bystanders, especially children, before starting up and operating the truck, trailer or equipment.
7. Make sure that all lights and reflectors required by local highways and transport authorities are in place, clean and can be seen clearly by all overtaking and oncoming traffic.
8. Before disconnecting the tractor from the trailer unit(s) make sure that the tractor and trailer are on level ground and that the trailer park brakes are applied.

1.2 MAINTENANCE SAFETY

1. Read and understand all the information in the operator's manual regarding maintenance, adjustment and operation of any BWS trailer or unit.
2. Stop the engine, remove ignition key and set the park brake before adjusting, servicing or maintaining any part of the trailer unit.

1.3 LOADING SAFETY

1. Do not drop load on trailer in order to prevent damaging the cargo or the trailer.
2. Place concentrated heavy loads over structural beams when loading.
3. Tie load securely before moving or transporting.
4. Check tie-downs frequently when transporting and keep them tight.
5. Do not exceed load concentration and total load carrying specifications for trailer.
6. Install lights or flags on load if it extends beyond deck.
7. Do not side load.

1.4 SAFETY DECAL MAINTENANCE

1. Keep safety decals and signs clean and legible at all times.
2. Replace safety decals and signs that are missing or have become illegible.
3. When ordering replacement parts that display a safety sign or decal, be sure to order the replacement safety sign or decal also.
4. Safety decals or signs are available from your Dealer Parts Department.

1.5 SIGN-OFF FORM

Anyone operating and/or maintaining a BWS trailer must read and clearly understand ALL safety, operating and maintenance information presented in this manual.

Do not operate or allow anyone else to operate this equipment until such information has been reviewed. Review this information annually.

Make these periodic reviews of SAFETY and OPERATION a standard practice for all of your equipment.

A sign-off sheet is provided for your record keeping to show that all personnel who will be operating or maintaining the equipment have read, and understood, the information in the operator's manual and have been instructed in the operation of the equipment.

2.0 SAFETY DECALS

The types of decals used on the equipment are shown below. Responsible practices require you to familiarize yourself with the various Safety Decals, the type of warning and the area, or particular function related to that area that requires your SAFETY AWARENESS.

THINK SAFETY! WORK SAFELY!

REMEMBER

If Safety Decals have been damaged, removed, become illegible or parts are replaced without decals, new decals must be applied. New decals are available from your authorized dealer.

WARNING
DESIGN PERFORMANCE OF THE AIR SYSTEM
REQUIRES A MINIMUM 115 TO 130 PSI
UNINTERRUPTED AIR PRESSURE TO THIS TRAILER

AVERTISSEMENT
LA CONCEPTION DE RENDEMENT DU SYSTÈME D'AIR
NÉCESSITE QUE CETTE SEMI-REMORQUE SOIT
ALIMENTÉE AVEC UNE PRESSION D'AIR
ININTERROMPUE DE 115 A 130 LB/PO2
www.bwstrailers.com

WARNING!
**FAILURE TO RELEASE BRAKES
ON TRACTOR OR TRAILER WHEN
DUMPING MAY RESULT IN
SERIOUS STRUCTURAL DAMAGE
AND POSSIBLY CAUSE INJURY
TO THE OPERATOR**



DAILY MAINTENANCE

- VISUAL INSPECT WHEEL ENDS
- GREASE ALL HINGE POINTS
- VISUALLY INSPECT HINGE POINTS FOR EXCESSIVE WEAR
- CHECK TIRE PRESSURE

WARNING!
**OPERATING THIS MACHINERY
ON UNSTABLE TERRAIN MAY
CAUSE SERIOUS DAMAGE TO
EQUIPMENT AND POSSIBLE
INJURY TO THE OPERATOR**

WARNING!
**AIR SUSPENSION MUST BE
DUMPED PRIOR TO LOADING
AND UNLOADING.
FAILURE TO DO SO MAY RESULT
IN SERIOUS DAMAGE.**
BWS Manufacturing Ltd. #100400

CAUTION
**THIS TRAILER IS
NOT
DESIGNED FOR POINT LOADS**

CAUTION
**IF LANDING GEAR
IS TOUCHING THE GROUND...
USE LOW GEAR**

RAISE TRAILER LOWER TRAILER

LOW GEAR IS IN

**DO NOT WELD, DRILL
OR CUT HOLES
IN MAIN FRAME RAILS**

**SERIOUS DAMAGE
MAY OCCUR**
www.bwstrailers.com

WARNING!

SAFETY ALERT! (1) FOLLOW ALL TORQUE REQUIREMENTS. (2) DO NOT USE ANY COMPONENT WITH VISIBLY WORN OR DAMAGED THREADS. FAILURE TO FOLLOW THESE SAFETY ALERTS CAN LEAD TO LOSS OF VEHICLE CONTROL, PROPERTY DAMAGE, SERIOUS PERSONAL INJURY OR DEATH.

Hutchens Suspension Torque Requirements
9600-9700 Series (Decal Part Number 16086-01 Rev.G)

After an initial break period, approximately 1000 miles, and at least every 4 months periodically thereafter. ALL bolts and nuts should be checked to insure that recommended torque values are being maintained.
Oiled torque values listed are for new fasteners with lubricated threads. It is recommended that new installations be performed with oiled fasteners. For dry threads which have been in service, use the higher torque values which are noted below.

	OILED	DRY
1 1/8 - 7 (9600 / 9700 Rocker Bolt)	590 lb-ft	790 lb-ft
1 1/4 - 7 (9700 Radius Rod Bolt)	540 lb-ft	720 lb-ft
7/8 - 14 (Aide U-Bolts & 9600 Radius Rod Bolt)	350 lb-ft	470 lb-ft
3/4 - 16 (Aide U-Bolts)	310 lb-ft	420 lb-ft
5/8 - 18 (Rocker Rod Clamp Bolt)	130 lb-ft	170 lb-ft
5/8 - 18 (Spring Retainer Bolt)	35 lb-ft	50 lb-ft

Hutchens Industries, Inc., P.O. Box 1427, Springfield, MO 65801-1427 Toll Free 1 (800) 654-8824

RIDEWELL SUSPENSIONS
30,000 LB. CAPACITY
OVERSLUNG/UNDERSLUNG
RAR-240 PSIG SCALE

ESTIMATED SPRING LOAD PER AXLE	AIR SPRING REQUIRED PSIG
30,000#	30
26,500#	60
20,000#	80
13,500#	40
7,000#	20

RIDEWELL CORP.
P.O. Box 4596, Springfield, MO 65808 USA
Ph: 800-641-1122 (417) 834-6565
www.ridewellcorp.com

Estimated values are approximate and include 1,200# for complete axle assembly. Actual values must be verified by certified scales.

WARNING!
**FOR MAX. CUBE LOADED TRAILER THIS
UNIT IS DESIGNED TO OPERATE WITH
FULLY CHARGED AIR BAGS OR SERIOUS
DAMAGE WILL OCCUR!**
www.bwstrailers.com

RIDEWELL SUSPENSIONS
**MONOPIVOT 240 BOLT TORQUE
MINIMUM SPECIFICATIONS**

ECCENTRIC PIVOT BOLT	1,000 FT. LBS. (1350 N.M)
SHOCK BOLT	160 FT. LBS. (220 N.M)
AIR SPRING CONNECTION - 3/4"	50 FT. LBS. (70 N.M)
AIR SPRING CONNECTION - 1/2"	25 FT. LBS. (35 N.M)
BUSHING CLAMP BOLT	150 FT. LBS. (260 N.M)

See Service Manual for Details.

OPERATING PROCEDURES

3.1 BREAK-IN/INSPECTION

Time and distance specify the normal break-in procedure for a BWS trailer:

1. Check slack adjuster function for the first 3 weeks of operation.
2. Check hub oil levels daily for the first 3 weeks of operation.
3. Check tires for proper inflation pressures. Re-torque wheel nuts after 100 km.

3.1.1 500 MILE / 800 KM INSPECTION

After the first 500 miles/800km of service, some "settling in" will have occurred, particularly in the suspension components.

AT THIS TIME:

1. Re-torque all bolts and fasteners paying particular attention to the axle U-bolts, hub studs, upper and lower fifth wheel bolts and the suspension system. Refer to values in the maintenance section when re-torquing.
2. Check tires for proper inflation pressures and rim alignment. Re-torque wheel nuts. Block the axle and spin the wheels. Check for brake drag and wheel bearing adjustment.
3. Check oil levels in hubs. Maintain proper oil level. If any levels are low, check for leaks and repair.
4. Check axle alignment. Refer to maintenance section for procedure.

3.1.2 10,000 MILE / 16,000 KM INSPECTION

1. Check the function and adjustment of the brakes on each axle. No shoes should drag on the drum when the brakes are not applied.
2. Check tire inflation pressures and tread wear. Always match tires with tread wear that is worn to 1/8" in difference. If unusual or excessive tire wear occurs, it indicates something is wrong. Check further to determine the cause and correct it. See tires section for further information.
3. Re-torque all bolts and bolted connections.
4. Visually check all welds and adjacent areas for cracks. Any cracks should be repaired as soon as possible by an authorized BWS dealer.
5. Ensure all suspension hangers and related members are tight and secure.
6. Check axle alignment. Refer to maintenance section for procedure.

3.1.3 20,000 MILE / 32,000 KM INSPECTION

1. Check each brake lining for wear. Replace or adjust as required.
2. Check the axle alignment. Refer to maintenance section for procedure. The operator can then go to the maintenance and inspection schedule on Page 32.

3.2 PRE-OPERATION VEHICLE INSPECTION PROCEDURE

The safe and trouble-free use of a BWS trailer requires the operator to maintain the unit in good operating condition. To assist the operator, a pre-operation checklist is provided that should be followed each time before the trailer is used. Item numbers in Figure 1 correspond to the following "WALK AROUND SEQUENCE"

WALK AROUND SEQUENCE

STEP 1 – TRAILER FRONTAL AREA

1. Air and Electrical Connections
 - a. Verify that glad hands are properly mounted, free of damage, not leaking and not worn.
 - b. Check electrical line receptacle: Ensure that it is properly mounted, free of damage and the plug is adequately seated with safety catch engaged to prevent accidental disconnection.
 - c. Ensure that air and electrical lines are properly secure against tangling, snagging and chafing with sufficient slack for turns.
2. Lights and Reflectors
 - a. Check front trailer clearance and identification lights clean and operating.
 - b. Ensure reflectors present and clean.

STEP 2 - FIFTH WHEEL COUPLING AREA

1. Fifth Wheel (Lower)
 - a. Secure mount to frame.
 - b. No missing or damaged parts.
 - c. No visible space between upper and lower fifth wheel.
 - d. Locking jaws are around the shank and not the head of the kingpin.
 - e. Release lever properly sealed and safety latch lock engaged.
2. Fifth Wheel (Upper)
 - a. Kingpin is not worn, bent or damaged.
3. Sliding Fifth Wheel
 - a. Mechanism not worn, bent, damaged or parts missing.
 - b. Properly lubricated.
 - c. All locking pins present and locked in place.
 - d. If air operated: there should be no air leaks.
 - e. Check the fifth wheel is not so far forward that the tractor frame will strike landing gear during turns.
4. Air and Electrical Lines Visible From This Point
 - a. Ensure lines are properly secured and are free from tangling, snagging, and chaffing.
 - b. Free of damage, oil and grease.

NOTE!

The tractor items, part of North American Walk Around Sequence have been omitted.

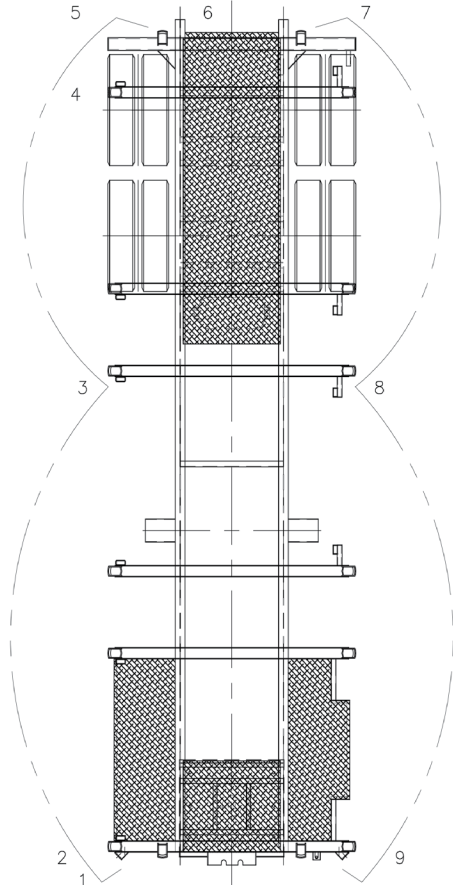

Figure 1

STEP 3 - RIGHT SIDE OF TRAILER AREA

1. Front Trailer Support
 - a. Fully raised, no missing parts, not bent or otherwise damaged.
 - b. Crank handle present and secured (typically on left side).
 - c. If power operated, no air or hydraulic leaks.
2. Spare Tires
 - a. Carrier or rack not damaged.
 - b. Tire and/or wheel securely mounted in the rack.
 - c. Tire and wheel condition adequate. Proper spare tire size, correctly inflated.
3. Lights and Reflectors
 - a. Clearance lights clean, operating and proper color.
 - b. Reflectors clean and proper color.
4. Frame and Body
 - a. Frame and cross members not bent, cracked, damaged or missing.
 - b. Body parts not damaged or missing.
5. Placarding
 - a. Proper identification of trailer load.

STEP 4 - BRAKES

- a. Check condition of brake linings and drums.
- b. Check condition of hoses, lines & valves.
- c. Check slack adjusters.
- d. Check air chamber mounting.
- e. Check spring brakes.
- f. Drain moisture from air tank, close petcock

STEP 5 - RIGHT REAR TRAILER WHEEL AREA

1. Wheels/Axles
 - a. Check condition of wheels and rims. Verify that there are – no cracked or bent rims, broken spacers, studs, clamps or lugs.
 - b. Condition of tires – properly inflated, valve stems not touching wheel rims or brake drums, valve caps in place, no serious cuts, bulges, tread wear or any signs of misalignment and no debris stuck between the tires.
 - c. Tires all same type, e.g. DO NOT mix radial and bias types on the same axle.
 - d. Wheel bearings and hub have no obvious leaking.
 - e. Mud flaps in place and in good condition.
 - f. If equipped with sliding axles check position and alignment, look for damaged, worn or missing parts. Check for locking pins in locking position.
 - g. Ensure that air lines are not cracked, cut, crimped or otherwise damaged and secured against tangling, snagging or chafing.
2. Suspension
 - a. Condition of spring(s), spring hangers, equalizers and U-bolts.
 - b. Axle alignment.
 - c. Condition of torque rod arms and bushings.

STEP 6 - REAR OF TRAILER

1. Lights and Reflectors
 - a. Rear clearance and identification lights – clean, operating and proper color.
 - b. Reflectors are clean and proper color.
 - c. Taillights - clean, operating and proper color.
2. Cargo Securement
 - a. Cargo properly loaded side to side and back to front.
 - b. Check cargo tie-downs and ensure they are tight. National Safety Code Standard 10 Cargo Securement.
 - c. Ensure concentrated load is positioned over structural beams.
 - d. Canvas or tarp (if required) are properly secured to prevent water damage or blockage of either the mirrors or rear lights.
 - e. Check “B” train 5th wheel.

STEP 7- LEFT REAR TRAILER WHEEL AREA AND BRAKES

Check all items as done on right side (step 5).

STEP 8- LEFT SIDE OF TRAILER AREA

Check all items as done on right side (step 3).

STEP 9- TRAILER(S) FUNCTIONAL CHECK (TRACTOR ATTACHED)

1. Check for proper connection of air brake glad hands, and secure contact of electrical connection.
2. Start engine.
3. Build up air pressure in the tractor-trailer systems.
4. Turn on lights and inspect for proper function of:
 - a. Clearance lights.
 - b. Identification lights.
 - c. Turn signals and 4-way flashers.
 - d. Side marker lights.
 - e. Tail lights.
 - f. Stop lights
5. Check the function of brakes.
 - a. Apply service brakes.
 - b. Apply parking brakes.
 - c. Apply accelerator with brakes in emergency to ensure park brake functions.
 - d. Stop engine.
 - i. Release trailer emergency brakes.
 - ii. Apply service brakes.

AIR LOSS SHOULD NOT EXCEED:

3 psi per minute on single vehicles.

4 psi per minute on combination.

IMPORTANT!

Broken or malfunctioning equipment is dangerous and is to be replaced immediately.

3.3 PRE-OPERATION VEHICLE INSPECTION PROCEDURE (TAG TRAILERS)

The safe and trouble-free use of a BWS trailer requires the operator to maintain the unit in good operating condition. To assist the operator, a pre-operation diagram and list is provided. This should be followed each time before the trailer is used (Figure 2).

WALK AROUND SEQUENCE

STEP 1 – TRAILER FRONTAL AREA

1. Air and Electrical Connections
 - a. Verify that glad hands are properly mounted, free of damage, not leaking and not worn.
 - b. Check electrical line receptacle: Ensure that it is properly mounted, free of damage and the plug is adequately seated with safety catch engaged to prevent accidental disconnection.
 - c. Air and electrical lines are properly secured from tangling, snagging and chafing with sufficient slack for turns.
2. Lights and Reflectors
 - a. Front trailer clearance and identification lights clean, operating and proper color (Check before each trip).
 - b. Reflectors clean and proper color.

STEP 2 - COUPLING SYSTEM AREA

1. Pintle Eye (Trailer)
 - a. Verify that the coupling eye is not worn, bent or damaged.
 - b. Verify that the eye mounting bolts are installed properly.
 - c. Verify that the pintle mounting bolts are tight.

STEP 3-9

Refer to previous section.

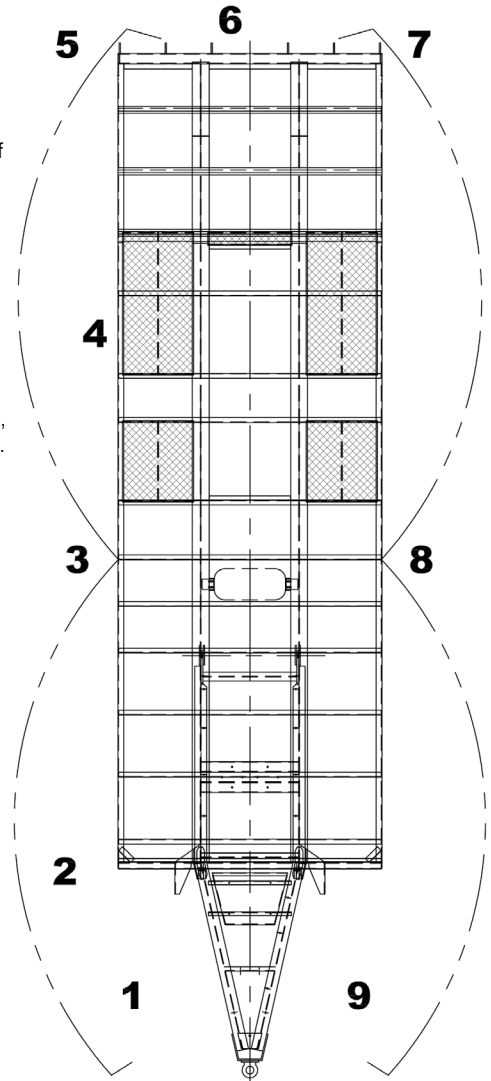

TAG Trailers Only (Figure 2)

3.4 FIFTH WHEEL OPERATING INSTRUCTIONS (FIGURE 3)

1. Failure to read, understand and follow the important information contained herein may result in a hazardous condition or cause a hazardous condition to develop.
2. Relative to the tractor trailer operations, there are other checks, inspections and procedures not listed here which are necessary, prudent and/or required by law. The following is in addition to these, and pertains to the fifth wheel only.
3. Perform these procedures with the area clear of obstacles and other personnel.

3.4.1 COUPLING PROCEDURE

1. Visually inspect the equipment before coupling.
 - Make sure the fifth wheel is properly lubricated, the locks are open and the ramps are tilted down in the proper position.
 - Make sure the mounting of the fifth wheel to the tractor or trailer is in good condition and tight.
2. Back up close to the trailer, centering the kingpin in the cradle of the fifth wheel, STOP.
3. Check to see that the trailer is at the proper height for coupling. The leading edge of the trailer plate should initially contact the fifth wheel top bearing surface behind its pivot axis as the tractor or trailer backs under the trailer. Raise or lower the deck supports as required to obtain this position.
4. Back under the trailer, keeping the trailer kingpin centered in the crotch of the fifth wheel.
5. After picking up the trailer with the fifth wheel, STOP, then continue backing until the fifth wheel locks firmly on the king pin.
6. Back up tight to the kingpin. Pull forward to test the completeness of the coupling as an initial check.
7. Visually check to see that the kingpin is in the fifth wheel locks, ensure that it is not overhanging the fifth wheel or caught in a grease groove. There should be no gap between the trailer plate and the fifth wheel.
8. Connect the light cord and the brake lines and be sure any slack in the lines is supported and the brake lines do not become tangled.
9. If your fifth wheel is equipped with a manual secondary lock, check to see that it is properly engaged.
10. Release air to the deck supports until they retract.
11. Hook air lines and light cord from tractor to trailer.

FIFTH WHEEL

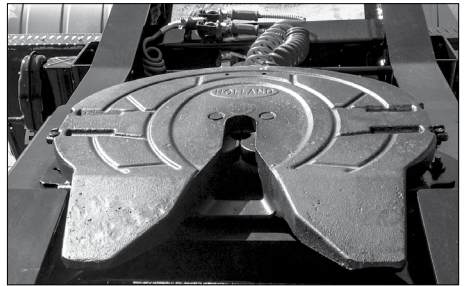

Figure 3



WARNING!

Attempting to couple the trailer at an improper height could result in a false or improper coupling and could cause damage to the fifth wheel or trailer.



WARNING!

If you do not obtain a proper coupling, repeat this sequence. Do not use any fifth wheel which fails to operate properly.



WARNING!

A direct visual inspection is required to assure proper coupling. Several types of improper couplings will pass the initial pull test and the sound is unreliable. Do not take for granted it is properly coupled.

3.4.2 UNCOUPLING PROCEDURE

1. Set the emergency brake on the tractor.
2. Set the trailer brakes with the tractor trailer protection switch.
3. Block the trailer wheels.
4. If the trailer is equipped with air ride suspension, air should be dumped from the air bags after the parking brake is applied and before landing gear is extended.
5. Crank down the landing gear (Figure 4)

6. until they touch the ground and give a few extra turns in low gear. Do not raise the trailer off the fifth wheel.
7. It may be necessary to provide a base for the landing gear in poor conditions if the trailers are loaded without the tractor attached.
8. Fold down or remove the crack handle and place it in the crank handle holder.
9. Disconnect the light cord and brake lines.
10. Unlock the fifth wheel, including the mandatory secondary lock if so equipped. Dump the suspension system if the truck is equipped with an air ride suspension.
11. Release the tractor emergency brake and pull out slowly from under the trailer. Let the trailer slide down the fifth wheel and pick up ramps with minimal impact of the trailer landing gear with the ground.

3.5 LOADING

It is the responsibility of the operator to review and be familiar with the trailer loading capacity specifications and make sure that all loading limitations or restrictions are complied with for each operating jurisdiction. Exceeding the trailer weight specifications can result in damage to the structure. Exceeding the road restrictions is illegal.

- a. Do not drop a load on the trailer. Place it on the floor in a position of equalize load distribution.
- b. Loading without the trailer being coupled to a fifth wheel is not recommended. Dynamic loads encountered during loading can damage the landing gear structure or cause the trailer to nose dive.
- c. Determine the load carrying capacity of your trailer and the proper load position before you start loading.

DECK SUPPORTS

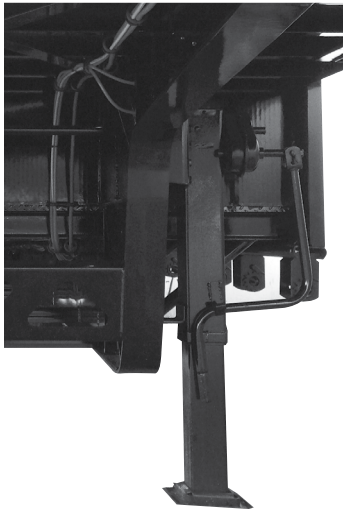

Figure 4

3.5.1 TRAILER

WEIGHT DISTRIBUTION

1. Trailers are designed for uniform load distribution as shown in Figure 5. The load should be distributed equally between the front and the rear of the trailer.
2. Crosswise weights should be equally distributed (Figure 6) . A heavy load should not be placed on one side. This will overload suspensions and tires on that side. Place load so that weight will be equal on rear tires, eliminating possible twisting of the frame and overloading of axle housings and wheel bearings.
3. Loading heavy concentrated loads not occupying full trailer floor area:
 - Do not place heavy concentrated loads on trailer edges.
 - Heavy concentrated loads must be placed on frame rails.

UNIFORM LOAD DISTRIBUTION FRONT TO BACK

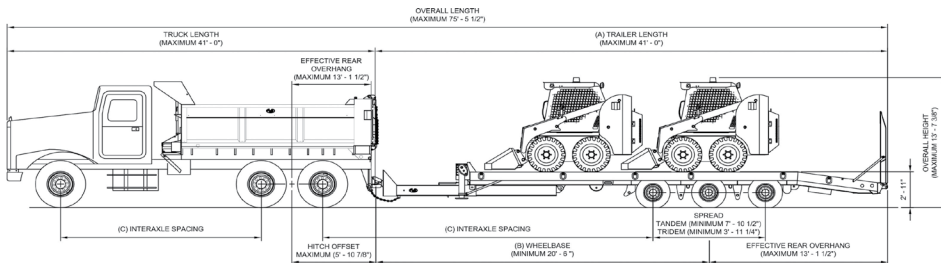

Figure 5

UNIFORM LOAD DISTRIBUTION SIDE TO SIDE

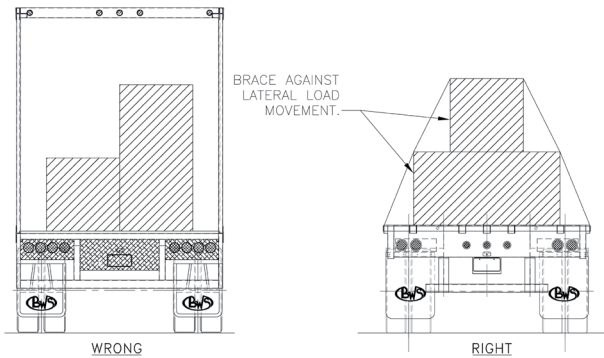

Figure 6

3.5.2 LOAD RESTRAINTS

All loads must be properly secured before moving or transporting the trailer to prevent cargo movement. Attach the load restraints in a crossing pattern to prevent both lateral and longitudinal movement. Do not exceed the working strength of the restraints or the anchor. Check the restraints frequently during transport to ensure they stay tight. If they remain loose, the load can shift or move and lead to an unsafe condition.

Some approved tie-downs include but are not limited to: (Figure 7A & 7B)
See North American Securement Laws.

LOAD RESTRAINTS



Figure 7A



Figure 7B

3.6 TRANSPORTING

After following the preceding instructions, your BWS trailer or unit is ready for transport. It is wise to review operating instructions periodically to refresh your memory. Good operation procedures result in a safe work environment for all.

1. Ensure the trailer is securely attached and locked into position.
2. Ensure the air lines are securely connected and have sufficient slack for turns.
3. Ensure the brakes are properly adjusted and functioning adequately.
4. Ensure the electrical harness is securely attached and all lights and reflectors are clean and in good working order.
5. Ensure that the mud flaps are in good condition to minimize road splash in wet conditions.
6. Always keep the trailer in good mechanical condition.
7. Ensure the cargo is securely tied down.
8. Always keep the trailer in good mechanical condition.
9. Ensure the cargo is securely tied down.

3.6.1 BRAKING GUIDELINES

Safe, reliable and trouble-free operation of your trailer requires that the brakes be maintained in good operating condition. The improper use of brakes by the driver can contribute to shorter brake component life, result in system malfunctions, and cause poor tire wear patterns. The following list summarizes some basic operational guidelines for the driver.

1. Check the function of the brake system before starting a trip.
2. Maintain a safe speed at all times. Slow down for rough, slippery, congested, or winding road conditions.
3. Always provide sufficient vehicle spacing on the road to allow for safe stopping distance.
4. Apply brakes gradually to produce an even deceleration until the vehicle is stopped.
5. Watch traffic patterns ahead. Anticipate pattern changes that could result in an emergency. Apply the brakes gradually in sufficient time to produce a controlled stop.
6. Shift to a lower gear to use engine compression as the retarding force when going down steep grades.
7. Do not apply brakes for a long period of time such as when traveling on a long downgrade. Light intermittent brake application will result in proper vehicle control and keep brakes from overheating.
8. Dry the brakes by applying them several times after going through water.
9. Release the brakes just before going over railroad tracks or in other rough conditions. By allowing the wheels to turn over rough road surfaces, there will be no shock loads to the brake system components and the possibility of flat spotting tires will be reduced.
10. Wet, icy or snow-packed surfaces require special care. Make sure ABS is functioning properly.
11. Use wheel chocks, apply trailer and tractor parking brakes when parking the unit.
12. When trailer-parking brakes are applied with hot drums, it may result in a cracked drum. Allow drums to cool before applying the brakes.
13. Fanning, or repeated on-and-off applications, will use up the system air reserves. This procedure is not recommended with ABS. The wasting of air pressure reserves could result in insufficient air pressure should an emergency occur.
14. Hard or panic stops can overheat the linings and drums. Overheating will cause brake fade. Severe overheating and fade can result in the complete loss of braking capability. Overheating will also substantially reduce the expected life of brake components.

3.6.2 TIRES

When operating the trailer, it is the responsibility of the driver to check the tires frequently. Inflation pressures, wear patterns and matching are critical parameters that must be monitored. The following factors affect tire life:

1. INSPECTION FREQUENCY

Tires should always be checked before the start of a run, twice during the day or every 4 hours, whichever comes first. It is also good practice to check the tires at each rest period during the day. When a driver hears or feels unusual handling characteristics, the first items to check are the tires. Problems found early can help avoid more serious problems later on. A sample of typical abnormal wear patterns are shown in the maintenance section of the tire wear problem before proceeding.

2. INFLATION PRESSURE

Tires should always be operated at specified pressures. The tire is designed to run with the full width of the tread flat on the contact surface. Operating at other than specified pressures will change the tread contact patterns and dramatically shorten tire life. In addition, the tires will run hotter and can lead to blow-outs.

Check tire pressure when the tire is cold. A hot tire can read as much as 20 psi higher than a cold tire. If tires are over inflated, check for poor load distribution, uneven surface contact, over-loading or poor operating conditions. For inflation pressures, refer to manufacturers' specifications.

3. TIRE MATCHING

Do not mix radial and bias-ply tires on the same axle. Their operating characteristics are different and will lead to uneven tire loading, rapid tire wear and adverse handling characteristics. Matching also includes combining tires that have the same amount of tread remaining. A tire with more tread has a larger rolling radius and will have to carry a heavier load. The best performance will be obtained when the rolling radius is within 1/8" for all tires on the axle.

4.0 QUARTER FRAME END DUMP

4.1.1 PRE-OPERATION VEHICLE INSPECTION PROCEDURE

The truck 5th wheel must be locked in a level position.

4.1.2 GENERAL TRAILER COMPONENTS

Completely read, understand and implement the Trailer Pre-operation Vehicle Inspection Procedure.

4.1.3 PIVOT PINS

Inspect all pivot pins (10) to ensure that they are in place correctly. If any of the pins are missing or damaged, do not operate the trailer. Have any damaged or missing parts replaced by a qualified service technician.

Dump Hinges (2)

Suspension Pivot Assembly (4)

Rear Of A Frame Pivot Assembly (2)

Fifth Wheel (1)

Top Of Hydraulic Cylinder (1)

Inspect all Pin lock brackets (10) installed on the pins to ensure they are in place and the bolts are secure (Figure 8B and 8C). Tighten any loose bolts to 25 ft-lbs torque. Replace any missing bolts prior to operating trailer. Refer to dealer for bolt size and specifications.

Inspect all pins to ensure that the locking snap-ring is still in place on end pin opposite the pin lock bracket (Figure 8A). Replace any missing or damaged snap-rings prior to operating trailer. Refer to Dealer for part size and specifications.



Figure 8A



Figure 8B

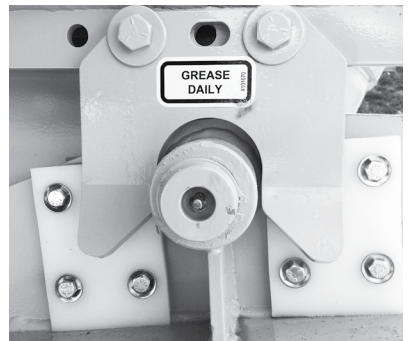

Figure 8C

4.1.4 BOLTED HINGE CONNECTIONS

Inspect bolted connection at dump hinge (2) on rear of body to ensure that all the bolts are still in place and tight (Figure 8A). Torque any loose bolts to 110 ft-lbs. Replace any missing bolts prior to operating trailer. Refer to dealer for bolt size and specifications.

Inspect manual locking latch mechanism on left rear corner of body to ensure that is operating correctly so the tailgate is locked securely by the latch at the rear top left section of the body. Replace any worn or missing parts prior to operation of trailer.

(2) at rear of A Frame pivot assembly where the pivot assembly is bolted to the body (Figure 9). Torque any loose bolts to 110 ft-lbs.

Replace any missing bolts Inspect bolted connection prior to operating trailer. Refer to dealer for bolt size and specifications.

Inspect tailgate pins at rear right to ensure they are in place and locking devices used to secure them are operational. Replace any worn or missing parts prior to operation of trailer.

Note: Some of these parts are not used in all tailgate configurations. Trailers equipped with vertical swing only tailgates will not have the pins and latch mechanism. Follow all applicable safety and operational instructions when using this type of trailer.



Figure 9

4.1.5 TAILGATE AIR CONTROLLED LATCH

Verify that the latch mechanisms (2) located on both bottom sides of the tailgate are fully locked when the tailgate control is set to lock position in cab of truck. Do not operate trailer if locks do not fully engage. Refer to dealer for required service. Verify that latch mechanisms (2) open fully to allow proper operation of tailgate when control is set to open position in cab of truck. Do not operate trailer if locks do not fully engage. Refer to dealer for required service.

4.1.6 ALIGNMENT BRACKETS

Verify that fifth wheel alignment brackets (2) are in place on either side of the body so they will engage the fifth wheel pin support as the dump is lowered (Figure 11). Verify that the UHMW guide plates are in place. Replace any missing or worn parts prior to operating trailer.

Verify that the body alignment brackets are in place on either side of the suspension so they will guide the body into the correct position as it is lowered (Figure 12). Replace any missing or worn parts prior to operating trailer.



Figure 10



Figure 11

4.2 TAILGATE OPERATION

4.2.1 VERTICAL SWING MODE

Tailgate will pivot with the hinge point at the rear body top. Ensure that left manual tailgate latch is locked in the lower position (Figure 13). Locking pin must be in place to ensure safe operation of failure. Injury to personnel and/or damage to equipment could occur if the latch is not locked in the correct position.

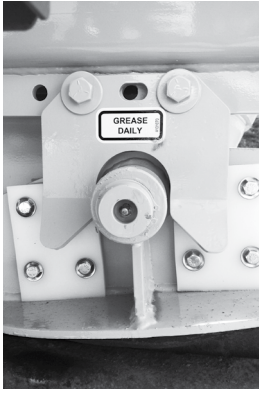

Figure 12



Figure 13



Figure 14

Verify that the locking arm at the top left rear section of the body has securely locked the tailgate vertical pivot bushing in place (Figure 14). If the locking arm does not fully engage the pivot bushing (Figure 15), the linkage rod will need to be adjusted. Refer to dealer for correct adjustment procedure.

Remove lower horizontal pivot pin located on lower right section of tailgate. The tailgate will not operate if this pin is not removed and product damage could result if it is left in place during material dumping. (Figure 16). Store pivot pin in bracket provided on left rear ladder. Use locking pin to ensure the pin stays in the bracket.

Operate the lower pneumatic tailgate latches using the control located in the cab of the truck. These latches will unlock and lock the tailgate as required.

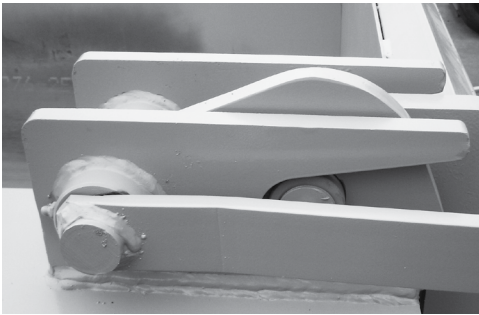

Figure 15



Figure 16

4.2.2 HORIZONTAL SWING MODE

Tailgate will pivot horizontally with the hinge point at the right rear side of the body. Use caution during this operation as the tailgate is a heavy part that could cause injury to personnel if this procedure is not done properly. Ensure that the vehicle is parked on a level surface prior to operating tailgate. Stand clear of area behind trailer where material may fall from trailer body when tailgate is opened.

Verify that lower pivot pin is in place and retaining spring lock is installed (Figure 17). Note If trailer is equipped with optional asphalt apron, this assembly must be removed before operating the door in a horizontal opening mode.

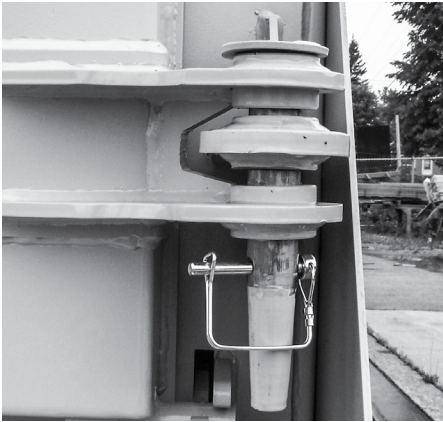

Figure 17

Move Tailgate manual latch to upper location and lock in place with spring pin (Figure 18). This will raise the locking arm to release the vertical pivot bushing on the top left section of the body.



Figure 18

Release pneumatic tailgate latches using the control located in the cab of the truck.

Note: The tailgate will be free to pivot when the latches are released. Ensure that no personnel are near the area as they could be injured by material falling out of trailer body or by the door swinging if the trailer was not positioned correctly on level ground.

Safely guide the tailgate around to the side of the trailer and secure it in this position with the hook mounted on the tailgate and the bracket mounted on the side of the body (Figure 19A & 19B). Take care during this process not allow any part of your body to come between the tailgate and the side of the body to avoid injury. Ensure that the tailgate is securely fastened in place as it could cause injury to personnel or damage to the trailer if it moves on its own during the dumping process.



Figure 19A



Figure 19B

4.2.3 GREASING

After dumping process is complete, manually guide the door back into the closed position. Use caution not to allow any part of your body to come between the door and the rear of the trailer as the door closes because this could result in a serious injury. Swing the door into place and at the same time move the manual latch into the lower position. This will engage the locking arm to secure the vertical pivot bushing in the locked position. Install the spring pin to keep the manual latch in the lower position and the tailgate pivot bushing is locked in place. Engage the pneumatic tailgate latches to lock the tailgate in the closed position.

Note: All three of these operations must be completed before the tailgate is securely locked and it is safe to operate the trailer. Refer to dealer if the latches do not operate properly.

4.3 GENERAL TRAILER COMPONENTS

Completely read, understand and apply the Trailer Service and Maintenance Procedure detailed in the BWS General Operator's Manual. Ensure that all operators of the trailers are familiar with the operation and maintenance and related safety information contained in the operator's manual.

4.4 MAIN PIVOT BUSHINGS

This trailer is equipped with zero maintenance Dry Slide self-lubricating bushings in all the main pivot bushings. This includes the dump hinges (2), suspension frame assembly (4), A frame assembly (4), Tailgate pivot bushing (2) (Figure 20). These bushings should be inspected periodically to ensure that due to excessive wear, movement is not allowed between the pin and metal bushing. If this occurs refer to dealer for bushing replacement.

Note: Grease fittings have been added all the Main Pivot Pins except the one installed in the top of the Lift Cylinder.

4.5 GREASING

The following items should be greased on a daily basis (10 hours operation):

Bottom or lift cylinder (fitting located on front of fifth wheel plate)

Tailgate Pivot Bushing Lock 2 Fittings

Tailgate right upper hinge bushings 3 Fittings

Main Pivot pins 10 Fittings (Fitting on both ends of Fifth Wheel Pin)

Tailgate pneumatic lock shaft bushing (3 Fittings). Access the two outside bushings by removing the rubber covers located on both sides in tread plate access cover. The centre fitting is located at the rear and can be reached between the bottom of the body and the top rear of the suspension assembly.

4.6 HYDRAULIC LIFT CYLINDER

The trailer is equipped with a heavy duty multi-stage hydraulic lift cylinder (Figure 20). The lower pivot pin requires greasing daily (10 hours operation) through a grease hose fitting located on the fifth wheel assembly. The upper pivot pin is equipped with a zero maintenance spherical bearing that does not require periodic greasing. Daily inspection of these pivot location and the entire cylinder is required to detect any damage that may occur. Do not operate the dump function of the trailer if there is any damage to the cylinder as personnel injury or equipment damage could occur. Refer to dealer for any required service if damage is detected.

Inspect hydraulic fittings and hoses daily (10 hour operation) for any leaking of hydraulic fluid or signs of wear/damage. Do not operate the dump function of the trailer if there is any damage to the cylinder as personnel injury or equipment damage could occur. Tighten any loose fittings found and replace any damaged hoses. Refer to dealer for any required service if damage is detected.

4.7 LOADING

Ensure that the trailer is loaded in a safe manner that will not pose a risk to personnel in the area or to motorists that will share the road during transit. Any material loaded on the trailer must be securely constrained by the trailer structure or tarp system to avoid causing injuries or damaging vehicles during transit.

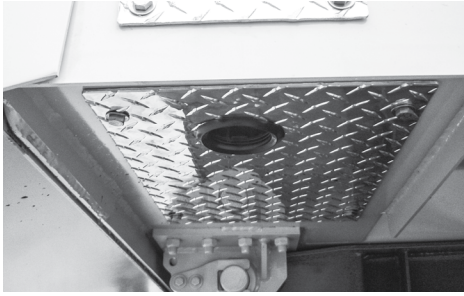

Figure 20

Do not overload the trailer past its safe limits detailed on the Vehicle Identification Number Tag (VIN Tag) mounted on the trailer and all legal requirements of the jurisdiction the trailer is operated in. Overloading is a dangerous condition and can lead to instability, tip-overs and damage to the trailer as well as injury to personnel.

4.8 DUMP OPERATION

Note: Operation of dump function can create dangerous conditions for the operator and personnel in the area if correct procedures are not followed and extreme caution taken during the entire process. All personnel in the area should be warned to stay well clear of the area around the truck and trailer during the dumping process. The operator should stay in the cab of the truck during the complete raising and lowering process.

The tailgate must be unlocked prior to elevating the body to prevent material building up against it and causing forces on the body structure that could cause instability or damage.

The trailer is equipped with a solenoid operated air valve that will automatically dump the air in the trailer suspension system when the tailgate is unlocked. This is a safety feature to ensure maximum stability for the trailer during the dumping process. If the suspension does not lower, do not continue with dump process. Refer to dealer for any required service.

The area the dump trailer is operated on must be solid and level. Raising the dump while located on sloping or soft surfaces can result in instability and possibly result in tip over or damage to the trailer structure.

The dump trailer should not be raised in windy conditions that could result in instability and possibly result in tip over or damage to the trailer structure. In moderate wind conditions line the trailer up with the wind direction to reduce wind force on the side of the body during dumping.

Verify that there are no overhead obstructions such as power lines that the dump body will come in contact with during the dump process. Any such hazard can pose a serious chance of injury or equipment damage.

Ensure that the truck and trailer unit form a straight line during the dumping process. The connection of the fifth wheel to the truck resists side loading and adds stability to the unit. When the truck is not aligned with the trailer this results in less stability for the entire unit. The fifth wheel must be locked in the level position during the dumping and hauling process.

When safe conditions for dumping and hauling have been achieved the operator will engage the hydraulic controls in the cab of the truck to supply hydraulic pressure to the lift cylinder. Make sure the parking brakes are off on the truck. Fast idle engine speed is adequate to supply the correct hydraulic flow to the cylinder. The operator shall stop raising the body and immediately lower it if any indication occurs that the unit is tipping, the load has become hung in the body or any other condition that could lead to instability or damage.

When the material has been discharged from the body, the hydraulic control will be used to completely lower the body. Do not move the trailer with the dump body even partially raised as this can lead to an unstable condition or damage to the trailer structure as well as the hydraulic cylinder and/or truck hydraulic system.

Ensure that the tailgate pneumatic latch is fully engaged and the tailgate is completely closed immediately after dumping to avoid possible discharge of any residual material in the body as this may prove to be a danger to personnel in the area or to motorists. The air suspension will reinflate at this point.

4.9 DECALS

The following decals are mounted on the front of the trailer and detail important operational and safety details (Figure 21). Ensure that the operator is familiar with and follows the instructions contained in them. Follow the safety decal instructions detailed in the general trailer manual.

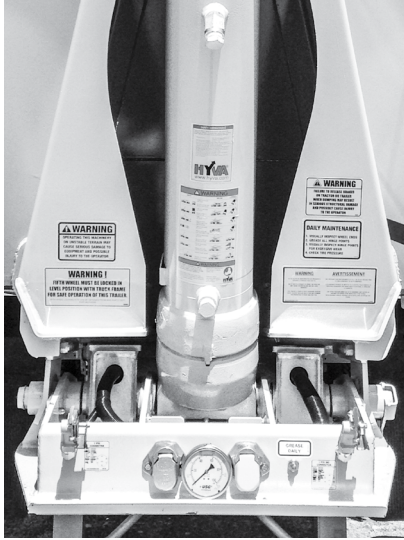

Figure 21

4.10 AIR SYSTEM

Refer to section 7.0 for Air Schematics. Pages 67-68

4.11 TARP

Tarp should be used to prevent commodities such as sand, gravel, rubbish, etc. from damaging other vehicles following the trailer.

Refer to Tarp Manufacturers supplemental manual for installation, operation and maintenance information.

5.0 EQUIPMENT & TAG TRAILER

REAR AIR RAMP OPERATION

Safe loading and unloading areas should be clear of over head and ground level hazards. Identify your trailer load rating. Insure trailer and air and electrical cables are connected to the tow vehicle.

1. Never load or unload a detached trailer always insure trailer and air and electrical cables are connected to tow vehicle.
2. Park trailer and tow vehicle on firm level ground insure brakes are applied. Insure ramp lowering area is clear. Remove ramp securing chains.
3. Locate ramp control lever (Figure 22) when activated, the ramp air will be released and the ramps will lower (Figure 23). There may be a delay in ramp movement to insure ramp lowering area is clear until ramps are lowered to ground level.
 - On a paver trailer (ETP) this will release both the suspension and the ramp air to lower position.

To raise supply air to trailer: reverse procedure.



Figure 22

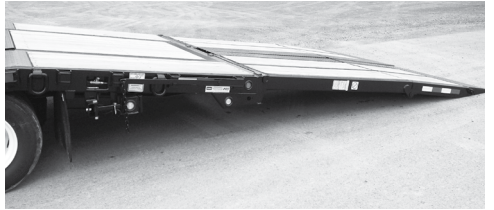

Figure 23

5.1 GOOSENECK UPPER DECK AIR RAMP OPERATION

1. Locate air control box located under gooseneck deck on driver's side of trailer (Figure 24). Open control box and identify lever to raise upper deck ramp. Activate upper deck ramp lever and ramp will rise to a preset height.
2. The upper deck air ramp (depending on length) may have two supports. One support is located in the kick face of the deck; the other is located under the deck ramp. The kick face deck ramp support is held in place by a securing pin (Figure 25). Pull this pin and tilt ramp support towards the rear of the trailer. The second support is located on both sides of the trailer under the deck ramp and is lifted and dropped into position. Ensure the ramp lowering area is clear and then lower deck air ramp onto supports.

To lower supply air to trailer: reverse procedure.

NEVER DRIVE ON RAMP WITH AIR CELL INFLATED.

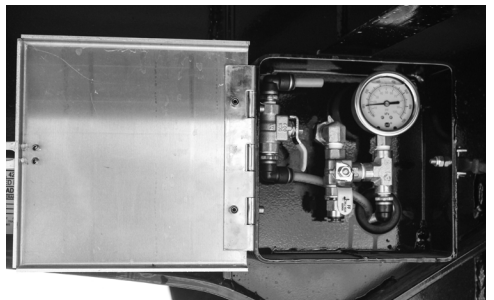

Figure 24



Figure 25

5.2 HYDRAULIC AND ELECTRIC WINCH OPERATION

1. Use all safety precautions and procedures when operating the winch. (Figure 26)
2. Read the winch operational manual supplied with the trailer before operating the winch.
3. The winch may be located on the upper deck or in the kick area of the trailer (Figure 27A & 27B).
4. The winch is controlled by an electric or manual control (Figure 28A & 28B). The Manual control is located under the upper deck on the driver side of the trailer.
5. The hydraulic and electric winch will have a freewheeling spool lever on the winch (Figure 29).

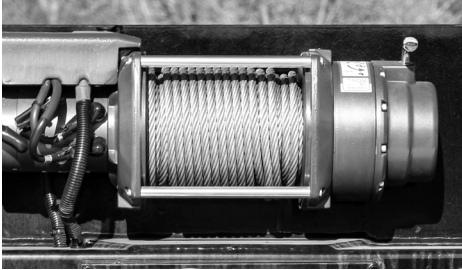

Figure 26

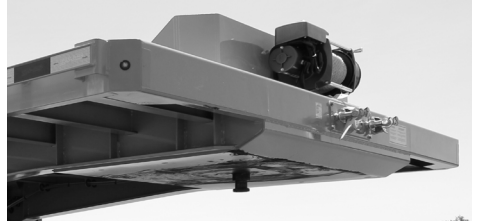

Figure 27A



Figure 27B



Figure 28A

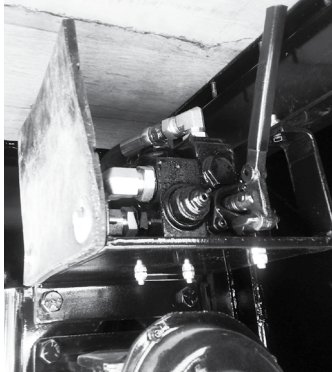

Figure 28B



Figure 29

6.0 MAINTENANCE AND INSPECTION

The safe and efficient operation of your BWS trailer will depend a great deal on your diligence in following the maintenance and adjustment procedures outlined in this section. If you follow these recommendations your trailer will work to its full potential. With adequate attention to regular and preventative maintenance your costs can be reduced significantly.

The various components and systems of your BWS trailer, which will require daily and/or periodic inspections, maintenance and adjustments are presented in this section.

MAINTENANCE SAFETY

1. Set the park brake. Stop engine and remove ignition key before adjusting, servicing or maintaining any components on a trailer unit.
2. Clear the area of bystanders, especially children, when carrying out any maintenance or making adjustments on the system or other components.
3. Keep hands, feet, clothing and hair away from moving and/or rotating parts.

THINK SAFETY! WORK SAFELY!

MAINTENANCE AND INSPECTION SUMMARY

COMPONENT	FREQUENCY	INSPECTION
King Pin	30,000 mile/50,000 km or every 3 months	Kingpin wear and no damage to anchoring
Fifth wheel	30,000 mile/50,000 km or every 3 months	Hardware tight and kingpin lock clearance
Wheel Bearing	25,000 mile/40,000 km or every 3 months	Remove wheel for seal leaks, end play, bearing condition and cleanliness
Hub Oil	Daily	Check oil level
Oil Seals	Daily	Check for leaks and replace seals when leaks occur or wheel removed
Brakes	25,000 mile/40,000 km	Check lining wear. Check brake adjustments.
	1000,000 mile/150,000 km	Re-line as required
Wheels	Daily	Check for wobbles, cracked or bent rims and for loose, missing, broken stripped or otherwise ineffective fasteners.
Tires	Daily	Tire pressure Wear patterns

COMPONENT	FREQUENCY	INSPECTION
Axles	As required	Alignment to chassis
SUSPENSION		
Air Ride Suspension	Daily, also see section 4.8	Air leakage Hardware tightness Mechanical Height check
AIR SYSTEM		
Relay Emergency Value	Every 3 to 6 months	Perform operating and leakage tests
Glad Hands	Daily	Check for cracks, worn or damaged components.
Spring Brake Value	Annually or 100,000 mile/150,000 km	Perform operating and leakage tests
Relay Value	Annually or 100,000 mile/150,000 km	Perform operating and leakage tests
Reservoir	Daily Every 6 months	Drain air tanks Integral check valve function
Air Lines / Hoses	Daily	Check for leaks, chafing, kinking or other mechanical damage
Electrical System	Daily	Check for burned out bulbs and loose connections

6.1 KING PIN AND UPPER COUPLER

Inspect the kingpin and its structure on the trailer at regular intervals to be sure that they have not suffered damage or undue wear. The kingpin should not be bent.

The kingpin should be checked for excessive wear, looseness, chipped areas or cracks. Any kingpin bent or showing the above defects should be replaced or repaired at once.

Inspect the upper coupler assembly for any excessive bowing or cracks. Ensure the entire assembly is safely secured to the trailer by checking the condition of the welds, bolts or rivets, as used in the original construction (Figure 30).



WARNING!

Do not attempt to build up a worn kingpin by welding. The heat of the weld may weaken the special steel used to make the component. Work must be done by an authorized service technician only.

6.2 AXLES

6.2.1 SUGGESTED PREVENTATIVE MAINTENANCE SCHEDULE

1. 18,000 Mile/30,000 km to 24,000 Mile/40,000 km
 - Check brake lining wear and re-line as required.
 - Check brake adjustments and inspect roller, roller shafts, anchor pins and bushings.
 - Inspect brake actuator, camshaft, camshaft bushings, camshaft brackets and camshaft bracket bushings for any wear. Lubricate brake actuating components.
2. 60,000 Mile/100,000 km or at Time of Brake Reline
 - Overhaul and lubricate all brake actuating components.
 - Check all brake chambers.
 - Replace oil in wheel bearings.
3. 100,000 Mile/150,000 km or Min. of Twice a Year
 - Inspect wheel bearings. Check all seals for signs of wear.
4.
 - Retorque suspension pivot bolts and torque rod U-bolts.

6.2.2 AXLE ALIGNMENT

Improper axle alignment with the vehicle frame or chassis will cause excessive tire wear and vehicle dog-tracking. Proper axle alignment is a vital part of your operation (maintenance) and should be checked on a regular basis.

Each trailer is checked for correct alignment before it leaves the factory, but settlement of suspension may necessitate realignment after first 500 miles / 800 km.

The kingpin has a dead-center mark on the bottom side. To ensure proper alignment, a steel tape measure should be run from the center part of the kingpin to an identical location on either side of the front axle.

A small rigid hook in the shape of a question mark made of $\frac{1}{4}$ " bar stock will facilitate this alignment inspection. A steel tape can be attached to the end and this tool hooked over the kingpin. Figure 30 shows another example of a device used for alignment purposes.

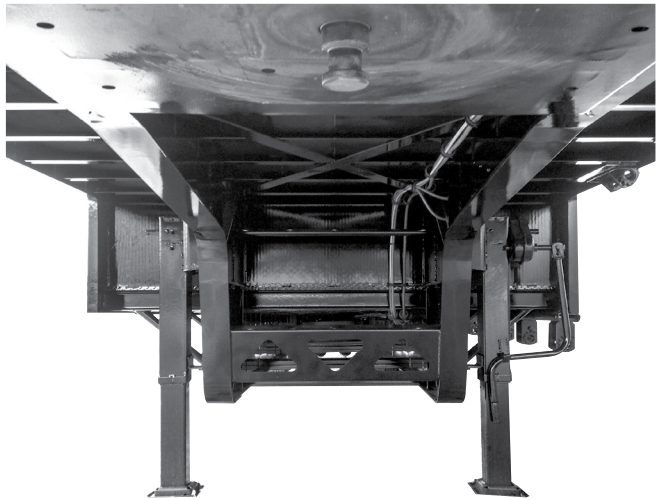

Figure 30

PROCEDURE:

- a. Roll the vehicle back and forth over a level floor a few times to permit the connecting linkage to properly position itself and to center front and rear wheel track.
- b. Center the vehicle across its transverse and longitudinal sections.
- c. Measure the distances "C" and "D" (Figure 31) from the Kingpin to forward axle. These distances must be within 1/8" (3.2 mm) of each other.
- e. Measure the distances "A" and "B" (Figure 32) between the front and rear tandem axles.

These distances must be within 1/8" (1.6 mm) of each other.



Figure 31

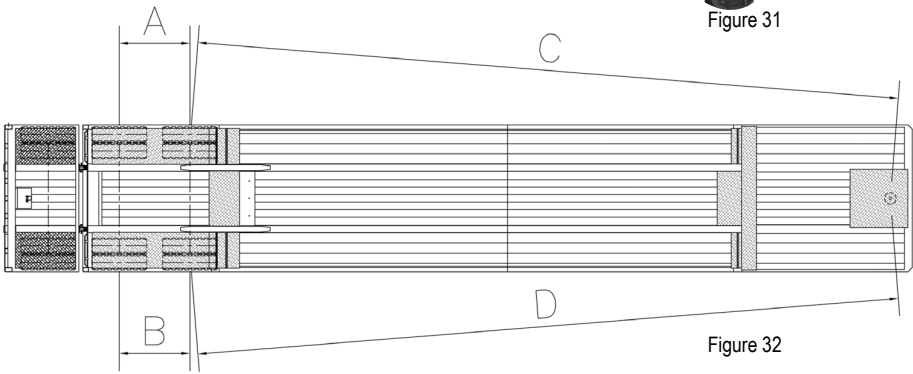

Figure 32

If any of these measurements do not fall within the stated limit, the vehicle suspension should be thoroughly inspected for loose, worn or broken connecting and supporting parts. Adjustments in the suspension and the replacement of broken or worn parts should be made to bring the axles into alignment.

The limits of 1/16" and 1/8" appear very small in comparison to the overall dimensions of the vehicle, but they are recognized as the maximum permissible variation. The relatively small size of these limits make it important that measurements be accurate.

Failure to keep the axles properly aligned may cause tire scrub and suspension component strain.



IMPORTANT!

Replace and repair components as required.



CAUTION!

Insufficient mounting torque can cause wheel shimmy, resulting in damage to parts and extreme tire wear. Excessive mounting torque can cause studs and cap nuts to break and discs to crack in stud hole area.

6.2.3 WHEEL HUBS

Your trailer may be equipped with either steel or aluminum wheels. Check for damaged (bent) and loose wheels, studs, bolts and nuts regularly.

The following procedure is to be used when mounting Hub-piloted Wheels (Disc Wheels) to an axle:

1. Mount both wheels and snug up nuts in sequence shown (Figure 33A & 33B).
2. Torque in the sequence shown to proper torque level.
3. Recommended torque 450-500 ft.-lbs. (Torques are for clean dry threads.)
4. Check tires and wheels for proper seating and alignment.

The wheels should be retorqued after running for 50 to 100 miles, whenever they have been removed for maintenance, and when they leave the factory.

The main type of wheel being used on trailers in the commercial trucking industry today is as follows (Figure 34):



CAUTION!

Nuts must be kept tight by retorquing on a routine basis and by using the proper torque sequence. Loose nuts could result in loose wheel or premature wheel failure. This can result in an accident or injury.

HUB PILOTED DISC WHEELS:

1. Known as "Motor" wheels or "Unimount" wheels.
2. Have straight through bolt holes, no ball seats.
3. Center large hole of wheel onto pilot guides built on hub.
4. One nut per stud fastens wheels in place.
5. Clamped together with two piece flange nuts and spinning washers.
6. Right hand threads only for left and right sides of the trailer.

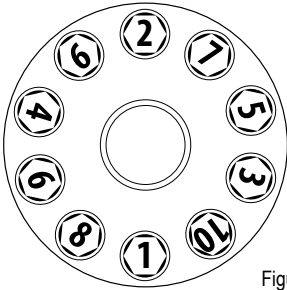

Figure 33A

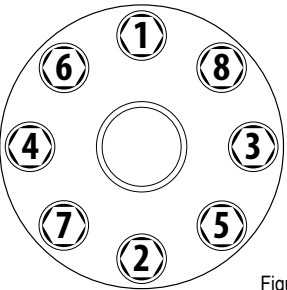

Figure 33B

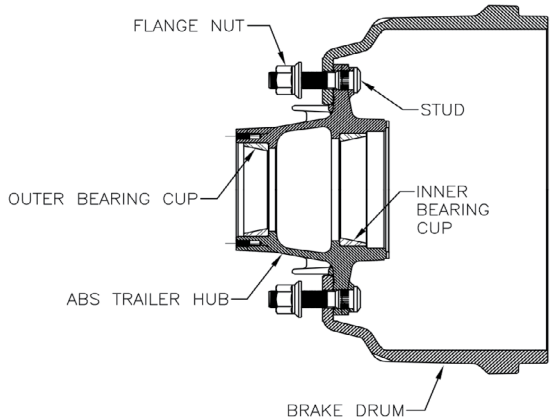

Figure 34

WHEEL BEARING / AXLE DIAGRAM (FIGURE 35)

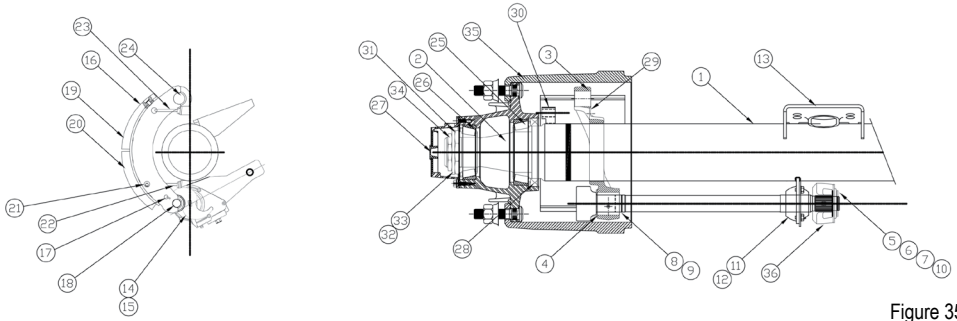

Figure 35

WHEEL BEARINGS PART BREAK DOWN

ITEM	DESCRIPTION	QTY			
1.	TUBE - 0.625 WALL	2	18.	CAM ROLLER	4
2.	SPINDLE - 0.625 WALL	2	19.	BRAKE LINING	8
3.	SPIDER	2	20.	RIVET	80
4.	WASHER - 1 5/8" CAM	2	21.	SPRING RETAINER	4
5.	WASHER - SPLINE END	8	22.	SPRING - RETURN	2
6.	WASHER - SPLINE END	2	23.	SPRING - TENSION	4
7.	WASHER - SPLINE END	4	24.	ANCHOR PIN	4
8.	WASHER - 1 5/8" SPIDER END	2	25.	BEARING - INNER	2
9.	SNAP RING - SPIDER END	2	26.	BEARING - OUTER	2
10.	SNAP RING - SLACK END	2	27.	HUB CAP	2
11.	CAM BRACKET - LH	1	28.	SEAL	2
12.	CAM BRACKET - RH	1	29.	RUBBER GROMMET	2
13.	AIR CHAMBER BRACKET	2	30.	ABS BLOCK	2
14.	CAM - LH	1	31.	SPINDLE NUT - INNER	2
15.	CAM - RH	1	32.	LOCK WASHER	2
16.	12.25 FC BRAKE SHOE	4	33.	STAR WASHER	2
17.	ROLLER RETAINER	4	34.	SPINDLE NUT - OUTER	2
			35.	HUB AND DRUM	1
			36.	AUTO SLACK	2

6.2.4 BEARING ADJUSTMENT PROCEDURE

TMC's Wheel End task force (The Maintenance Council task force on tractor-trailer communications) developed the following bearing adjustment recommendations. It represents the combined input of manufacturers of wheel end components.

STEP 1 BEARING LUBRICATION

Lubricate the wheel bearing with clean lubricant of the same type, as used in the axle sump or hub assembly.

STEP 2

Initial Adjusting Nut Torque Adjustment (While Rotating the Wheel) Tighten the adjusting nut to a torque of 200 ft.lbs.

STEP 3 INITIAL BACK-OFF

Back the adjusting nut off one full turn.

STEP 4 FINAL ADJUSTING NUT TORQUE

Tighten the adjusting nut to a final torque of 100 ft.lbs while rotating the wheel.

STEP 5 FINAL BACK-OFF

Back the adjusting nut off 1/8 to 1/4 turn (app. 0.003 inches)

Note: For self-locking nut systems consult manufacturers' specifications. BWS assumes no responsibility for bearing warranty.

Acceptable end play is .001"-.005" As measured with a dial indicator.

Note: Loose wheel bearings are the major cause of seal leakage. Be sure bearing tolerance is correct.

6.2.5 BEARING ADJUSTMENT

Bearings must be correctly adjusted and properly lubricated to achieve maximum bearing life and to prevent damage to wheels, axles, and possibly the trailer. The bearings should be lubricated at regular intervals, depending on vehicle speeds, loads and general operating conditions. Changes of wheel bearing lubricants are recommended every 20,000 – 25,000 miles, or twice a year (Spring & Fall)

Remove wheel assembly and bearing cones. Clean all old lube from hub of wheel bearings & hubcap with a good grade commercial cleaner and a stiff brush, not steel. DO NOT use gasoline or air hose in cleaning operation. Avoid spinning cone while cleaning.

Allow the cleaned parts to dry and wipe them up with a clean, absorbent cloth or paper towel. Clean all tools used in the service operation.

Note: Grease will not adhere to a surface that is wet with solvent because the solvent may dilute the lubricant.

Cleanliness is most important. Contamination may damage the bearing components.

Inspect seals and seal spring surfaces, bearing cups and bearing cones for indications of wear or damage. Handle all parts carefully during inspection and packaging so the cage will not be bent or the rollers and cone damaged.

Place bearing cones in cups and check for proper fit, and proper number.

Oil Lubricated Bearings – Use a gear type oil SAE-90 and spread a light coat of oil on all parts before assembly.

To prevent "Hot" bearings and provide for maximum load carrying capacity, bearings should be kept free of "slack" and "play". For positive close adjustment, a torque wrench should be used to tighten the bearing to the manufacturers' specifications.

Note: It is recommended to replace axle seals each time wheel ends are serviced.

The following procedure will provide for satisfactory bearing adjustment when the torque method is not feasible. It should be noted that whenever wheels, hubs and drums are removed for any purpose, the bearings will require re-adjustment.

With the wheel raised off the ground and the component parts on the spindle, the inner spindle nut should be tightened until there is no "slack" or "play" in the bearings. The inner nut should then be backed-off approximately one-half turn. The lock (thrust) washer is then placed in position. Next, the outer spindle nut is tightened against the washer.

Once the procedure is completed, the bearings should be given a final check for any "play". This condition can be corrected by progressive tightening of the inner nut, followed by a readjustment of the lock washer and outer nut.

NOTE: SPINDLE NUT WRENCHES FOR THE VARIOUS AXLE MODELS CAN BE PURCHASED FROM OUR PARTS DEPARTMENT.

6.3 GREASE RETAINERS / OIL SEALS

6.3.1 RING AND SEAL TYPE (OIL) MAINTENANCE

Whenever the wheels must be removed for any reason, the seals should be replaced.

6.3.2 RING AND SEAL TYPE (OIL) REPLACEMENT

Remove the seal from the hub by tapping on the face of the bearing cone. Care should be taken to avoid bending the cone cage or nicking the cone rollers.

If the axle ring is found to be defective, it can be removed by carefully and lightly tapping the ring all around with a ball peen hammer. Extreme care must be exercised to avoid cutting through the ring and damaging the spindle collar. After properly tapping the seal, it should expand so as to be removed by hand. Do not try to force the ring by hitting it from the axle bar side. There is no collar or lip on this side of the ring sufficient to prevent spindle damage.

1. To install the new ring and seal, it is mandatory that the seal manufacturers' recommended tool be used.
2. Prior to installing the new ring, the spindle should be clean and free from chips, burrs, etc.
3. Apply a thin coating of No. 2 sealer to the spindle axle ring collar.
4. Using the proper tool, install the ring on the spindle. (See manufacturers' recommendations for the proper position on the ring).
5. Apply No. 2 sealer to the seat's outer diameter.
6. Using the proper tool, press the seal into the hub until it is properly seated. (Proper seating specifications are available from the seal manufacturer).
7. Inspect the installation to assure that the seal components have bottomed evenly and are in the proper position.

6.4 SUSPENSION SYSTEM (AIR)

The axles are attached to and carried by the suspension system. The BWS trailer uses an air ride suspension system.

Each must be kept tight and in good working order to obtain maximum performance and life. The following are suspension service and maintenance procedures to use:

6.4.1 INSPECTION

1. FREQUENCY

- a. During pre-delivery inspection.
- b. After first 500 miles / 800 km of operation.

2. ACTION

- Check that all fasteners are tightened to their specific torque (Pages 40 & 41).
- Check for damaged or broken components.
- Check all suspension system and axle welds or cracks.
- Evaluate tire wear patterns. Use the wear patterns as a guide to determine if maintenance or adjustments are required on the suspension system.
- Check the alignment of the axles.
- Ensure air pressure is being maintained at a pressure greater than 65 p.s.i.

RIDEWELL BOLT TORQUE SPECIFICATION CHART

Bolt Diameter (in.)	Lubricated Threads	
	Torque (Imp.)	Torque (SI)
1 1/2	1,100 ft.lbs.	1,490 N-m
1 1/4	1,000 ft.lbs.	1,350 N-m
1 1/8	500 ft.lbs.	680 N-m
1	360 ft.lbs.	490 N-m
1	460 ft.lbs.	625 N-m
7/8	350 ft.lbs.	475 N-m
3/4	160 ft.lbs.	220 N-m
3/4	190 ft.lbs.	260 N-m
5/8	100 ft.lbs.	135 N-m
3/4	50 ft.lbs.	70 N-m
1/2	25 ft.lbs.	35 N-m



IMPORTANT!

Replace and repair components as required.

RIDEWELL AIR RIDE TORQUE SPECIFICATION CHART

SUSPENSION BOLT TORQUE - MINIMUM SPECIFICATIONS		
LOCATION	TORQUE (IMP.)	TORQUE (SI)
Eccentric Pivot Bolt	1,000 ft.lbs.	1,350 N-m
Shock Bolt	160 ft.lbs.	220 N-m
Air Spring Connection - 3/4"	50 ft.lbs.	70 N-m
Air Spring Connection - 1/2"	25 ft.lbs.	35 N-m
Bushing Clamp Bolt	190 ft.lbs.	260 N-m

6.5 SUSPENSION SYSTEM

The axles are attached to and carried by the suspension system. BWS trailers use either a mechanical or air ride suspension system depending on the specifications. Each must be kept tight and in good working order to obtain maximum performance and life. Review the section that applies to your trailer to familiarize yourself with the service and maintenance procedures.

1. FREQUENCY

- a. During pre-delivery inspection.
- b. After first 500 miles (800 km) of operation.
- c. Periodically.

2. ACTION

- Check that all fasteners are tightened to their specific torque.
- Check for damaged or broken components.
- Check all suspension system for axle wear or cracks.

- Evaluate tire wear patterns. Use the wear patterns as a guide to determine if maintenance or adjustments are required on the suspension system.
- Check the alignment of axles.

6.5.1 MECHANICAL SUSPENSION

- Check all bolts and clamps for tightness.
- Check spring rollers, pads and bushings for wear.
- Check torque arm bushing and torque arm wear.
- Check clamps and bolts.
- Check wheel (axle) alignment.

6.5.2 HUTCH SUSPENSION SYSTEM

Check the torque on the U-bolt nuts by alternately wrenching opposing corners of the clamp assembly. Carefully inspect the spring and the axle clamp components, and replace if excessive wear or cracking is present. (Figure 35)

! WARNING!

Axle restraint devices are a maintenance item. Failure to replace broken restraints will result in other suspension component failures. Components damaged by over extending the suspension will not be covered by warranty.

! IMPORTANT!

For trailers that have been in use for several months, use the dry torque requirements when checking fastener tightness.

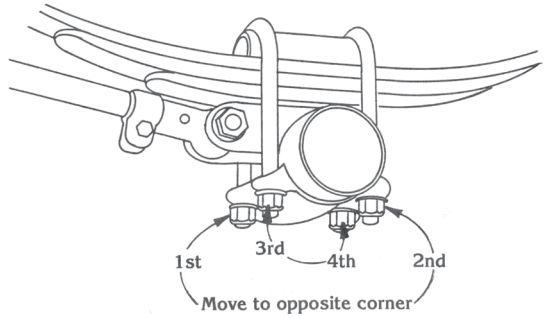

Figure 35

COMPONENT		OILED		TORQUE	DRY	
		N.M	FT. LBS		N.M	FT. LBS.
'U' Bolt	7/8"	475	350		640	470
	Torque Arm Bolts	3/4"	425		580	420
Rocker Bolts	1 1/8"	800	590		1075	790
	1"	735	542		980	720
	3/4"	800	590		1075	790
	5/8"	170	125		230	170
	1/2"	90	65		115	85
Spring Retainer Bolt	5/8"	48	35		70	50
	1/2"	90	65	115	85	

6.5.3 RADIUS RODS

The 1" - 14 UNF radius rod attachment bolt should be tightened to 720 ft.-lbs. of torque. The 1/2" - 20 UNF torque arm clamp bolt should be tightened to 85 ft. lbs of torque. If excessive bushing wear is observed, then the radius rod bushing and bolt must be replaced. Failure to replace the radius rod bushing will result in damage to the hanger, spring seat and/or the radius. (Figure 36)

6.5.4 ROCKER BUSHINGS AND HANGERS

- Check the torque on the rocker bushing clamp bolts and spring retainer bolts.
- Visually check conditions of the rockers and bushings.
- and replace if excessive wear is evident.
- Carefully inspect the hangers and the hanger wear pads and replace if wearing thin. (Figure 37)

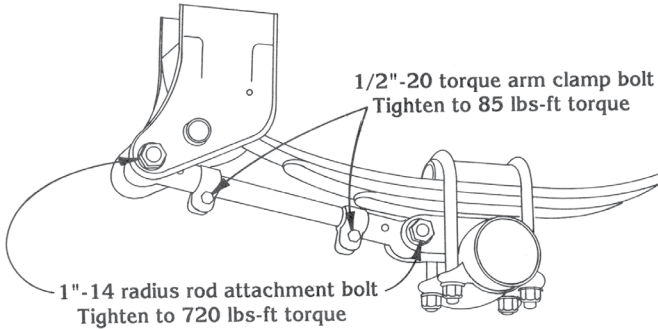

Figure 36

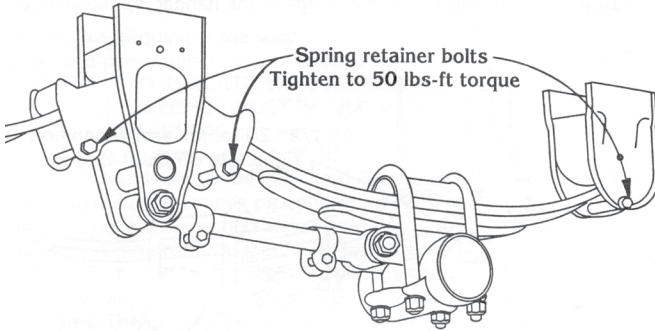

Figure 37

6.6 AIR-RIDE SUSPENSION (FIGURE 38)

Pre-operation Inspection - Before Vehicle is put in Service

- Inspect all welds at hanger to frame connections.
- Inspect for proper installation of cross member between hangers.
- Inspect axle alignment to kingpin (Figure 31)
- Check automatic air control valve and all line and fitting connections.
- Inspect air springs with 65 p.s.i. supply air or greater on a level surface for equal pressure and clearance.
- Inspect for proper mounting height.
- Inspect pivot bolts as per suspension manufactures specifications.

1. DAILY INSPECTION

Visually inspect trailer to be sure it is level and that suspension ride height is correct. Check for loose or broken parts.

2. ROUTINE MAINTENANCE

30 days

- Check clearance around moving parts. Correct signs of interference.
- Check Axle, weld and bolt connections. Correct signs of security and wear.

60 days - Check all welds.

- Check all pivot connections, suspension and shock.

AIR RIDE SUSPENSION ASSEMBLY

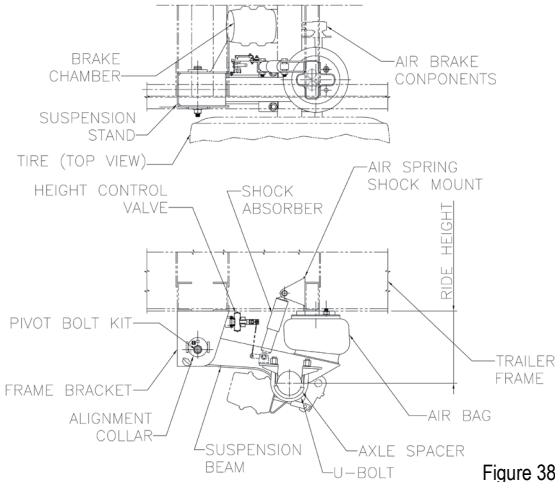

Figure 38



CAUTION

Do not raise chassis unless shock absorbers are in place. Without shocks, the air spring will be over-extended and damaged.

6.6.1 MAINTENANCE

1. AIR SPRING PROBLEMS

These seldom occur with the air springs unless they are rubbed, scuffed or punctured. If they fail, the chassis will settle down on the rubber bumper and you can drive to the next service depot for repairs. Identify and correct the cause of this problem before continuing.

2. AIR SPRING REPLACEMENT

- a. Exhaust air from system.
- b. Raise vehicle and support on safety stands.
- c. Remove air spring.
- d. Raise new air spring and tighten fasteners to their specified torque.

3. SHOCK ABSORBERS

Shock absorbers absorb vibration energy from the system and act as rebound stops for the suspension.

To replace shock absorber:

- Remove end fasteners.
- Install new shock absorbers using new mounting hardware.
- Tighten fasteners at their specified torque.

4. PIVOT BUSHING

The pivot bushing is a very durable, long lasting component. Failures are rare and replacement should be undertaken only when all other potential problem causes have been eliminated.

If replacement is required, obtain the removal/installation tool and replacement kit from your BWS dealer.

6.6.2 PIVOT CONNECTION

The eccentric bolt at the pivot connection should have the anti-turn washer installed. Proper welding can not occur without the washer in place. Check for proper welding as per manufacturer's specifications.

6.6.3 AIR CONTROL SYSTEM

Air is supplied to the air springs by the air supply system from the tractor. A single height control valve on one of the axles monitors the chassis height from the axle and adds or exhausts air from the system as required to maintain a constant distance. The dimension is variable for your trailer and can be controlled by the variable height control adjustment.

6.6.4 HEIGHT CONTROL VALVE

This valve controls the adding or exhausting of air from the air springs. Air is added when the distance between the axle and chassis is decreased. Air is exhausted when the distance increases. A 5 to 15 second time delay is built into the valve to minimize jerking. Replace the valve if it does not function properly (Figure 39)

6.6.5 HEIGHT CONTROL VALVE WITH DUAL RIDE HEIGHT

The use of a single solenoid valve, one or more Height Control Valves can be operated to adjust the air pressure in the spring bellows to a set second position. This valve can also be used to raise and lower crossing uneven surfaces, such as speed bumps in parking lots, or when loading and unloading the vehicle on ferry or transit units. This valve is used by BWS to raise the trailer when empty to get more ground clearance. (Figure 40):

HEIGHT CONTROL VALVE

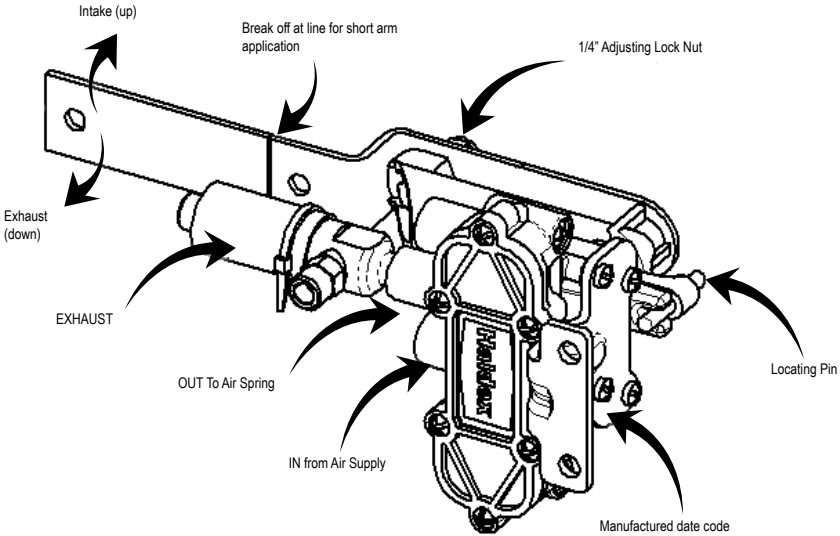

Figure 39

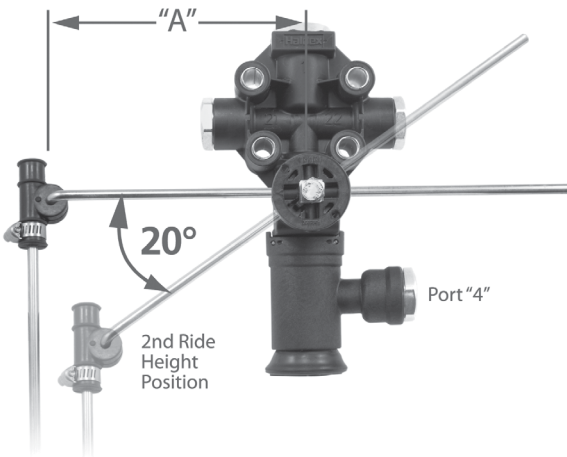

Figure 40

6.6.6 AIR DUMP VALVE

All air control systems are equipped with a dump valve that allows the operator to exhaust the air from the system in the following situations (Figure 41):

1. Parking trailer. (loaded or unloaded)
2. Loading or unloading trailers when supported by the deck supports.

AIR DUMP VALVE WITH GAUGE

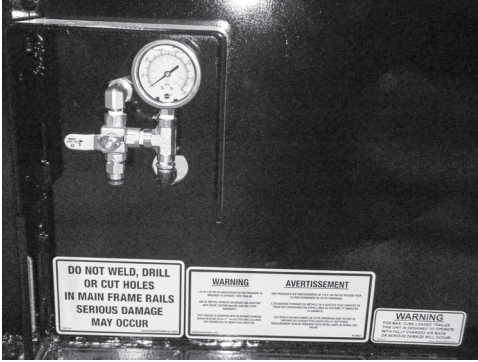

Figure 41

CAUTION

Always release brakes when exhausting the air from the air system to allow the axles to pivot to their new position; preventing deck support damage.

6.7 BRAKES

BRAKE CHAMBER

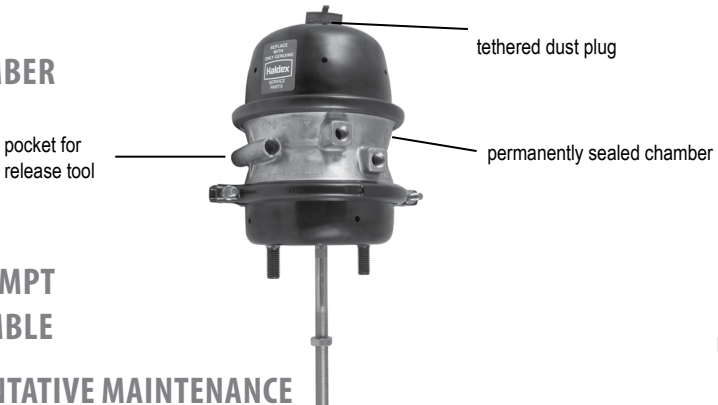

Figure 42

CAUTION:

DO NOT ATTEMPT TO DISASSEMBLE

6.7.1 PREVENTATIVE MAINTENANCE

The operator, on the basis of past experience and severity of operation, should establish a schedule for the periodic cleaning, adjustment and inspection of brake equipment. Drum and linings are particularly subject to wear.

The air brake system needs to be inspected, cleaned, lubricated and adjusted on a regular basis and each time the hubs are removed.

1. BRAKE DRUMS

Inspect brake drums. Any accumulation of mud, dirt or rust on the drums should be removed. Any broken or cracked drums should be removed from service. Brake drum manufacturers do not recommend re-boring of brake drums because of the reduced strength of refaced drums.

2. BRAKE LINING

Check and determine how much of the lining has been worn. Replace linings as required by current safety legislation.

ITEM	PART NAME
1	Retaining Ring
2	Camshaft Adjusting Washer
3	Steel Spacer
4	Grease Seal
5	Camshaft Bushing
6	Grease Fitting
7	Bracket Mounting Bolt
8	Lock Washer
9	Camshaft Bracket
10	Dust Shield Mounting Bolt
11	Lock Washer
12	Dust Shield (Half)
13	Spider Sub-Assembly
14	Anchor Pin Bushing
15	Anchor Pin

ITEM	PART NAME
16	Steel Spacer Plate
17	Camshaft
18	Cam Roller
19	Shoe and Lining Assembly
20	Return Spring Pin
21	Show Retainer Spring
22	Show Return Spring
23	Lining
24	Brake Lining Rivet
25	Snap Ring
26	Washer
27	Bronze Bushing
28	Brake Roller Spring
29	Matching Screw/Nut Combination

BRAKE COMPONENT IDENTIFICATION

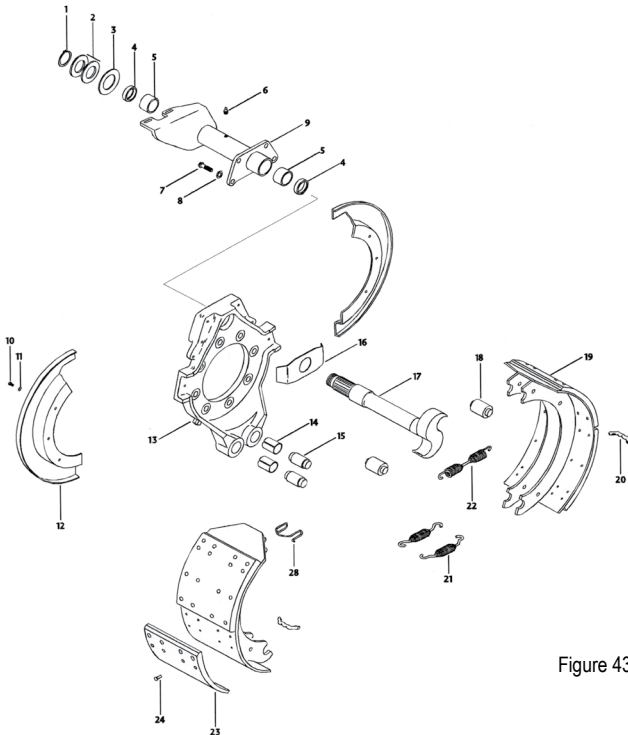

Figure 43

6.7.2 MAINTENANCE

1. BRAKES

Your BWS trailer is equipped with quick change brakes. These brakes require no maintenance unless they have had oil leaking on them and then they must be replaced. Adjustable brakes maintenance and practices can be obtained from your brake manufacture.

2. AUTOMATIC SLACK ADJUSTERS

Trailers are equipped with automatic (self-adjusting) slack adjusters. A self-adjusting slack adjuster should never have to be manually adjusted while in service. The only time it should be adjusted is during installation or at re-line. By constantly manually adjusting, the internal clutch life can be shortened. Consult individual manufacturer for proper adjustment procedure. (Figure 44A, & 44B)

SLACK ADJUSTER SCHEMATIC

! WARNING!

Do not attempt to repair or disassemble air brake chambers. A spring brake contains a very powerful compression spring. Incorrect handling may result in forceful release of the piggy back spring chamber and it's contents which could cause death, severe personal injury and/or property damage.

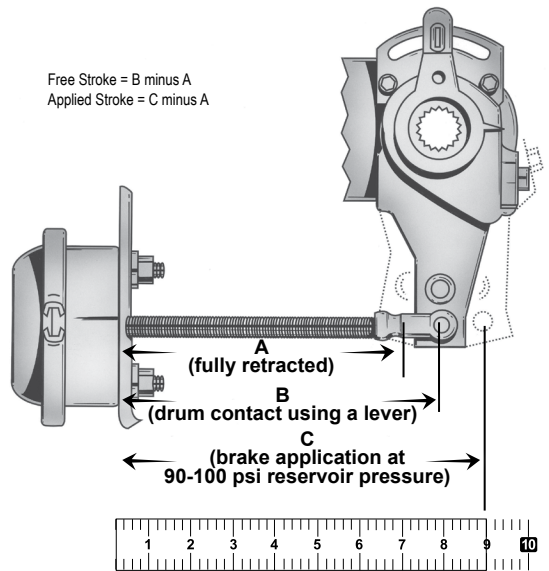

HALDEX AUTO SLACK ADJUSTER

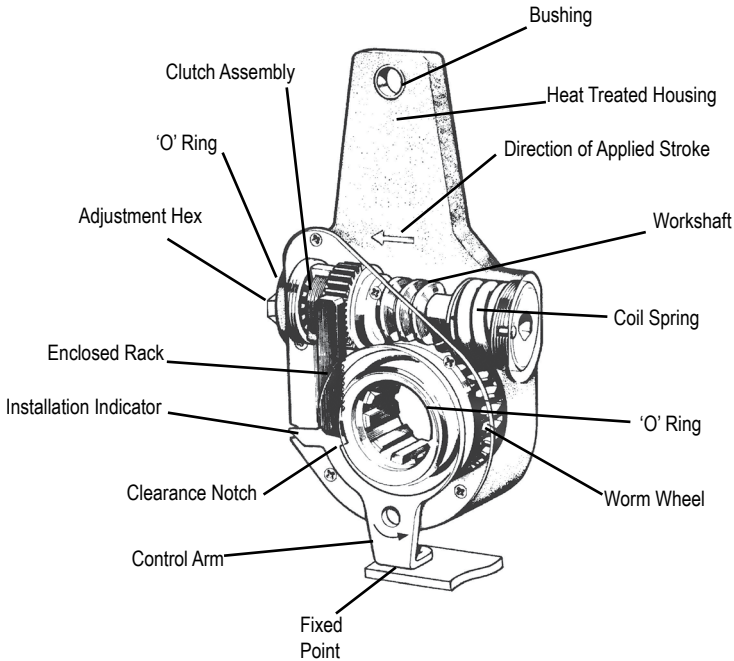

Figure 44B

6.8 TIRES

6.8.1 TIRE CARE AND MAINTENANCE

Although seemingly not requiring instruction, it has been established that through neglect, tires wear fast or fail early, even with the best of maintenance and service that tires deliver.

6.8.2 TIRE INSPECTION

A regular inspection of the tires is the first step in increasing tire mileage. These inspections will help to identify troubles, such as under-inflation, over-inflation and improper alignment. Minor damages, that may be repaired, can be detected during these inspections and save a tire that would otherwise fail.

Inflate tires to manufacturers recommended pressures. Proper inflation costs nothing, but will increase tire mileage. Under-inflation causes abnormal wear at the sides of the tread because the outer edges of the tire carry the load, while the center tends to flex up away from the road. This causes the tire to run hotter.

Tires found to be under-inflated before operation should be returned to the proper pressure. Over-inflation causes abnormal wear at the center of the tread, also shortening the life of the tire. This is caused because the center of the tire tread carries more than its share of the load.

Check for correct pressure when tires are cool. When a tire is in use and becomes heated, the air in the tire expands and the air pressure increases. Normal pressure build up is 20 pounds or less. Never "bleed" the tire to relieve build up pressure. If excessive build up of pressure occurs, load distribution, under-inflation, speed or any combination of these is responsible.

Over-inflation reduces the ability of the tire to absorb ordinary shock and causes fabric or tread separation, or both, resulting in tire failures. It will not compensate for overloading. An over-inflated tire is more vulnerable to snags, cuts and punctures.

6.8.3 MECHANICAL IRREGULARITIES

Mechanical irregularities that will cause excessive wear include a sprung or sagging axle, which will cause the inside dual tire to carry a greater load.

Brakes that are out of adjustment, or out-of-round brake drums will contribute to rapid and spotty tire wear. Improper brake adjustments will lead to spotty tire wear in several places, while out-of-round drums usually wear in a single spot. Improperly adjusted or worn wheel bearings can lead to uneven tire wear. Also improper axle alignment and worn torque rods bushings will cause excessive tire wear.

6.8.4 RADIAL TIRE APPLICATION

Radial and bias-ply tires should never be "mixed" either in dual combination or on the same axle except in an emergency situation. "Mixing" on the same dual combination will result in uneven wear because of different flexing characteristics.

6.8.5 MATCHING TIRES TO RIMS

When mounting tires on rims, be sure the right tires are used on the right rims. Many tire failures can be traced to not having matched the tires properly. In most cases there is a preferred and an alternate rim for the popular tire sizes. The preferred widths are recommended as they provide the optimum rim for the tire ratio. Refer to manufacturer's recommendations.

The tires of each wheel must be matched to within 1/8" of the same rolling radius (3/4" of the same rolling circumference) under normal loading conditions. The tires should have equal pressures.

6.8.6 TIRE WEAR PATTERNS

OVER-INFLATION:

Excessive wear at the center of the tire indicates the air pressure in the tire is consistently too high. The tire is riding on the center tread and wearing it prematurely. Occasionally, this wear pattern can result from extremely wide tires on narrow rims. To correct, replace either the tires or the wheels.

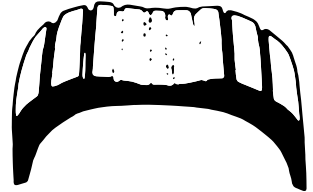

Figure 45

UNDER-INFLATION:

This type of wear usually results from consistent under-inflation. When a tire is under-inflated, there is too much contact with the road by the outer treads, which wear prematurely. When this type of wear occurs and the tire pressure is known to be consistently correct, the need for axle alignment could be indicated.

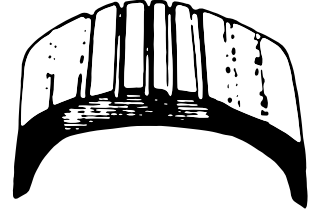

Figure 46

FEATHERING:

Feathering is a condition when the edge of each tread rib develops a slightly rounded edge on one side and a sharp edge on the other. By running your hand over the tire, you can usually feel the sharper edges before you will be able to see them. The most common causes of feathering are an incorrect toe-in setting, deteriorated bushing in the suspension or misalignment.

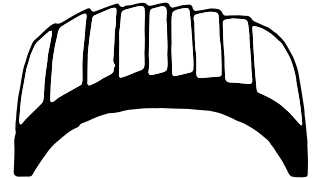

Figure 47

ONE SIDE WEAR:

When an inner or outer rib wears faster than the rest of the tire, the need for axle alignment is indicated. Misalignment could also be due to sagging springs or worn suspension system components.

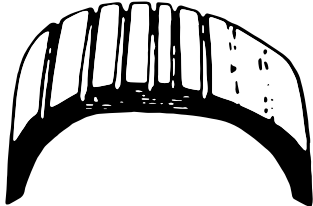

Figure 48

CUPPING:

Cups or scalloped dips appearing around the edge of the tread almost always indicate worn (sometimes bent) suspension parts. Adjustments of axle alignment alone will seldom cure the problem. Any worn component that connects the wheel to the suspension can cause this type of wear. Occasionally, wheels that are out of balance will wear like this, but wheel imbalance usually shows up as bald spots between the outside edges and centre of the tread.

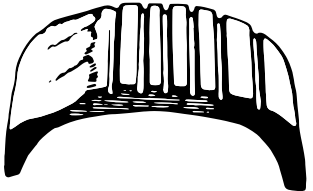

Figure 49

SECOND RIB WEAR:

Second rib wear is usually found only in radial tires, and appears where the steel belts end in relation to the tread. It can be kept to a minimum by careful attention to tire pressure and frequently rotating the tires. This is often considered normal wear but excessive amounts indicate that the tires are too wide for the wheels.



Figure 50

6.9 AIR SYSTEM COMPONENTS

Pressurized air is supplied to the system by the tractor and provides power to release and operate service and parking brakes. A variety of valves can be at various locations in the system and valves must be inspected and functionally checked on a regular basis to insure proper operation.

6.9.1 GLAD HANDS

During the pre-trip inspection, the driver should inspect the glad hands (Figure 51). Check for worn or damaged parts. Replace or repair as required.

6.9.2 ABS

BWS trailers incorporate a Haldex ABS systems. BWS reserves the right to change suppliers at any time. The following web sites contain valuable information including downloadable copies of ABS service and maintenance manuals.

HALDEX:

www.hbsna.com (ABS manual: L30030HBS)

GLAD HANDS - FRONT

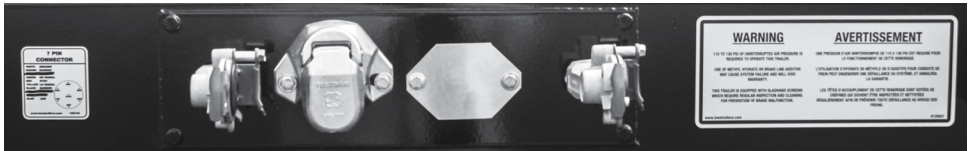

Figure 51

IMPORTANT!

The air system works best when clean, dry air is supplied from the tractor. Equipping the system with a dryer and a filter pays dividends by reducing maintenance requirements.

6.10 ELECTRICAL SYSTEM

The electrical system features modular, vapor proof GROTE Ultra Blue system that conforms with LED CMVSS 108/FMVSS 108. The lighting system incorporates LEDz sealed beam tail-lights and shock resistant clearance lights (Figure 52 through 55).

It is important that all systems are checked each day or before every trip, and that lenses and reflective identification devices are kept clean. The operator should periodically, during night operation, check for lights flickering or momentary outages. This often indicates loose connections, light bulb or lens problems.

TAIL LIGHTS

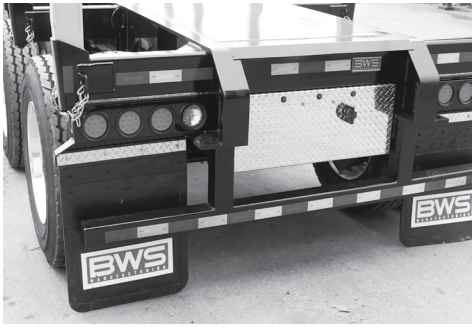

Figure 52

FRONT MARKER LIGHTS



Figure 53

ELECTRICAL DECAL

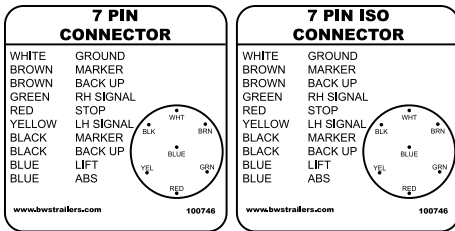

Figure 54

MIDWAY TURN SIGNALS

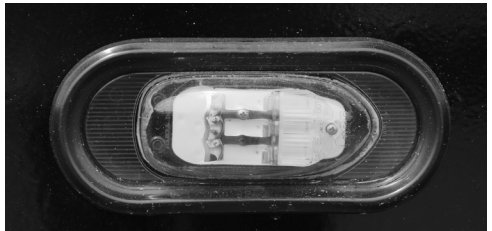
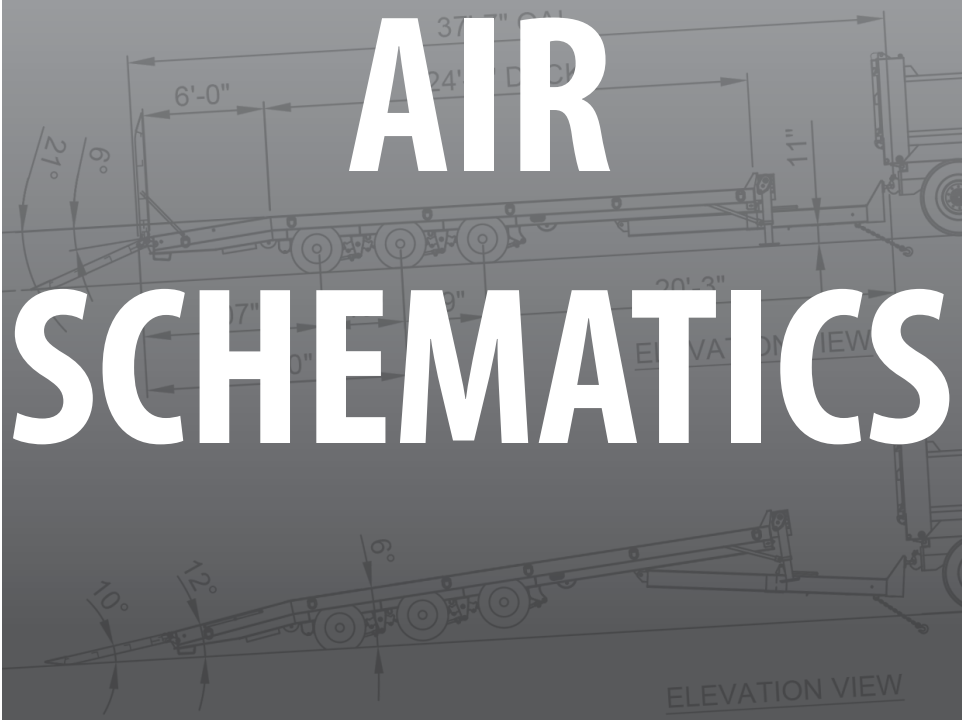
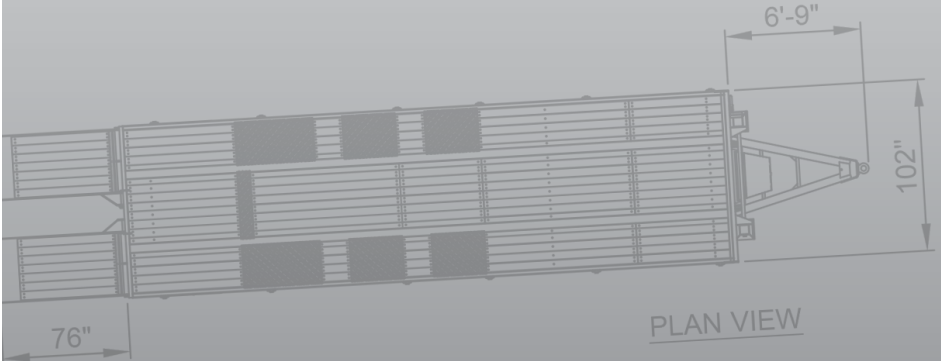

Figure 55

! MAINTENANCE SAFETY

- Always block vehicle wheels. Stop engine when working under a vehicle. Depleting vehicle air system pressure may cause a vehicle to roll. Keep hands away from chamber push rods and slack adjusters; they may automatically apply as system pressure drops.
- Never connect or disconnect a hose or line containing air pressure. It may whip as air escapes. Never remove a component or pipe plug unless you are certain all system pressure has been depleted.
- Never exceed recommended air pressure and always wear safety glasses when working with air pressure. Never look into air jets or direct them at anyone.
- Never attempt to disassemble a component until you have read and understood recommended procedures. Some components contain powerful springs and injury can result if not properly disassembled. Use only proper tools and observe all precautions pertaining to use of those tools.
- Use original manufacturer replacement parts and components.
 - Only components, devices, mounting and attaching hardware specifically designed should be used.
 - Replacement hardware, tubing, hose fittings, etc. should be the equivalent size, type, length and strength as the original equipment.
 - Make certain that when replacing tubing or hose, all supports, clamps or suspending devices that were originally installed by the vehicle manufacturer are reinstalled.
 - Devices with stripped threads or damaged parts should be replaced. Repairs requiring machining should not be attempted.

7.0 AIR SCHEMATICS



AIR SCHEMATICS

SUSPENSION HIGHWAY

HF2X, 48HD2X,
REV.1, PS2A211-HAL

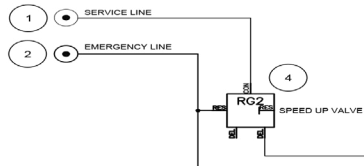

NOTES:

- 1) THIS IS A GENERAL LAYOUT WHICH SHOWS STANDARD AND COMMONLY OPTIONED COMPONENTS.
- 2) LOCATION OF CERTAIN COMPONENTS MAY VARY BY TRAILER. SOME OPTIONAL COMPONENTS MAY NOT BE SHOWN.
- 3) SOME PARTS SUCH AS VALVES VARY BY TRAILER. CHECK PART NUMBER WITH BWS PARTS DEPARTMENT BEFORE ORDERING REPLACEMENTS.
- 4) SPEED UP VALVE GENERALLY ONLY INSTALLED ON LONG TRAILERS OR TRAILERS WITH LIFT AXLE.
- 5) SUSPENSION AIR BAGS VARY BY TRAILER MODEL BASED ON LOAD CAPACITY AND RIDE HEIGHT.

#	DESCRIPTION	P/N	QTY
1	SERVICE GLAD HAND	40192	1
2	EMERGENCY GLAD HAND	40193	1
3	2S/1M ABS VALVE	401824	1
4	RG2 VALVE	40853	1
5	AIR GAUGE BWS	08290	1
6	HEIGHT CONTROL VALVE	40572	1
7	BRAKE POT	402051	4
8	MANUAL DUMP VALVE	63133	1
9	LARGE AIR TANK	401052	1
10	AIR HOSE BLACK 3/8" X 24"	40511	8
11	PRESSURE PROTECTION VALVE	40839	1
12	SUSPENSION AIR BAG	(NOTE 5)	4

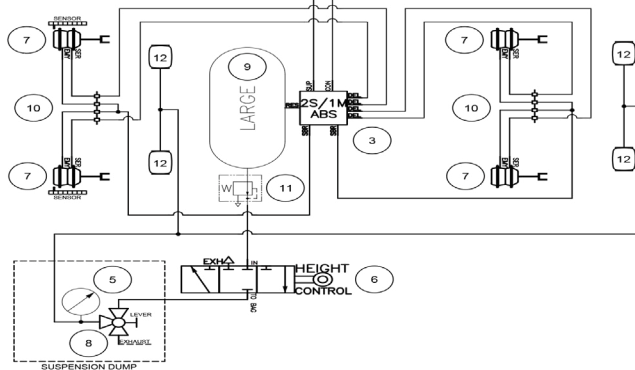

1	LCH	2014/07/24	REVIEW, LAYOUT UPDATES, CHANGED DUMP VALVE.	
0	AMF	2005/05/24	INITIAL ISSUE.	LCH
REV.	BY	DATE	DESCRIPTION	CHK'D
			BWS Manufacturing Ltd. 10 MONTANA ST. CENTREVILLE, N.B. CANADA E7K 3E9 PH: (506) 276-4567 FAX: (506) 276-4380	
DRAWN BY A FAULKNER			DATE 2005/05/24	SCALE 1/2"=1'-0"
UNIT 2 AXLE AIR RIDE TRAILER W/ HALDEX 2S/1M, 1 AIR TANK		TITLE AIR SCHEMATIC		
SHT	1 OF 1	MODEL	HF,HD	DWG. No. PS2A211-HAL
				REV 1

← FRONT OF TRAILER

HIGHWAY

HF3X, 51LF3X3T SK, 53LD3X3T BC

REV.3, PS3A212-HAL

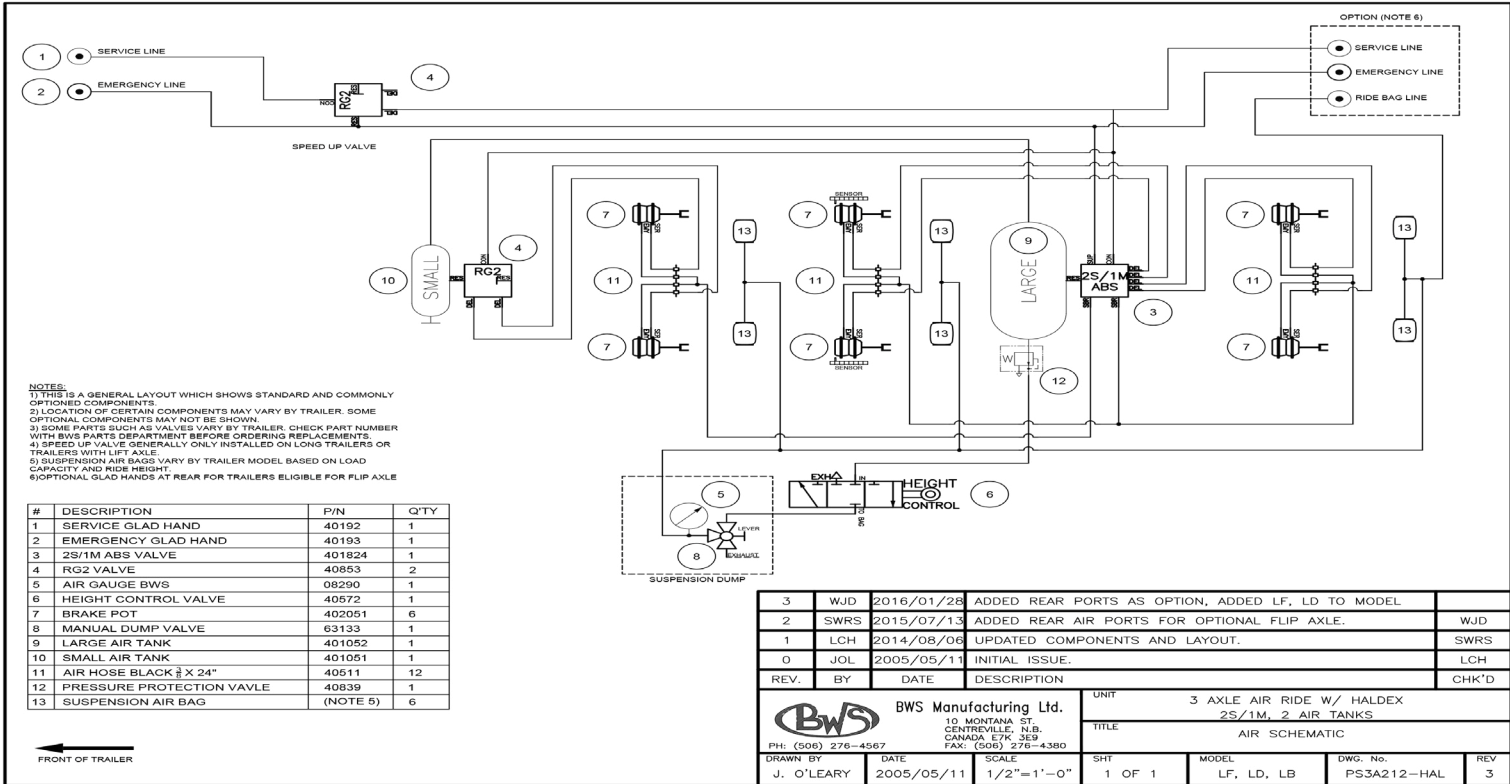

JEEP

20JD1X

REV.0, PS1A1JX

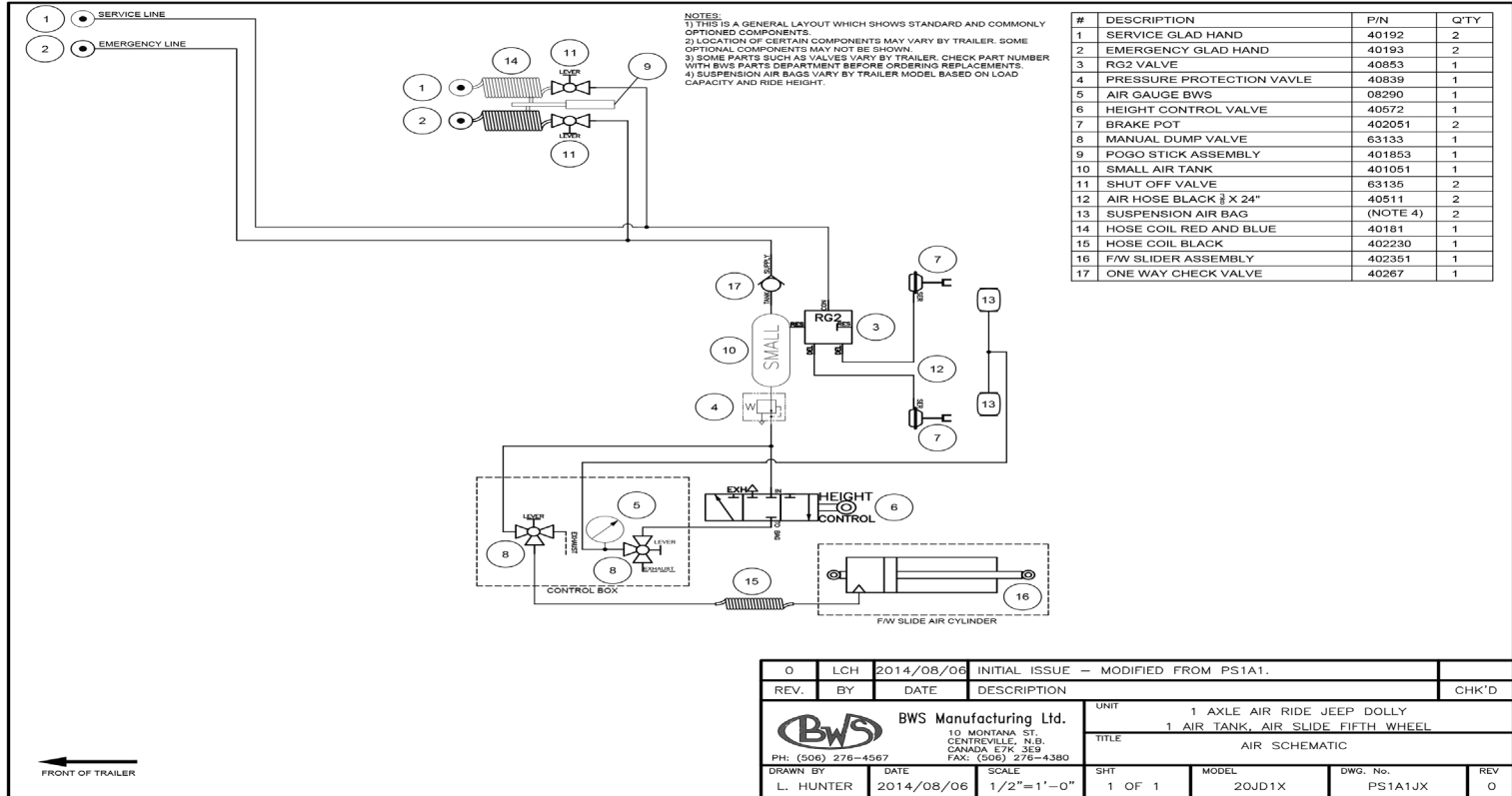

0	LCH	2014/08/06	INITIAL ISSUE - MODIFIED FROM PS1A1.			
REV.	BY	DATE	DESCRIPTION	CHK'D		
 BWS Manufacturing Ltd. 10 MONTANA ST. CENTREVILLE, N.B. CANADA E7K 3E9 PH: (506) 276-4567 FAX: (506) 276-4380			UNIT	1 AXLE AIR RIDE JEEP DOLLY		
			TITLE	1 AIR TANK, AIR SLIDE FIFTH WHEEL AIR SCHEMATIC		
DRAWN BY	DATE	SCALE	SHT	MODEL	DWG. No.	REV
L. HUNTER	2014/08/06	1/2"=1'-0"	1 OF 1	20JD1X	PS1A1JX	0

← FRONT OF TRAILER



JEEP

40JD2X WL

REV.0, PS2A2115JNX

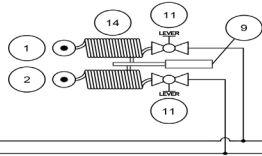

NOTES:
1) THIS IS A GENERAL LAYOUT WHICH SHOWS STANDARD AND COMMONLY OPTIONED COMPONENTS
2) LOCATION OF CERTAIN COMPONENTS MAY VARY BY TRAILER. SOME OPTIONAL COMPONENTS MAY NOT BE SHOWN.
3) SOME PARTS SUCH AS VALVES VARY BY TRAILER. CHECK PART NUMBER WITH BWS PARTS DEPARTMENT BEFORE ORDERING REPLACEMENTS.
4) SUSPENSION AIR BAGS VARY BY TRAILER MODEL BASED ON LOAD CAPACITY AND RIDE HEIGHT.

#	DESCRIPTION	P/N	Q'TY
1	SERVICE GLAD HAND	40192	2
2	EMERGENCY GLAD HAND	40193	2
3	FF2 VALVE	40808	1
4	PRESSURE PROTECTION VALVE	40839	1
5	AIR GAUGE BWS	08290	1
6	HEIGHT CONTROL VALVE	40572	1
7	BRAKE POT	402051	4
8	MANUAL DUMP VALVE	63133	1
9	POGO STICK ASSEMBLY	401853	1
10	LARGE AIR TANK	401052	1
11	SHUT OFF VALVE	63135	2
12	AIR HOSE BLACK 3/4 X 24"	40511	8
13	SUSPENSION AIR BAG (NOTE 4)	1	1
14	HOSE COIL RED AND BLUE	40181	1
15	HOSE COIL BLACK	402230	1

AIR SCHEMATIC FOR 40JD2X NUCLEAR AND 40JD2X MANUAL SLIDE FIFTH WHEEL

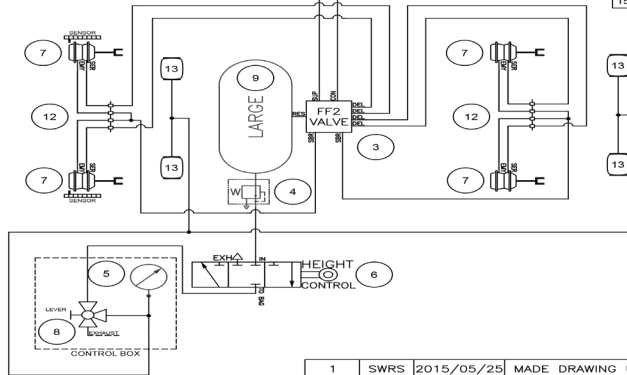

1	SWRS	2015/05/25	MADE DRAWING USABLE FOR MANUAL SLIDE FIFTH WHEEL JEEP AND UPDATED CONTROL BOX LAYOUT			
0	LCH	2014/08/19	INITIAL ISSUE - MODIFIED FROM PS2A211JX-HAL.		SWRS	
REV.	BY	DATE	DESCRIPTION		CHK'D	
			BWS Manufacturing Ltd.	UNIT	2 AXLE AIR RIDE JEEP DOLLY	
			10 MONTANA ST. CENTREVILLE, N.B. CANADA E7K 3E9 FAX: (506) 276-4380	TITLE	1 AIR TANK, NO ABS	
			PH: (506) 276-4567	AIR SCHEMATIC		
DRAWN BY	DATE	SCALE	SHT	MODEL	DWG. No.	REV
L. HUNTER	2014/08/18	1/2"=1'-0"	1 OF 1	40JD2X NUCLEAR	PS2A211JN	0

← FRONT OF TRAILER

BWS

JEEP

60JD3X

REV.0, PS3A212JX-HAL

NOTES:
 1) THIS IS A GENERAL LAYOUT WHICH SHOWS STANDARD AND COMMONLY OPTIONED COMPONENTS.
 2) LOCATION OF CERTAIN COMPONENTS MAY VARY BY TRAILER. SOME OPTIONAL COMPONENTS MAY NOT BE SHOWN.
 3) SOME PARTS SUCH AS VALVES VARY BY TRAILER. CHECK PART NUMBER WITH BWS PARTS DEPARTMENT BEFORE ORDERING REPLACEMENTS.

#	DESCRIPTION	P/N	Q'TY
1	SERVICE GLAD HAND	40192	2
2	EMERGENCY GLAD HAND	40193	2
3	2S/1M ABS VALVE	401824	1
4	RG2 VALVE	40853	1
5	AIR GAUGE BWS	08290	1
6	HEIGHT CONTROL VALVE	40572	1
7	BRAKE POT	402051	6
8	MANUAL DUMP VALVE	63133	2
9	LARGE AIR TANK	401052	1
10	SMALL AIR TANK	401051	1
11	AIR HOSE BLACK 1/2" X 24"	40511	12
12	PRESSURE PROTECTION VALVE	40839	1
13	BALL VALVE 1/2"	63127	2
14	POGO STICK ASSEMBLY	401853	1
15	F/W SLIDER ASSEMBLY	402189	1
16	HOSE COIL RED AND BLUE	40181	1
17	HOSE COIL BLACK	402230	1
18	SUSPENSION AIR BAG (NOTE 4)	63127	6
19	BALL VALVE 3/8"	63127	4

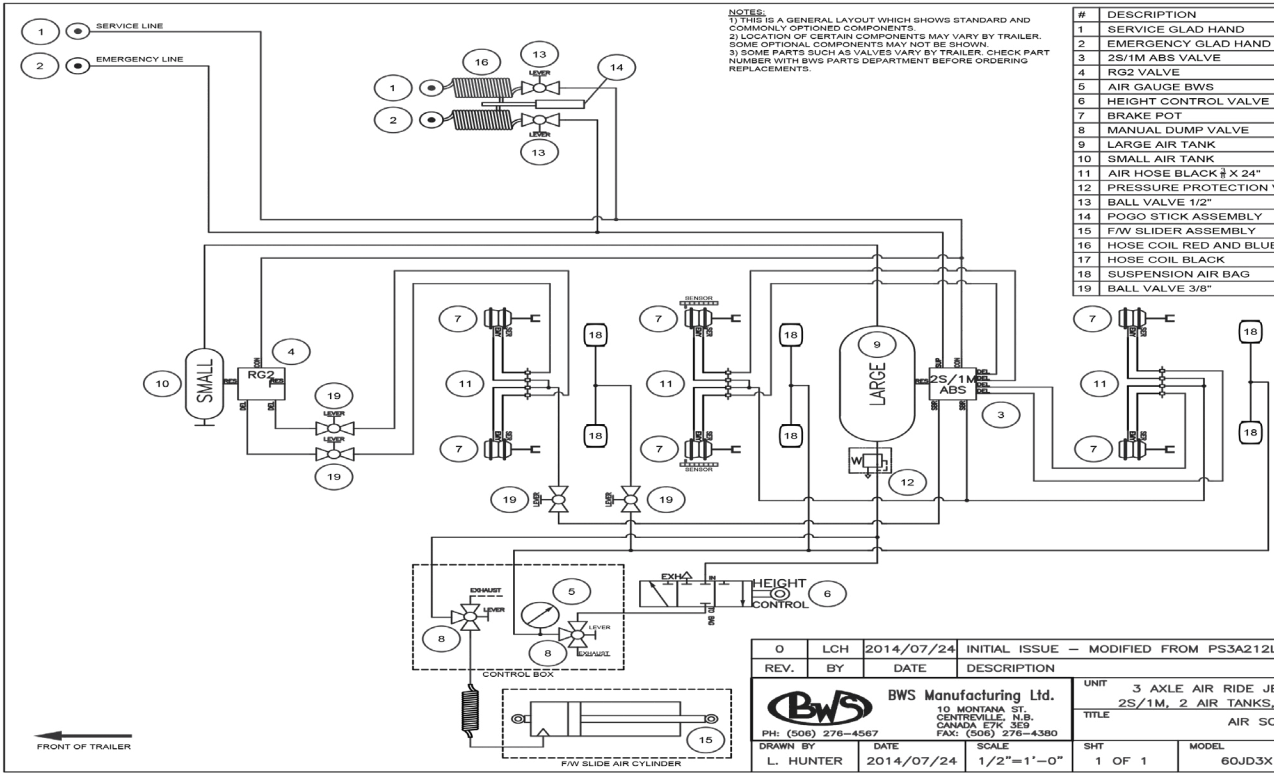

0	LCH	2014/07/24	INITIAL ISSUE - MODIFIED FROM PS3A212L-HAL	
REV.	BY	DATE	DESCRIPTION	CHK'D
			BWS Manufacturing Ltd. 10 MONTANA ST. CENTREVILLE, N.B. CANADA E7K 3E9 FAX: (506) 276-4360	
PH: (506) 276-4367 DRAWN BY L. HUNTER		DATE 2014/07/24	SCALE 1/2"=1'-0"	UNIT 3 AXLE AIR RIDE JEEP DOLLY W/ HALDEX 2S/1M, 2 AIR TANKS, AIR SLIDE FIFTH WHEEL TITLE AIR SCHEMATIC
SHT	1	OF	1	
MODEL	60JD3X		DWG. No.	PS3A212JX-HAL
REV	0			



LOGGING B-TRAIN

37LBT3XNL (Lead)

REV.1, PS3A212-NL-BTL

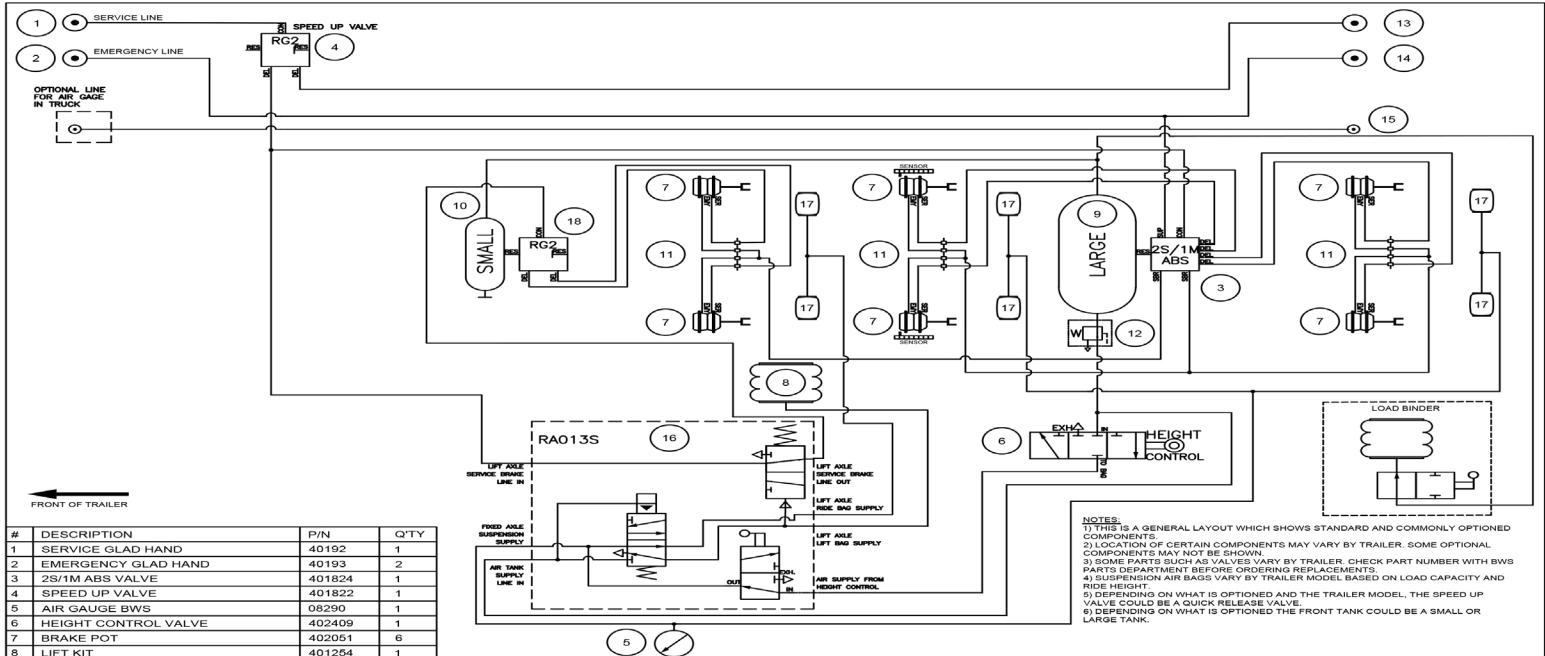

#	DESCRIPTION	P/N	QTY
1	SERVICE GLAD HAND	40192	1
2	EMERGENCY GLAD HAND	40193	2
3	2S/1M ABS VALVE	401824	1
4	SPEED UP VALVE	401822	1
5	AIR GAUGE BWS	08290	1
6	HEIGHT CONTROL VALVE	402409	1
7	BRAKE POT	402051	6
8	LIFT KIT	401254	1
9	LARGE AIR TANK	401052	1
10	SMALL AIR TANK	401051	1
11	AIR HOSE BLACK # X 24"	40511	4
12	PRESSURE PROTECTION VALVE	40839	1
13	SERVICE GLAD HAND W/ SHUTOFF	402129	1
14	EMERGENCY GLAD HAND W/ SHUTOFF	402133	1
15	QUICK CONNECT COUPLER MALE	04112	1
16	CONTROL BOX	40608	1
17	SUSPENSION AIR BAG	(NOTE 4)	8

NOTES:
 1) THIS IS A GENERAL LAYOUT WHICH SHOWS STANDARD AND COMMONLY OPTIONED COMPONENTS.
 2) LOCATION OF CERTAIN COMPONENTS MAY VARY BY TRAILER. SOME OPTIONAL COMPONENTS MAY NOT BE SHOWN.
 3) SOME PARTS SUCH AS VALVES VARY BY TRAILER. CHECK PART NUMBER WITH BWS PARTS DEPARTMENT BEFORE ORDERING REPLACEMENTS.
 4) SUSPENSION AIR BAGS VARY BY TRAILER MODEL BASED ON LOAD CAPACITY AND RIDE HEIGHT.
 5) DEPENDING ON WHAT IS OPTIONED AND THE TRAILER MODEL, THE SPEED UP VALVE COULD BE A QUICK RELEASE VALVE.
 6) DEPENDING ON WHAT IS OPTIONED THE FRONT TANK COULD BE A SMALL OR LARGE TANK.

REV.	BY	DATE	DESCRIPTION	CHK'D
0	WD	2016/02/02	INITIAL ISSUE—MOD FROM PS3A212—HAL—BTL	
BWS Manufacturing Ltd. 10 MONTANA ST. CENTREVILLE, N.B. CANADA E7K 3E9 PH: (506) 276-4367 FAX: (506) 276-4360			UNIT 3 AXLE AIR RIDE B-TRAIN LEAD W/ HALDEX 2S/1M, LIFT AXLE, LOAD BINDER TITLE AIR SCHEMATIC	
DRAWN BY	DATE	SCALE	SHT	MODEL
WD	2016/02/02	1/2"=1'-0"	1 OF 1	LBT-LEAD
			DWG. No.	REV
			PS3A212-NL-BTL	1



HIGHWAY / LOGGING B-TRAIN

28HBT2XHD, 27LBT2X (Pull)

REV.2, PS2A211-HAL-BTP

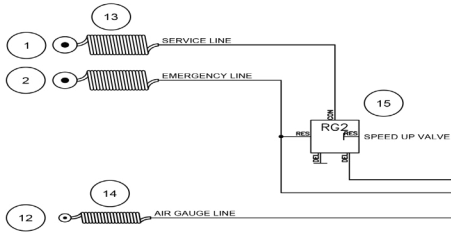

#	DESCRIPTION	P/N	Q'TY
1	SERVICE GLAD HAND	40192	1
2	EMERGENCY GLAD HAND	40193	1
3	2S/1M ABS VALVE	401824	1
4	SUSPENSION AIR BAG	(NOTE 4)	4
5	AIR GAUGE BWS	08290	1
6	HEIGHT CONTROL VALVE	40572	1
7	BRAKE POT	402051	4
8	MANUAL DUMP VALVE	63133	1
9	LARGE AIR TANK	401052	1
10	AIR HOSE BLACK 3/4 X 32"	401230	8
11	PRESSURE PROTECTION VALVE	40839	1
12	QUICK CONNECT COUPLER FEMALE	04111	1
13	HOSE COIL RED AND BLUE	40181	1
14	HOSE COIL BLACK	402230	1
15	RG2 SPEED UP VALVE	40853	1

NOTES:

- 1) THIS IS A GENERAL LAYOUT WHICH SHOWS STANDARD AND COMMONLY OPTIONED COMPONENTS.
- 2) LOCATION OF CERTAIN COMPONENTS MAY VARY BY TRAILER. SOME OPTIONAL COMPONENTS MAY NOT BE SHOWN.
- 3) SOME PARTS SUCH AS VALVES VARY BY TRAILER. CHECK PART NUMBER WITH BWS PARTS DEPARTMENT BEFORE ORDERING REPLACEMENTS.
- 4) SUSPENSION AIR BAGS VARY BY TRAILER MODEL BASED ON LOAD CAPACITY AND RIDE HEIGHT.

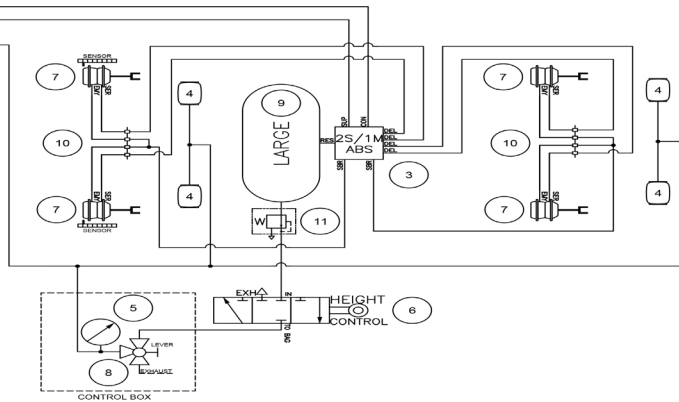

← FRONT OF TRAILER

2	SWRS	2015/05/20	FIXED LABELLING ERROR	
1	LCH	2014/08/26	ADDED SPEED UP VALVE.	SWRS
0	LCH	2014/08/07	INITIAL ISSUE - MODIFIED FROM PS2A211-HAL.	LCH
REV.	BY	DATE	DESCRIPTION	CHK'D

 BWS Manufacturing Ltd. 10 MONTANA ST. CENTREVILLE, N.B. CANADA E7K 3E9 PH: (506) 276-4567 FAX: (506) 276-4380		UNIT	2 AXLE B-TRAIN PULL W/ HALDEX			
		TITLE	2S/1M, AIR RIDE, 1 AIR TANK, AIR GAUGE LINE AIR SCHEMATIC			
DRAWN BY	DATE	SCALE	SHT	MODEL	DWG. No.	REV
L. HUNTER	2014/08/07	1/2"=1'-0"	1 OF 1	LBT-PULL	PS2A211-HAL-BTP	2

LOGGING

3 Axle with front lift axle (46LD3X4T, 48LF3X5TNB)

REV.4, PS3A212A-HAL

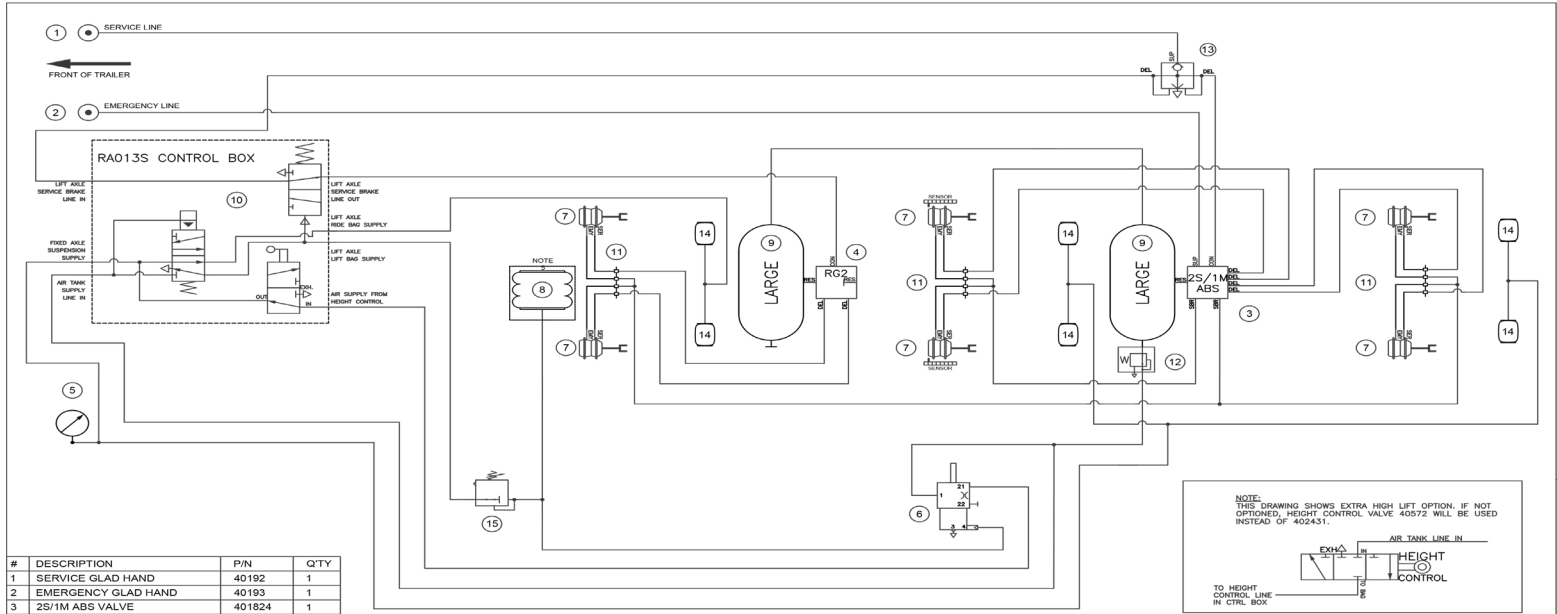

#	DESCRIPTION	P/N	QTY
1	SERVICE GLAD HAND	40192	1
2	EMERGENCY GLAD HAND	40193	1
3	2S/1M ABS VALVE	401824	1
4	RG2 VALVE	40853	1
5	AIR GAUGE BWS	08290	1
6	HEIGHT CONTROL VALVE	402431	1
7	BRAKE POT	402051	6
8	LIFT KIT	401254	1
9	LARGE AIR TANK	401052	2
10	CONTROL BOX	40669	1
11	AIR HOSE BLACK 3/4" X 24"	40511	12
12	PRESSURE PROTECTION VALVE	40839	1
13	QUICK RELEASE	40203	1
14	SUSPENSION AIR BAG (NOTE 4)	401457	1
15	NORGREN VALVE	401457	1

NOTES:
 1) THIS IS A GENERAL LAYOUT WHICH SHOWS STANDARD AND COMMONLY OPTIONED COMPONENTS.
 2) LOCATION OF CERTAIN COMPONENTS MAY VARY BY TRAILER. SOME OPTIONAL COMPONENTS MAY NOT BE SHOWN.
 3) SOME PARTS SUCH AS VALVES VARY BY TRAILER. CHECK PART NUMBER WITH BWS PARTS DEPARTMENT BEFORE ORDERING REPLACEMENTS.
 4) SUSPENSION AIR BAGS VARY BY TRAILER MODEL BASED ON LOAD CAPACITY AND RIDE HEIGHT.
 5) LIFT KIT OPTION IS APPLICABLE ON ANY AXLE.

MODELS APPLICABLE TO SCHEMATIC

- 46LD3X4T NS
- 48LD3X 5T NB
- 51LF3X3T SK
- 53LD3X 3T BC
- 55LB3X SND

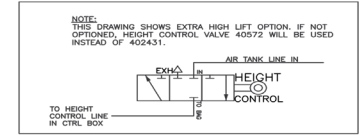

4	JTU	2016/10/20	REVISED SCHEMATIC, LARGER BORDER, REDUCED CLUTTER + CR INFO.	
3	WJD	2016/10/05	UPDATED LAYOUT, ADDED NOTE 5.	
2	BWRS	2015/05/20	UPDATE HEIGHT CONTROL, AND ADDED NORGREN VALVE.	WJD
1	LCH	2014/09/23	UPDATED COMPONENTS AND LAYOUT.	BWRS
0	AMF	2016/10/20	INITIAL ISSUE, MODIFIED FROM PS3A212AB-HAL-DWG	LCHT
REV. I	BY	DATE	DESCRIPTION	CHK'D
WELDING:	PROCEDURES AS PER APPROVED CWB PROCEDURES ONLY			
SIZES:	UNLESS SPECIFIED OTHERWISE			
TOLERANCES:	SAW ± 1/16" BORE ± 1/16" BROWNSON ± 1/16" BRASS ± 1"			
	LATHES ± .005" MILLING ± .005" DRILL ± .005" TURN ± .005"			
			UNIT: AXLE AIR RIDE TRAILER W/ HALDEX FRONT AXLE AIR LIFT & 2S/1M ABS AIR SCHEMATIC	
PH: (609) 378-6887	FAX: (609) 378-4300			
DESIGNED BY: J. UNDERHILL	DATE: 2016/10/05	SCALE: 1/2"=1'-0"	SHEET: 1 OF 1	MODEL: LD, LF
			DWG. NO.: PS3A212A-HAL	REV: 4



LOGGING

46LF4X-NL (lift axle, steer lock and load binders)

REV.0, PS4A213ASSA-NL

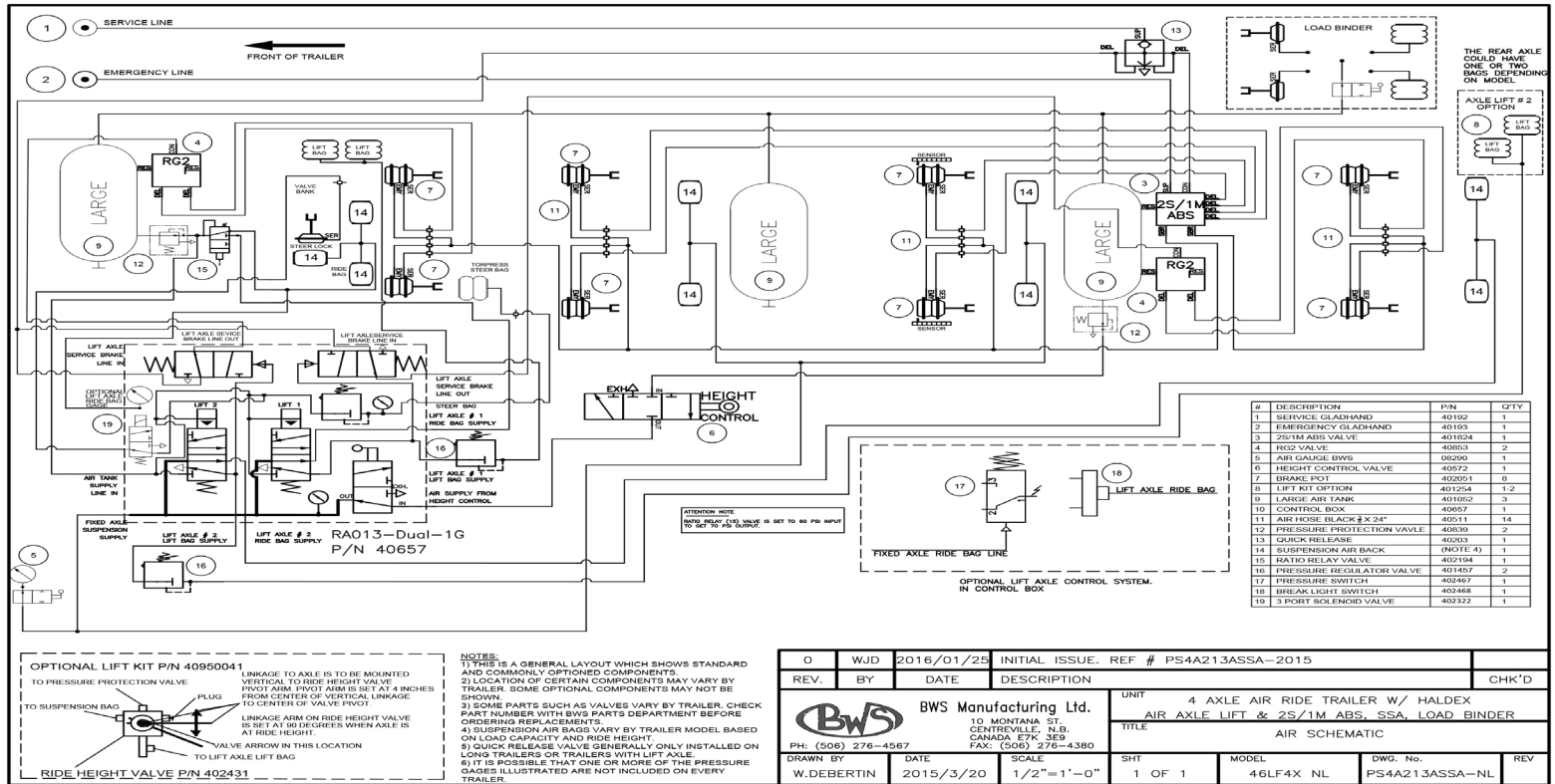

LOGGING

51LF4X5TNB, 51LD4X5T NS/NB (lift axle, steer lock)

REV.0, PSA4213ASSA-2016

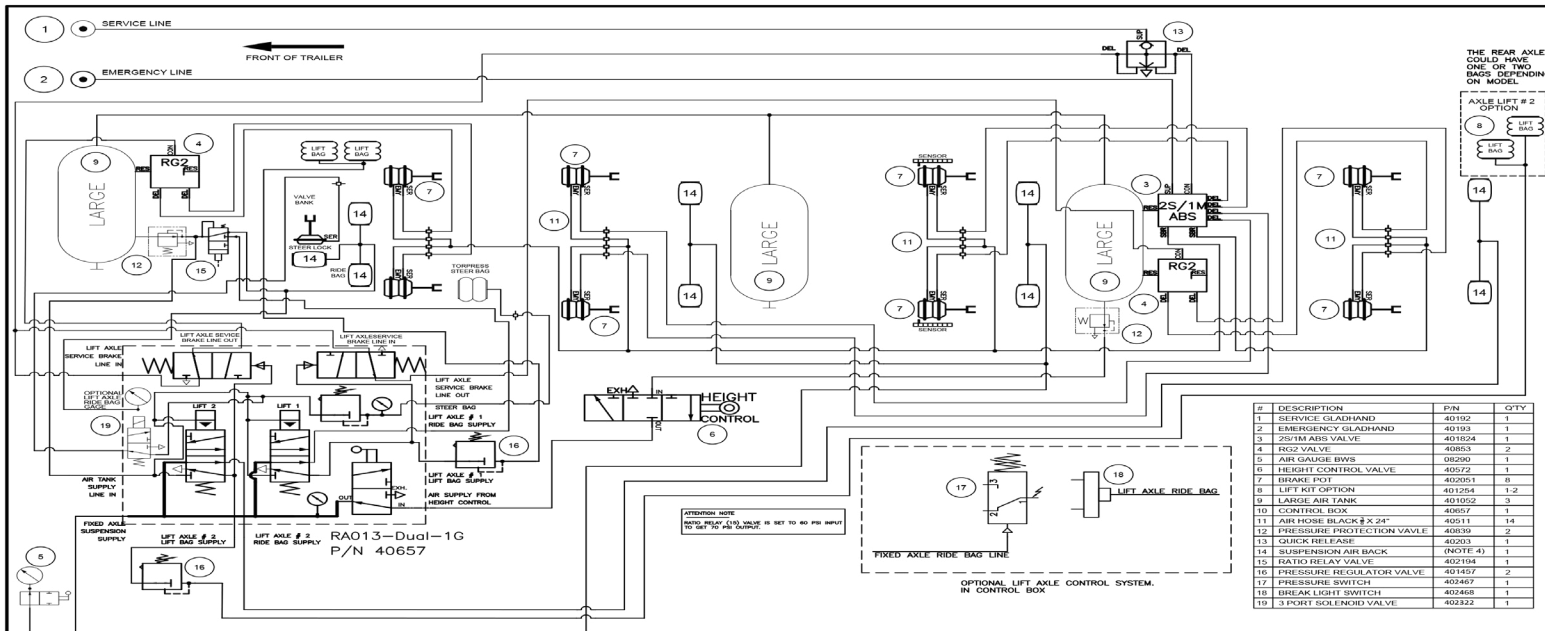

#	DESCRIPTION	P/N	QTY
1	SERVICE GLADHAND	40192	1
2	EMERGENCY GLADHAND	40193	1
3	2S/1M ABS VALVE	401924	1
4	RG2 VALVE	40603	2
5	AIR GAUGE BWS	06200	1
6	HEIGHT CONTROL VALVE	40572	1
7	BI-RAMP KIT	40201	8
8	LIFT KIT OPTION	401254	1-2
9	LARGE AIR TANK	401052	3
10	CONTROL BOX	40657	1
11	AIR HOSE BLACK 3/4 X 24'	40511	14
12	PRESSURE PROTECTION VALVE	40039	2
13	QUICK RELEASE	40203	1
14	SUSPENSION AIR BAG	(NOTE 4)	1
15	RATCH RELAY VALVE	402104	1
16	PRESSURE REGULATOR VALVE	401427	2
17	PRESSURE SWITCH	402467	1
18	BREAK LIGHT SWITCH	402468	1
19	3 PORT SOLENOID VALVE	402322	1

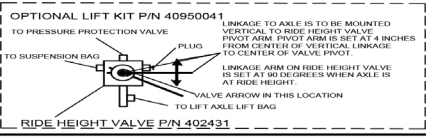

NOTES:
 1) THIS IS A GENERAL LAYOUT WHICH SHOWS STANDARD AND COMMONLY OPTIONED COMPONENTS.
 2) LOCATION OF CERTAIN COMPONENTS MAY VARY BY TRAILER. SOME OPTIONAL COMPONENTS MAY NOT BE SHOWN.
 3) SOME PARTS SUCH AS VALVES VARY BY TRAILER. CHECK PART NUMBER WITH BWS PARTS DEPARTMENT BEFORE ORDERING REPLACEMENTS.
 4) SUSPENSION AIR BAGS VARY BY TRAILER MODEL BASED ON LOAD CAPACITY AND RIDE HEIGHT.
 5) QUICK RELEASE VALVE GENERALLY ONLY INSTALLED ON LONG TRAILERS OR TRAILERS WITH LIFT AXLE.
 6) IT IS POSSIBLE THAT ONE OR MORE OF THE PRESSURE GAUGES ILLUSTRATED ARE NOT INCLUDED ON EVERY TRAILER.

0	WJD	2016/01/25	INITIAL ISSUE. REF # PSA4213ASSA-2015		
REV.	BY	DATE	DESCRIPTION		CHK'D
			BWS Manufacturing Ltd. 10 MONTANA ST. CENTREVILLE, N.B. CANADA E7K 3E9 FAX: (506) 276-4380	UNIT	4 AXLE AIR RIDE TRAILER W/ HALDEX
				TITLE	AIR AXLE LIFT & 2S/1M ABS, RIDE WELL SHL/SSA.
				AIR SCHEMATIC	
DRAWN BY	DATE	SCALE	SHT	MODEL	DWG. No.
W. DEBERTIN	2016/01/25	1/2"=1'-0"	1 OF 1	LD, LF	PS4A213ASSA-2016



LOGGING

50LF3X3T AB (4th Axle ready)

REV.0, PS3A212-WL

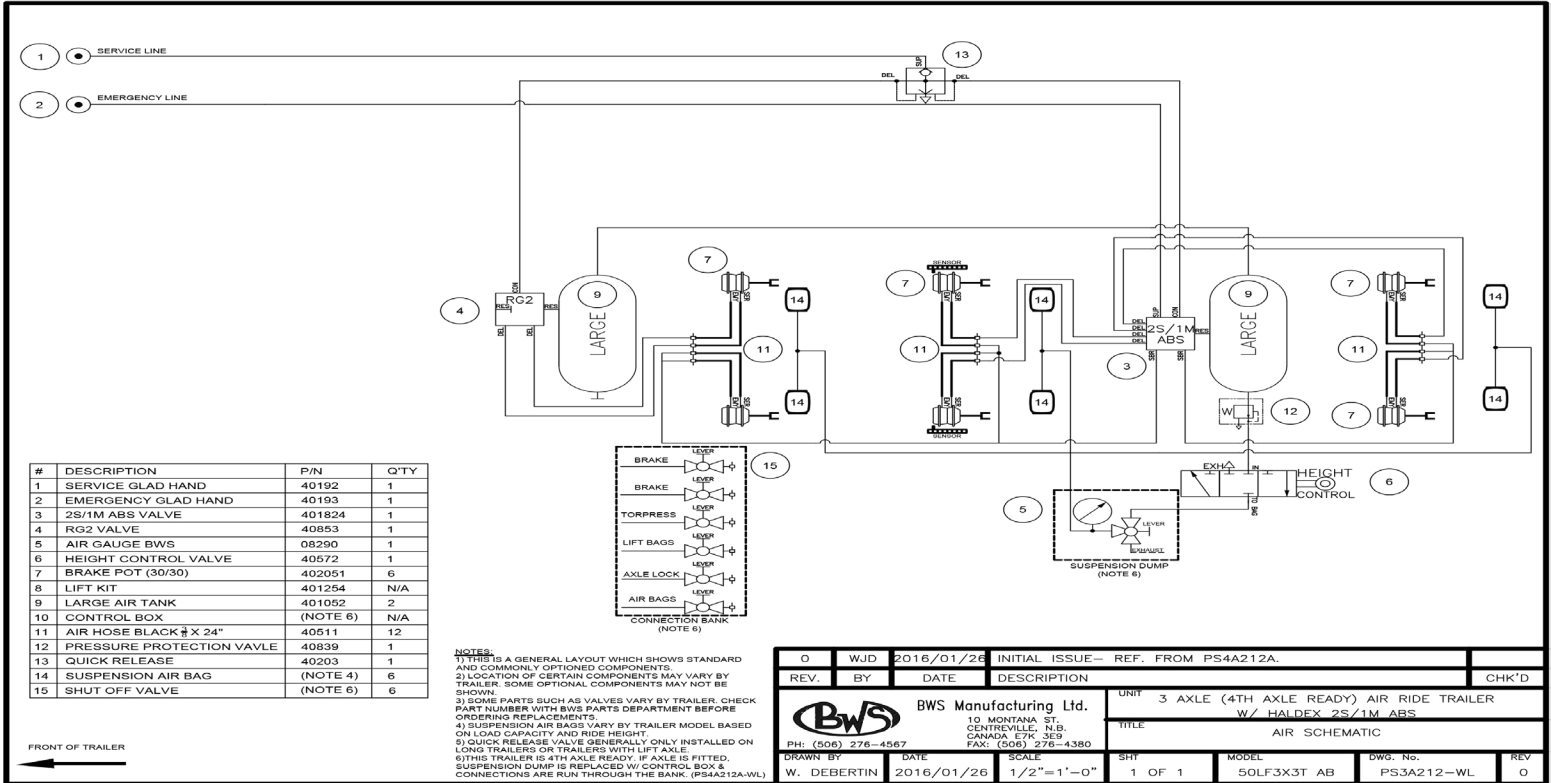

0	WJD	2016/01/26	INITIAL ISSUE-- REF. FROM PS4A212A.	UNIT	3 AXLE (4TH AXLE READY) AIR RIDE TRAILER
REV.	BY	DATE	DESCRIPTION	TITLE	W/ HALDEX 2S/1M ABS
			BWS Manufacturing Ltd. 10 MONTANA ST. CENTREVILLE, N.B. CANADA E7K 3E9 FAX: (506) 276-4380		
DRAWN BY	DATE	SCALE	SHT	MODEL	BWG. No.
W. DEBERTIN	2016/01/26	1/2"=1'-0"	1 OF 1	50LF3X3T AB	PS3A212-WL
					REV 0



DUMP TRAILER

27DT2X

REV.2, PS2A211CX-HAL

DRAWING SHOWS HIGHLIFT OPTION

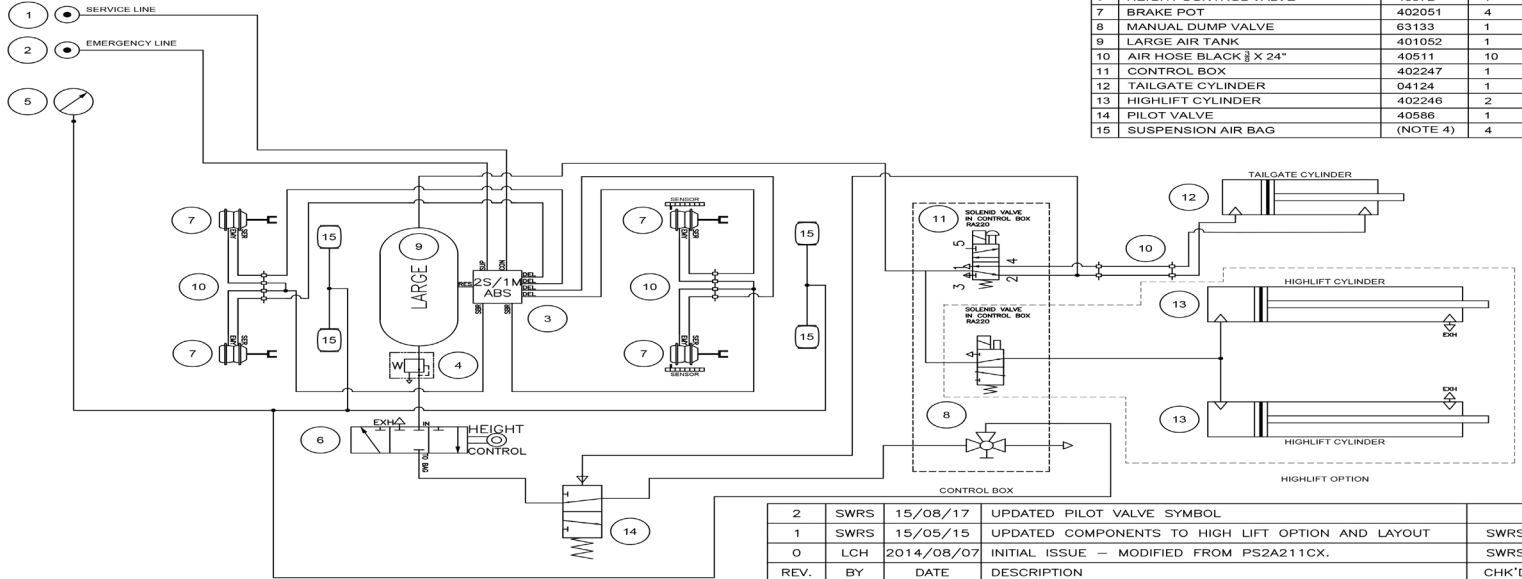

NOTES:

- 1) THIS IS A GENERAL LAYOUT WHICH SHOWS STANDARD AND COMMONLY OPTIONED COMPONENTS
- 2) LOCATION OF CERTAIN COMPONENTS MAY VARY BY TRAILER. SOME OPTIONAL COMPONENTS MAY NOT BE SHOWN
- 3) SOME PARTS SUCH AS VALVES VARY BY TRAILER. CHECK PART NUMBER WITH BWS PARTS DEPARTMENT BEFORE ORDERING REPLACEMENTS
- 4) SUSPENSION AIR BAGS ARE PART OF THE SUSPENSION ASSEMBLY FOR EACH AXLE. NO BWS PART NUMBER EXISTS FOR THE AIR BAG
- 5) CONTROL BOX SHOWN IS ONLY CORRECT WITH THE HIGHLIFT OPTION. IF THERE IS NO HIGHLIFT OPTION THE CONTROL BOX P/N IS 402233. THIS BOX DOES NOT INCLUDE THE SECOND SOLENOID VALVE

#	DESCRIPTION	P/N	Q'TY
1	SERVICE GLAD HAND	40192	1
2	EMERGENCY GLAD HAND	40193	1
3	2S/1M ABS VALVE	401824	1
4	PRESSURE PROTECTION VALVE	40839	1
5	AIR GAUGE BWS	08307	1
6	HEIGHT CONTROL VALVE	40572	1
7	BRAKE POT	402051	4
8	MANUAL DUMP VALVE	63133	1
9	LARGE AIR TANK	401052	1
10	AIR HOSE BLACK 3/4 X 24"	40511	10
11	CONTROL BOX	402247	1
12	TAILGATE CYLINDER	04124	1
13	HIGHLIFT CYLINDER	402246	2
14	PILOT VALVE	40586	1
15	SUSPENSION AIR BAG	(NOTE 4)	4

2	SWRS	15/08/17	UPDATED PILOT VALVE SYMBOL			
1	SWRS	15/05/15	UPDATED COMPONENTS TO HIGH LIFT OPTION AND LAYOUT	SWRS		
0	LCH	2014/08/07	INITIAL ISSUE - MODIFIED FROM PS2A211CX.	SWRS		
REV.	BY	DATE	DESCRIPTION	CHK'D		
<p>BWS Manufacturing Ltd. 10 MONTANA ST. CENTREVILLE, N.B. CANADA E7K 3E9 PH: (506) 276-4567 FAX: (506) 276-4380</p>						
DRAWN BY	DATE	SCALE	SHT	MODEL	DWG. No.	REV
L. HUNTER	2014/08/07	1/2"=1'-0"	1 OF 1	27DT2X	PS2A211CX-HAL	2
		UNIT		2 AXLE, AIR RIDE DUMP TRAILER W/ HALDEX		
		TITLE		2S/1M, 1 AIR TANK, AIR CYLINDER, OPTIONAL HIGHLIFT		
				AIR SCHEMATIC		

FRONT OF TRAILER



DUMP TRAILER

37DT2X

REV.1, PS3A212CAX-HAL

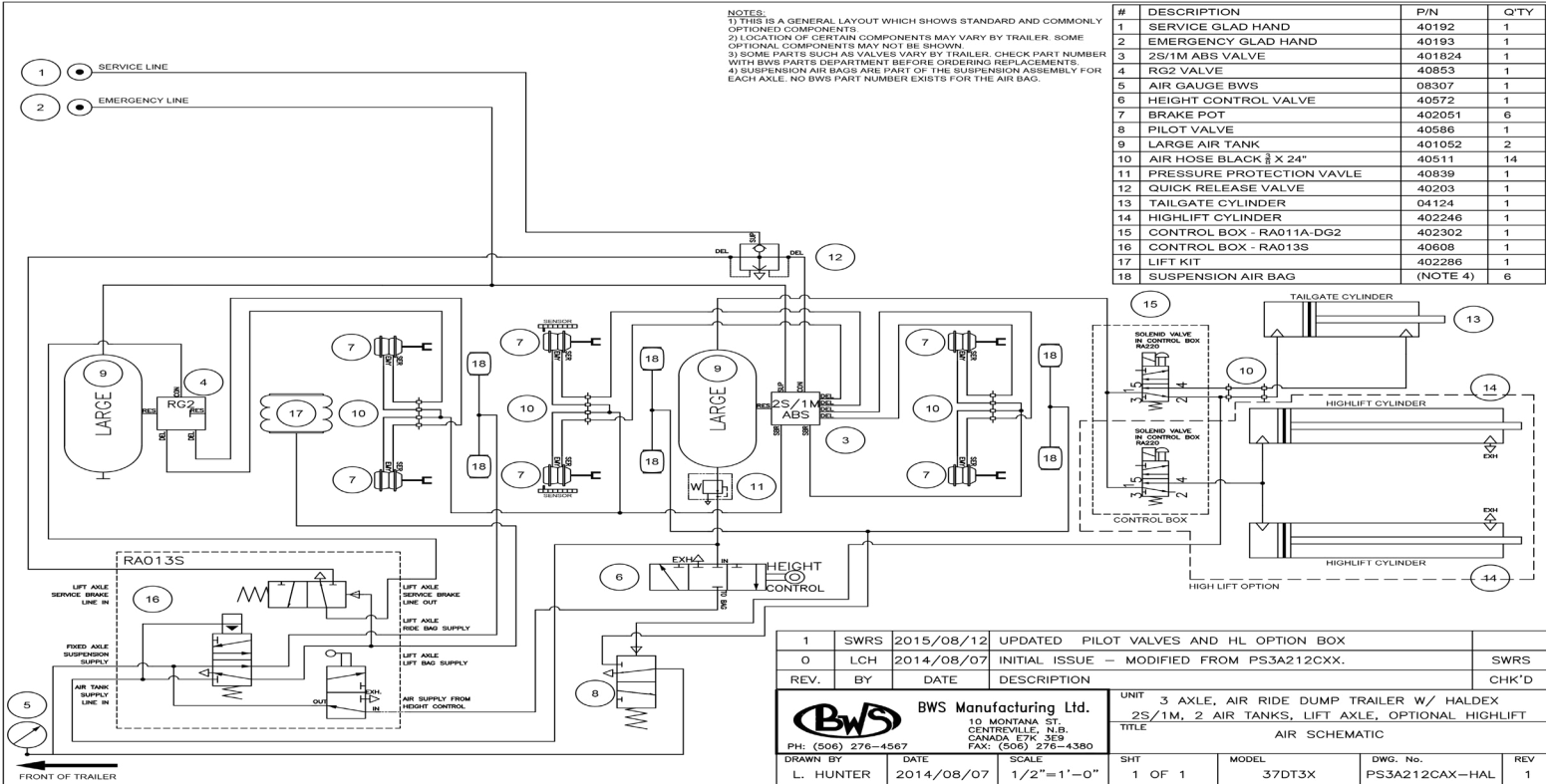

#	DESCRIPTION	P/N	Q'TY
1	SERVICE GLAD HAND	40192	1
2	EMERGENCY GLAD HAND	40193	1
3	2S/1M ABS VALVE	401824	1
4	RG2 VALVE	40853	1
5	AIR GAUGE BWS	08307	1
6	HEIGHT CONTROL VALVE	40572	1
7	BRAKE POT	402051	6
8	PILOT VALVE	40586	1
9	LARGE AIR TANK	401052	2
10	AIR HOSE BLACK 3/4" X 24"	40511	14
11	PRESSURE PROTECTION VALVE	40839	1
12	QUICK RELEASE VALVE	40203	1
13	TAILGATE CYLINDER	04124	1
14	HIGHLIFT CYLINDER	402246	1
15	CONTROL BOX - RA011A-DG2	402302	1
16	CONTROL BOX - RA013S	40608	1
17	LIFT KIT	402286	1
18	SUSPENSION AIR BAG (NOTE 4)		6

1	SWRS	2015/08/12	UPDATED	PILOT VALVES AND HL OPTION BOX	
0	LCH	2014/08/07	INITIAL ISSUE -	MODIFIED FROM PS3A212CXX.	SWRS
REV.	BY	DATE	DESCRIPTION		CHK'D
 BWS Manufacturing Ltd. 10, MONTANA ST. CENTREVILLE, N.B. CANADA E7K 3E9 PH: (506) 276-4567 FAX: (506) 276-4380					
DRAWN BY				SCALE	SHT
L. HUNTER				1/2"=1'-0"	1 OF 1
DATE				MODEL	DWG. No.
2014/08/07				37DT3X	PS3A212CAX-HAL
UNIT				DESCRIPTION	REV
3 AXLE, AIR RIDE DUMP TRAILER W/ HALDEX				2S/1M, 2 AIR TANKS, LIFT AXLE, OPTIONAL HIGHLIFT	1
TITLE				AIR SCHEMATIC	



ET & TAG

ET2X, ART, ANR & NTT (2 axle, air suspension)

REV.0, PS2A211TR-HAL

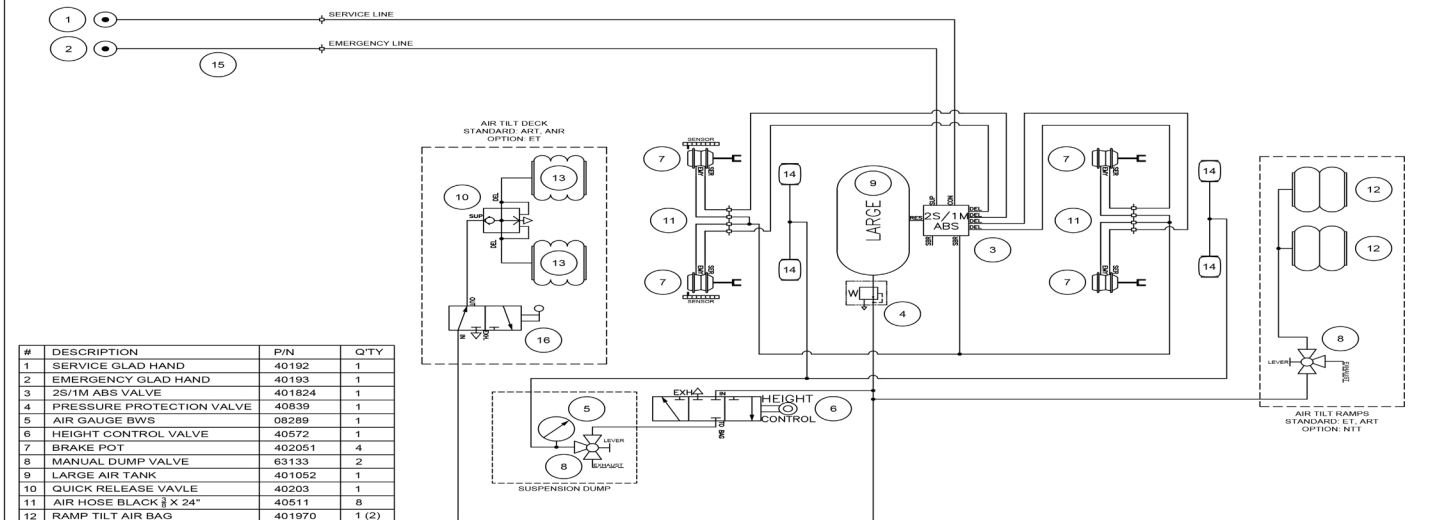

#	DESCRIPTION	P/N	QTY
1	SERVICE GLAD HAND	40192	1
2	EMERGENCY GLAD HAND	40193	1
3	2S/1M ABS VALVE	401824	1
4	PRESSURE PROTECTION VALVE	40839	1
5	AIR GAUGE BWS	08289	1
6	HEIGHT CONTROL VALVE	40572	1
7	BRAKE POT	402051	4
8	MANUAL DUMP VALVE	63133	2
9	LARGE AIR TANK	401052	1
10	QUICK RELEASE VALVE	40203	1
11	AIR HOSE BLACK 3/4 X 24"	40511	8
12	RAMP TILT AIR BAG	401970	1 (2)
13	DECK TILT AIR BAG	40383	1 (2,4)
14	SUSPENSION AIR BAG (NOTE 5)		6
15	AIR HOSE BLACK 1/2 X 50"	401231	2
16	AIR CONTROL VALVE	40516	1

NOTE:

- THIS IS A GENERAL LAYOUT FOR EQUIPMENT AND TAG-ALONG TRAILERS WHICH SHOWS STANDARD AND COMMONLY OPTIONED COMPONENTS.
- LOCATION OF CERTAIN COMPONENTS MAY VARY BY TRAILER. SOME OPTIONAL COMPONENTS MAY NOT BE SHOWN.
- NUMBER OF BAGS ON TILT DECK AND RAMPS VARY BY TRAILER.
- SOME PARTS SUCH AS VALVES VARY BY TRAILER. CHECK PART NUMBER WITH BWS PARTS DEPARTMENT BEFORE ORDERING REPLACEMENTS.
- SUSPENSION AIR BAGS VARY BY TRAILER MODEL BASED ON LOAD CAPACITY AND RIDE HEIGHT.
- QUANTITIES IN BRACKETS ARE ALTERNATIVE AIR BAG CONFIGURATIONS.
- THE 50" BLACK AIR HOSES CONNECTED TO THE GLAD HANDS ARE ONLY USED ON TAG TRAILERS.



REV.	BY	DATE	DESCRIPTION	CHK'D																
0	LCH	2014/07/24	INITIAL ISSUE - MODIFIED FROM PS2A211TX-HAL.																	
<table border="1" style="width:100%; border-collapse: collapse;"> <tr> <td style="width:15%; text-align: center;">BWS</td> <td style="width:45%;"> BWS Manufacturing Ltd. 10 MONTANA ST. CENTREVILLE, N.B. CANADA E7K 3E9 PH: (506) 276-4567 FAX: (506) 276-4360 </td> <td style="width:20%;"> UNIT 2 AXLE AIR RIDE TRAILER W/ HALDEX ABS 2S/1M ABS, 2 TANKS, DECK TILT, TILT RAMPS </td> <td style="width:20%;"></td> </tr> <tr> <td colspan="4" style="text-align: center;">TITLE AIR SCHEMATIC</td> </tr> <tr> <td> DRAWN BY L. HUNTER </td> <td> DATE 2014/07/24 </td> <td> SCALE 1/2"=1'-0" </td> <td> SHT 1 OF 1 </td> </tr> <tr> <td> MODEL ET & TAGS </td> <td> DWG. No. PS2A211TR-HAL </td> <td> REV 0 </td> <td></td> </tr> </table>					BWS	BWS Manufacturing Ltd. 10 MONTANA ST. CENTREVILLE, N.B. CANADA E7K 3E9 PH: (506) 276-4567 FAX: (506) 276-4360	UNIT 2 AXLE AIR RIDE TRAILER W/ HALDEX ABS 2S/1M ABS, 2 TANKS, DECK TILT, TILT RAMPS		TITLE AIR SCHEMATIC				DRAWN BY L. HUNTER	DATE 2014/07/24	SCALE 1/2"=1'-0"	SHT 1 OF 1	MODEL ET & TAGS	DWG. No. PS2A211TR-HAL	REV 0	
BWS	BWS Manufacturing Ltd. 10 MONTANA ST. CENTREVILLE, N.B. CANADA E7K 3E9 PH: (506) 276-4567 FAX: (506) 276-4360	UNIT 2 AXLE AIR RIDE TRAILER W/ HALDEX ABS 2S/1M ABS, 2 TANKS, DECK TILT, TILT RAMPS																		
TITLE AIR SCHEMATIC																				
DRAWN BY L. HUNTER	DATE 2014/07/24	SCALE 1/2"=1'-0"	SHT 1 OF 1																	
MODEL ET & TAGS	DWG. No. PS2A211TR-HAL	REV 0																		



ET & TAG

ET3X, ART, ANR & NTT (3 axle, air suspension)
REV.0, PS3A212TR-HAL

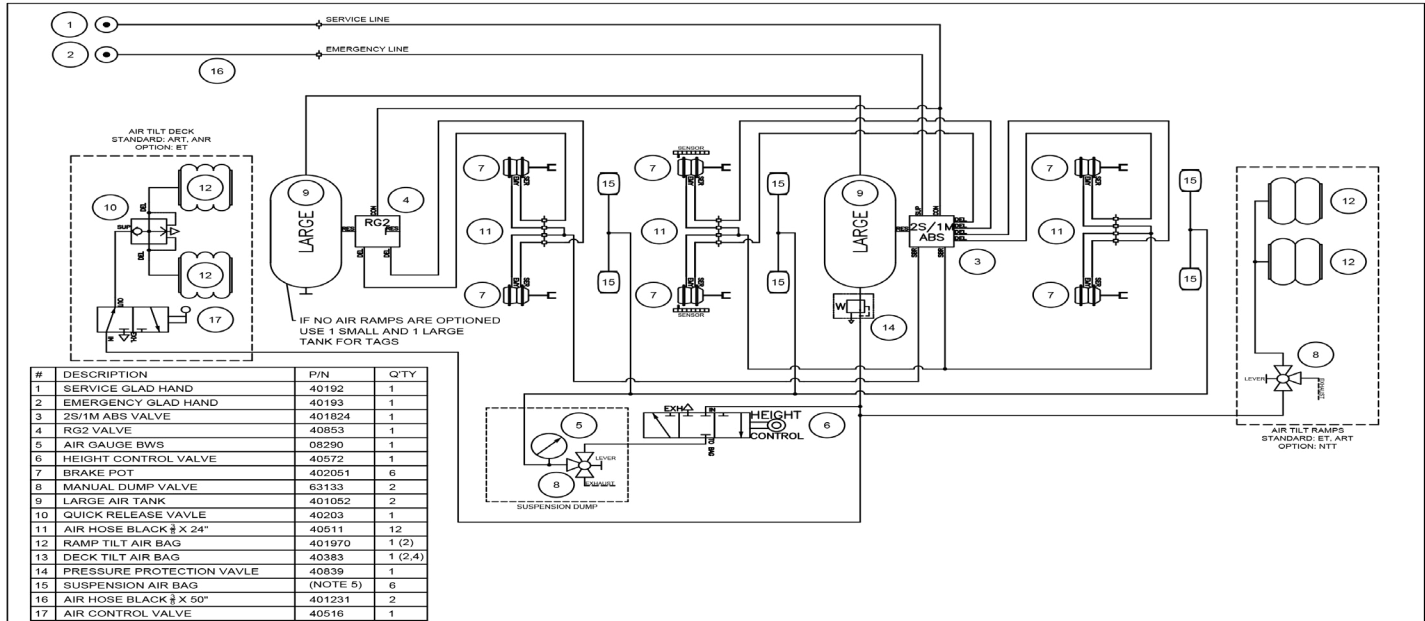

NOTES:
1) THIS IS A GENERAL LAYOUT FOR EQUIPMENT AND TAG-ALONG TRAILERS WHICH SHOWS STANDARD AND COMMONLY OPTIONED COMPONENTS.
2) LOCATION OF CERTAIN COMPONENTS MAY VARY BY TRAILER. SOME OPTIONAL COMPONENTS MAY NOT BE SHOWN.
3) NUMBER OF BAGS ON TILT DECK AND RAMPS VARY BY TRAILER.
4) SOME PARTS SUCH AS VALVES VARY BY TRAILER. CHECK PART NUMBER WITH BWS PARTS DEPARTMENT BEFORE ORDERING REPLACEMENTS.
5) SUSPENSION AIR BAGS VARY BY TRAILER MODEL BASED ON LOAD CAPACITY AND RIDE HEIGHT.
6) QUANTITIES IN BRACKETS ARE ALTERNATIVE AIR BAG CONFIGURATIONS.
7) THE 50" BLACK AIR HOSES CONNECTED TO THE GLAD HANDS ARE ONLY USED ON TAG TRAILERS.

FRONT OF TRAILER

REV.	LCH	DATE	DESCRIPTION	CHK'D		
0	LCH	2014/08/07	INITIAL ISSUE - MODIFIED FROM PS3A212TX-HAL.			
BWS BWS Manufacturing Ltd. 10 MONTANA ST. CENTREVILLE, N.S. CANADA E7K 3E9 PH: (506) 276-4567 FAX: (506) 276-4380				UNIT 3 AXLE AIR RIDE TRAILER W/ HALDEX ABS 2S/1M ABS, 2 TANKS, DECK TILT, TILT RAMPS TITLE AIR SCHEMATIC		
DRAWN BY	DATE	SCALE	SHT	MODEL	DWG. No.	REV
L. HUNTER	2014/08/07	1/2"=1'-0"	1 OF 1	ET & TAGS	PS3A212TR-HAL	0



TAG

ART, ANR & NTT (2 axle, spring suspension)

REV.0, PS2S211TR-HAL

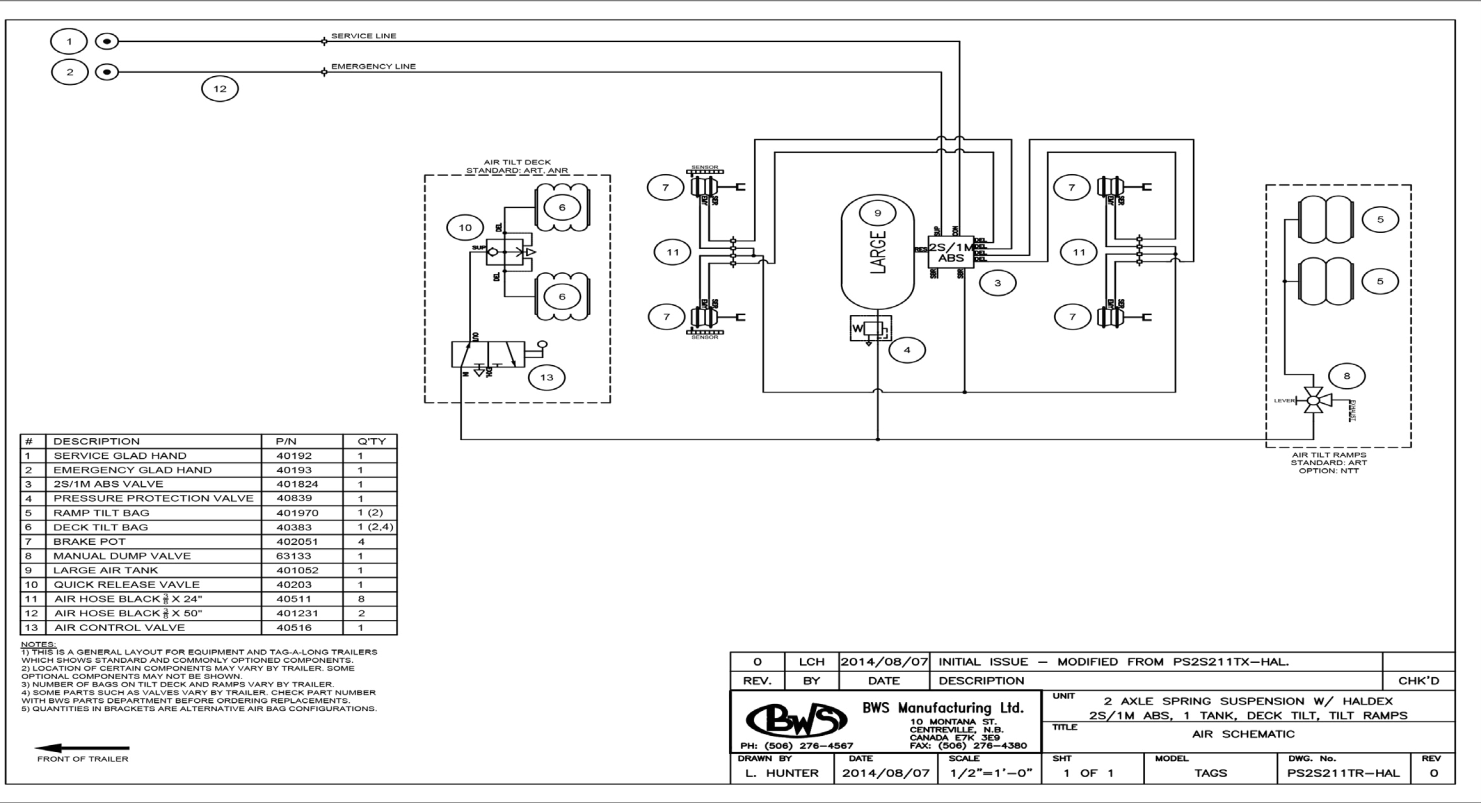

#	DESCRIPTION	P/N	Q'TY
1	SERVICE GLAD HAND	40192	1
2	EMERGENCY GLAD HAND	40193	1
3	2S/1M ABS VALVE	401824	1
4	PRESSURE PROTECTION VALVE	40839	1
5	RAMP TILT BAG	401970	1 (2)
6	DECK TILT BAG	40383	1 (2,4)
7	BRAKE POT	402051	4
8	MANUAL DUMP VALVE	63133	1
9	LARGE AIR TANK	401052	1
10	QUICK RELEASE VALVE	40203	1
11	AIR HOSE BLACK 3/8" X 24"	40511	8
12	AIR HOSE BLACK 3/8" X 50"	401231	2
13	AIR CONTROL VALVE	40516	1

NOTES:
 1) THIS IS A GENERAL LAYOUT FOR EQUIPMENT AND TAG-ALONG TRAILERS WHICH SHOWS STANDARD AND COMMONLY OPTIONED COMPONENTS.
 2) LOCATION OF CERTAIN COMPONENTS MAY VARY BY TRAILER. SOME OPTIONAL COMPONENTS MAY NOT BE SHOWN.
 3) NUMBER OF BAGS ON TILT DECK AND RAMPS VARY BY TRAILER.
 4) SOME PARTS SUCH AS VALVES VARY BY TRAILER. CHECK PART NUMBER WITH BWS PARTS DEPARTMENT BEFORE ORDERING REPLACEMENTS.
 5) QUANTITIES IN BRACKETS ARE ALTERNATIVE AIR BAG CONFIGURATIONS.

← FRONT OF TRAILER

0	LCH	2014/08/07	INITIAL ISSUE — MODIFIED FROM PS2S211TX-HAL.	
REV.	BY	DATE	DESCRIPTION	CHK'D
			UNIT	2 AXLE SPRING SUSPENSION W/ HALDEX
			TITLE	2S/1M ABS, 1 TANK, DECK TILT, TILT RAMPS
AIR SCHEMATIC				
PH. (506) 276-4567		DATE	SCALE	SHT
L. HUNTER		2014/08/07	1/2"=1'-0"	1 OF 1
		MODEL	DWG. No.	REV
		TAGS	PS2S211TR-HAL	0



TAG

ART, ANR & NTT (3 axle, spring suspension)

REV.0, PS3S212TR-HAL

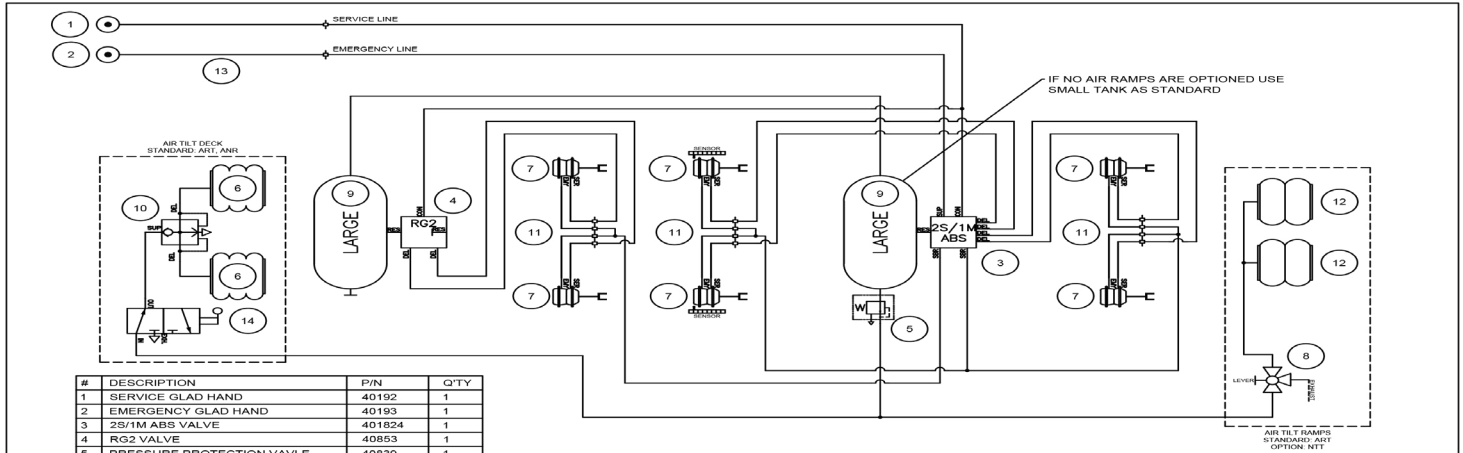

#	DESCRIPTION	P/N	QTY
1	SERVICE GLAD HAND	40192	1
2	EMERGENCY GLAD HAND	40193	1
3	2S/1M ABS VALVE	401824	1
4	RG2 VALVE	40853	1
5	PRESSURE PROTECTION VAVLE	40839	1
6	DECK TILT AIR BAG	40383	1 (2,4)
7	BRAKE POT	402061	6
8	MANUAL DUMP VALVE	63133	2
9	LARGE AIR TANK	401052	2
10	QUICK RELEASE VAVLE	40203	1
11	AIR HOSE BLACK 3/4 X 24"	40511	12
12	RAMP TILT AIR BAG	401970	1 (2)
13	AIR HOSE BLACK 3/4 X 50"	401231	2
14	AIR CONTROL VALVE	40516	1

NOTES:

- 1) THIS IS A GENERAL LAYOUT FOR EQUIPMENT AND TAG-A-LONG TRAILERS WHICH SHOWS STANDARD AND COMMONLY OPTIONED COMPONENTS.
- 2) LOCATION OF CERTAIN COMPONENTS MAY VARY BY TRAILER. SOME OPTIONAL COMPONENTS MAY NOT BE SHOWN.
- 3) NUMBER OF BAGS ON TILT DECK AND RAMPS VARY BY TRAILER.
- 4) SOME PARTS SUCH AS VALVES VARY BY TRAILER. CHECK PART NUMBER WITH BWS PARTS DEPARTMENT BEFORE ORDERING REPLACEMENTS.
- 5) QUANTITIES IN BRACKETS ARE ALTERNATIVE AIR BAG CONFIGURATIONS.
- 6) THE 50" BLACK AIR HOSES CONNECTED TO THE GLAD HANDS ARE ONLY USED ON TAG TRAILERS.

← FRONT OF TRAILER

0	LCH	2014/08/07	INITIAL ISSUE - MODIFIED FROM PS3S212TX-HAL		
REV.	BY	DATE	DESCRIPTION	CHK'D	
			UNIT	3 AXLE SPRING SUSPENSION W/ HALDEX	
			TITLE	2S/1M ABS, 2 TANKS, DECK TILT, TILT RAMPS	
			AIR SCHEMATIC		
		BWS Manufacturing Ltd. 10 MONTANA ST. CENTREVILLE, N.B. CANADA E7K 3E9 FAX: (506) 276-4380			
DRAWN BY	DATE	SCALE	SHT	MODEL	DWG. No.
L. HUNTER	2014/08/07	1/2"=1'-0"	1 OF 1	TAGS	PS3S212TR-HAL
					REV
					0



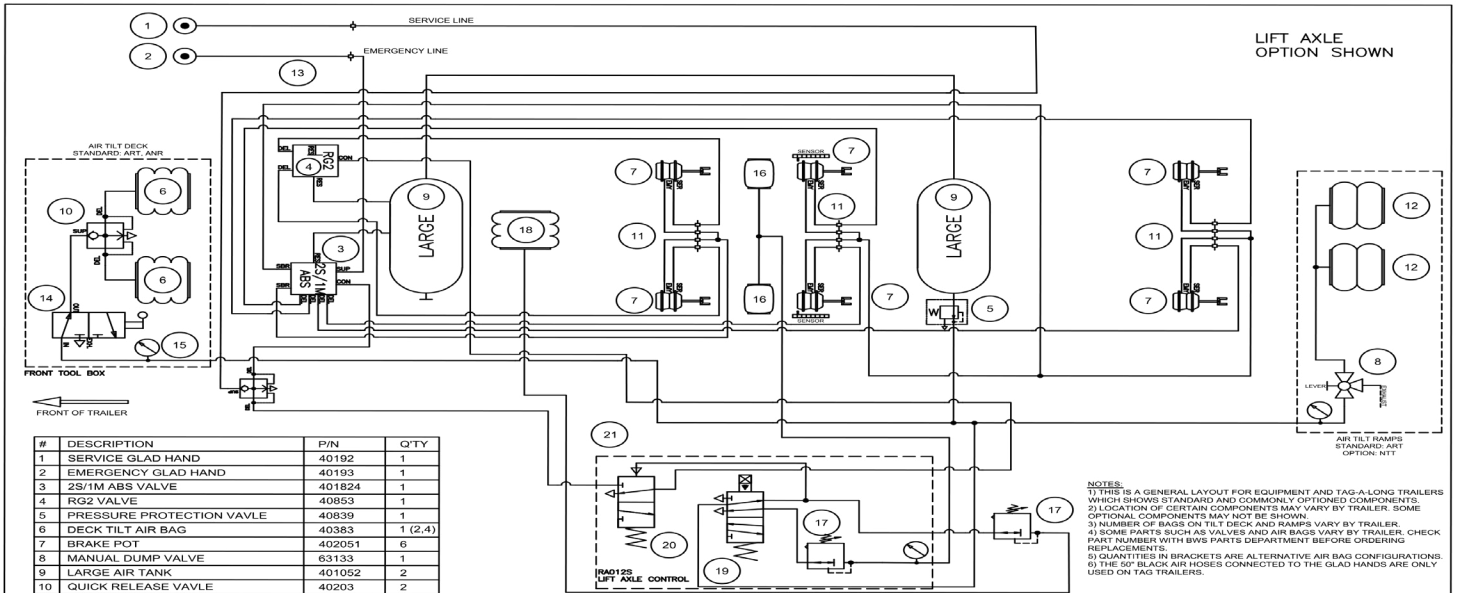

#	DESCRIPTION	P/N	QTY
1	SERVICE GLAD HAND	40192	1
2	EMERGENCY GLAD HAND	40193	1
3	2S/1M ABS VALVE	401824	1
4	RG2 VALVE	40853	1
5	PRESSURE PROTECTION VAVLE	40839	1
6	DECK TILT AIR BAG	40383	1 (2,4)
7	BRAKE POT	402051	6
8	MANUAL DUMP VALVE	63133	1
9	LARGE AIR TANK	401052	2
10	QUICK RELEASE VAVLE	40203	2
11	AIR HOSE BLACK 3/4" X 24"	40511	12
12	RAMP TILT AIR BAG	401970	1 (2)
13	AIR HOSE BLACK 3/4" X 50"	401231	2
14	AIR CONTROL VALVE	40516	1
15	AIR GAGE BWS	08290	1-3
16	SUSPENSION BAGS	NOTE 4	2
17	PRESSURE REGULATOR VALVE	401457	2
18	LIFT AXLE BAG	NOTE 4	1
19	LIFT AXLE SOLENOID VALVE	402422	1
20	PILOT VALVE	40586	1
21	CONTROL BOX	40829	1

NOTES:
 1) THIS IS A GENERAL LAYOUT FOR EQUIPMENT AND TAG-A-LONG TRAILERS WHICH SHOWS STANDARD AND COMMONLY OPTIONED COMPONENTS.
 2) LOCATION OF CERTAIN COMPONENTS MAY VARY BY TRAILER. SOME OPTIONAL COMPONENTS MAY NOT BE SHOWN.
 3) NUMBER OF BAGS ON TILT DECK AND RAMPS VARY BY TRAILER.
 4) SOME PARTS SUCH AS VALVES AND AIR BAGS VARY BY TRAILER. CHECK PART NUMBER WITH BWS PARTS DEPARTMENT BEFORE ORDERING REPLACEMENTS.
 5) QUANTITIES IN BRACKETS ARE ALTERNATIVE AIR BAG CONFIGURATIONS.
 6) THE 50' BLACK AIR HOSES CONNECTED TO THE GLAD HANDS ARE ONLY USED ON TAG TRAILERS.

2	WJD	2016/04/27	UPDATED LAYOUT.		
1	SWRS	2015/06/15	IMPROVED LAYOUT AND ADDED ANOTHER REGULATOR		WJD
0	SWRS	2015/06/05	INITIAL ISSUE - MODIFIED FROM PS3S212TX-HAL.		SWRS
REV.	BY	DATE	DESCRIPTION		CHK'D
BWS Manufacturing Ltd. 10 MONTANA ST. CENTREVILLE, N.B. CANADA L7R 3E9 FAX: (506) 276-4380					
DRAWN BY			DATE	SCALE	SHT
S. SAUNDERS			2015/06/05	1/2"=1'-0"	1 OF 1
TITLE			MODEL		
LIFT AXLE (1) AIR (2) SPRING SUSPENSION W/ HALDEX 2S/1M ABS, 2 TANKS, DECK TILT, TILT RAMPS			TAGS		
AIR SCHEMATIC			DWG. No.		
			PS3SA212A-HAL		
			REV		
			2		

8.0 ELECTRICAL SCHEMATICS

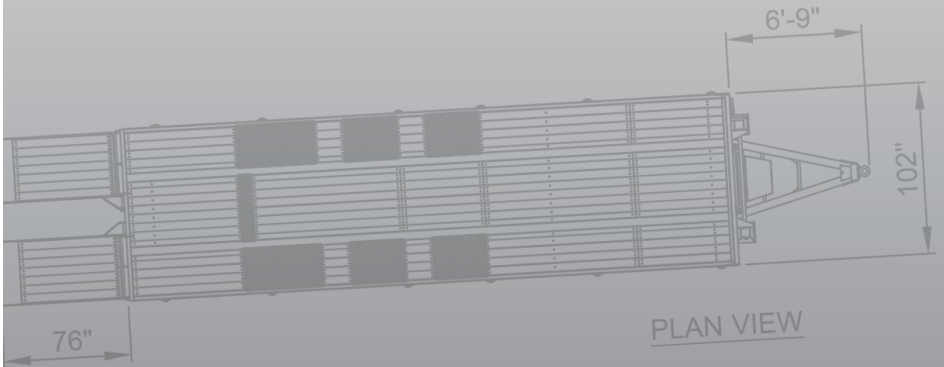

ELECTRICAL SCHEMATICS

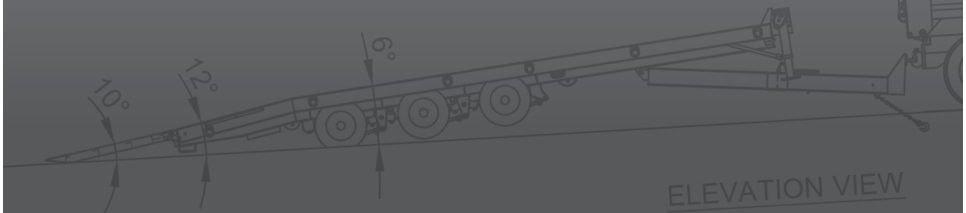

JEEP

20JD1X, 40JD2XWL, 60JD3X

REV.1, WS021

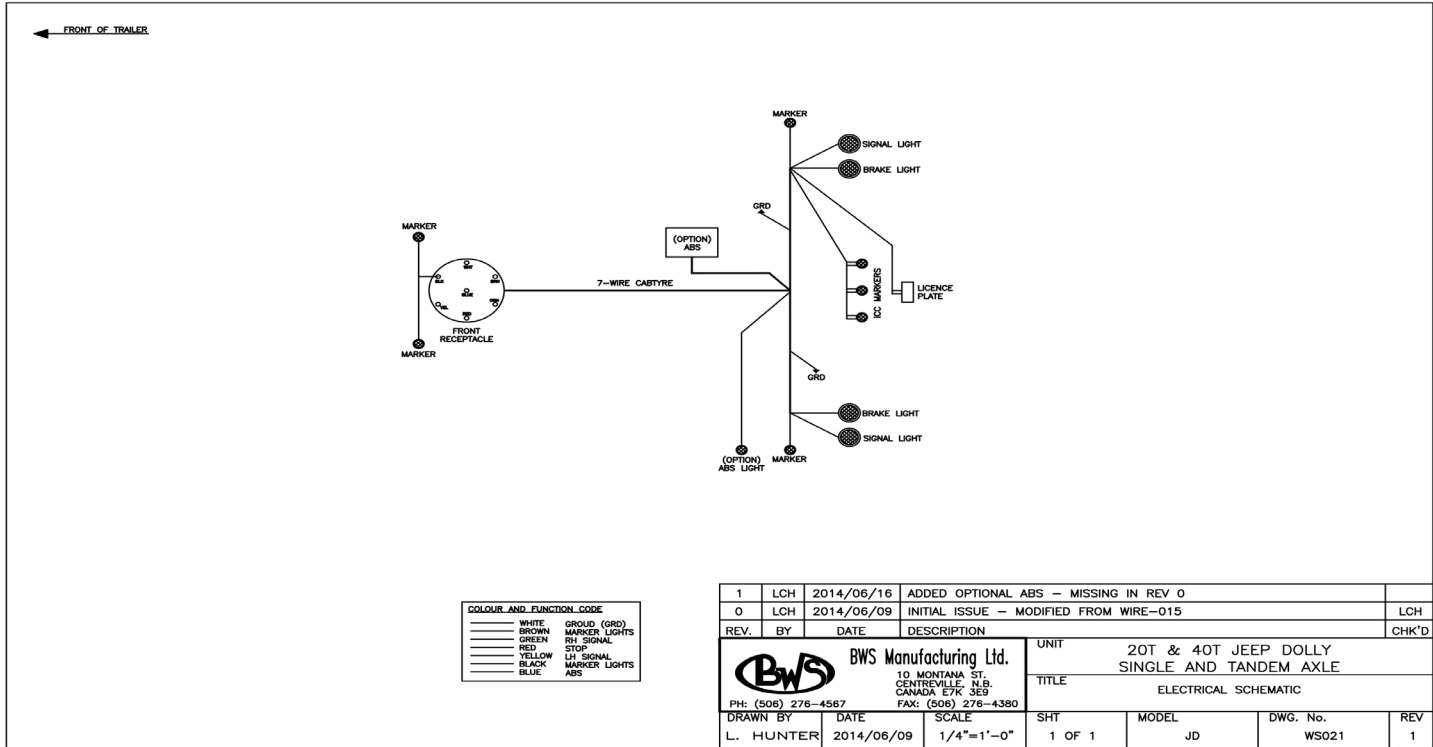

COLOUR AND FUNCTION CODE	
— WHITE	GROUND (GRD)
— BROWN	MARKER LIGHTS
— GREEN	RH SIGNAL
— RED	STOP
— YELLOW	LH SIGNAL
— BLACK	MARKER LIGHTS
— BLUE	ABS

1	LCH	2014/06/16	ADDED OPTIONAL ABS - MISSING IN REV 0					
0	LCH	2014/06/09	INITIAL ISSUE - MODIFIED FROM WIRE-015	LCH				
REV.	BY	DATE	DESCRIPTION	CHK'D				
		BWS Manufacturing Ltd. 19 MONTANA ST. CENTREVILLE, N.B. CANADA E7K 3E9 PH: (506) 276-4567 FAX: (506) 276-4380		UNIT 20T & 40T JEEP DOLLY SINGLE AND TANDEM AXLE				
DRAWN BY			DATE	SCALE	SHT	MODEL	DWG. No.	REV
L. HUNTER			2014/06/09	1/4"=1'-0"	1 OF 1	JD	WS021	1
TR:								UNITS

MACHINE SHOP:

DUMP TRAILER WITH OPTIONAL LIFT SOLENIOD

27DT2X, 37DT3X,

Rev. 1, WS018

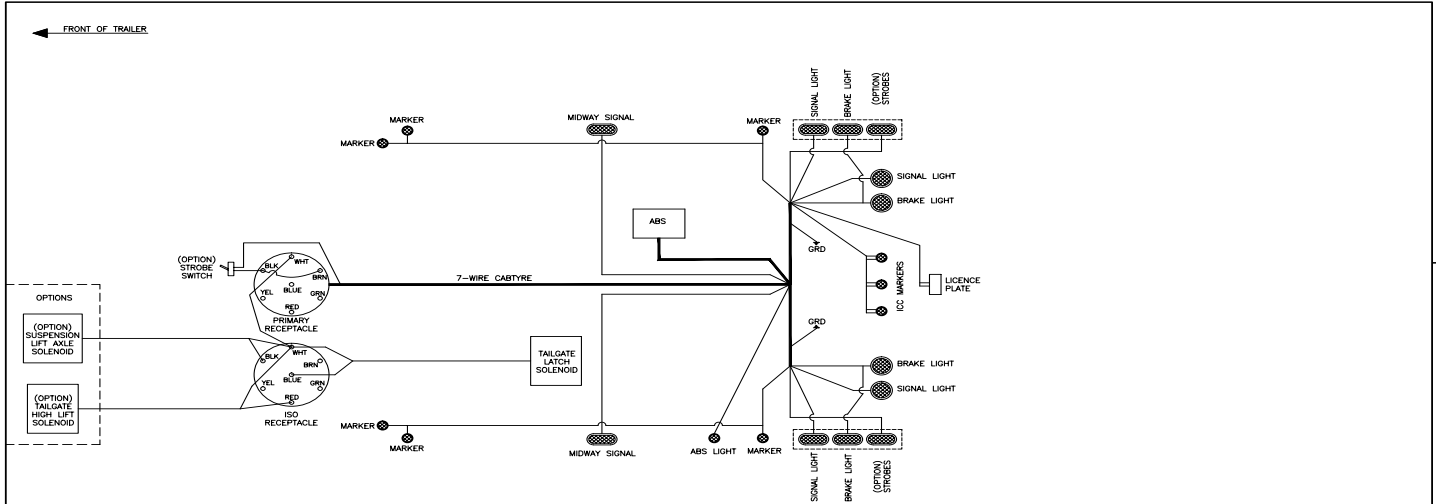

PRIMARY RECEPTACLE COLOUR CODE

WHITE	GROUND (GRD)
BROWN	MARKER LIGHTS
GREEN	RH SIGNAL
RED	LH SIGNAL
YELLOW	STROBE LIGHTS
BLACK	ABS
BLUE	ABS

AUXILIARY RECEPTACLE COLOUR CODE

WHITE	GROUND (GRD)
BROWN	LIFT AXLE
GREEN	TAILGATE LIFT
RED	TAILGATE LATCH
YELLOW	TAILGATE LATCH
BLACK	TAILGATE LATCH
BLUE	TAILGATE LATCH

1	LCH	2014/06/16	MODIFIED LIGHT NAMES FOR MANUALS	
0	LCH	2014/06/09	INITIAL ISSUE - MODIFIED FROM WS017	
REV.	BY	DATE	DESCRIPTION	CHK'D

	BWS Manufacturing Ltd. 10 MONTANA ST. CENTREVILLE, N.B. CANADA E7K 3E9 PH: (506) 276-4567 FAX: (506) 276-4380		UNIT DUMP TRAILER W/ OPTIONAL LIFT SOLENIODS	
			TITLE ELECTRICAL SCHEMATIC	

DRAWN BY	DATE	SCALE	SHT	MODEL	DWG. No.	REV
L. HUNTER	2014/06/09	1/4"=1'-0"	1 OF 1	DT	WS018	1

TR: _____ UNITS

MACHINE SHOP:



HIGHWAY AND EQUIPMENT TRAILERS

53HF3X, 48ET3X, 48HD2X

Rev. 1, WS020

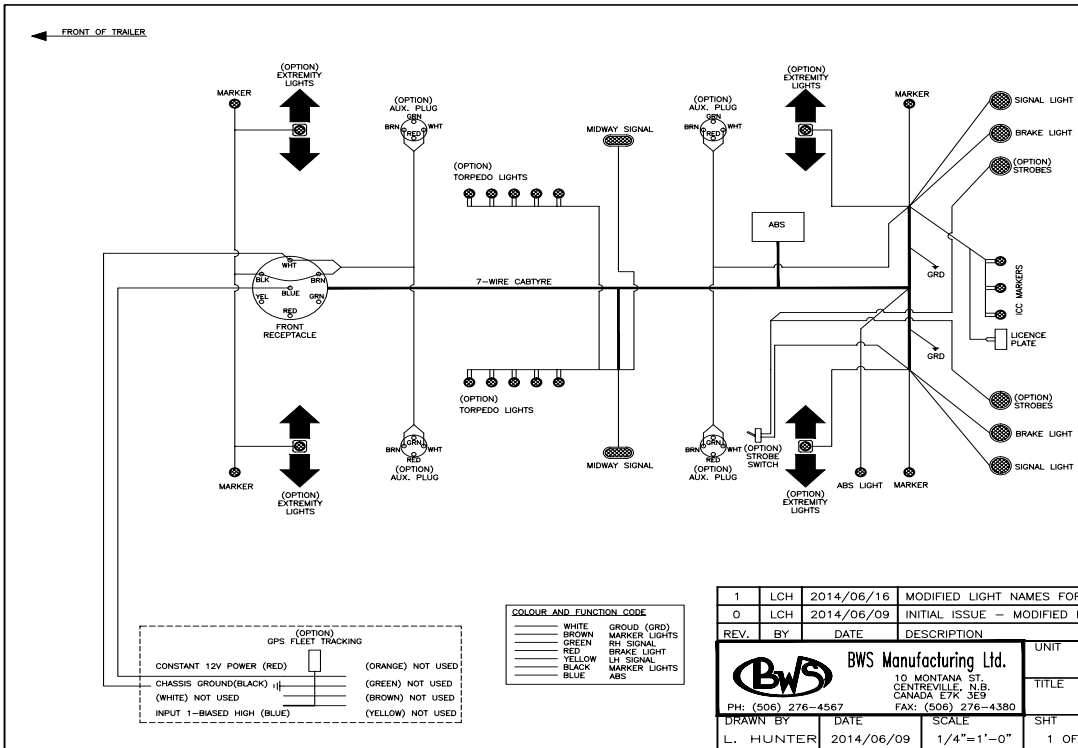

1	LCH	2014/06/16	MODIFIED LIGHT NAMES FOR MANUALS			
0	LCH	2014/06/09	INITIAL ISSUE - MODIFIED FROM WIRE-040			
REV.	BY	DATE	DESCRIPTION	CHK'D		
 BWS Manufacturing Ltd. 10 MONTANA ST. CENTREVILLE, N.B. CANADA E7K 3E9 PH: (506) 276-4567 FAX: (506) 276-4380			UNIT HIGHWAY & EQUIPMENT TRAILERS W/ OPTIONAL GPS TITLE ELECTRICAL SCHEMATIC			
DRAWN BY	DATE	SCALE	SHT	MODEL	DWG. No.	REV
L. HUNTER	2014/06/09	1/4"=1'-0"	1 OF 1	HF, HD, & ET	WS020	1
TR:						UNITS

MACHINE SHOP



LOGGING, SINGLE DROP TRAILER

ALL LD (ie. 53LD3X3T)

Rev. 2, WS022

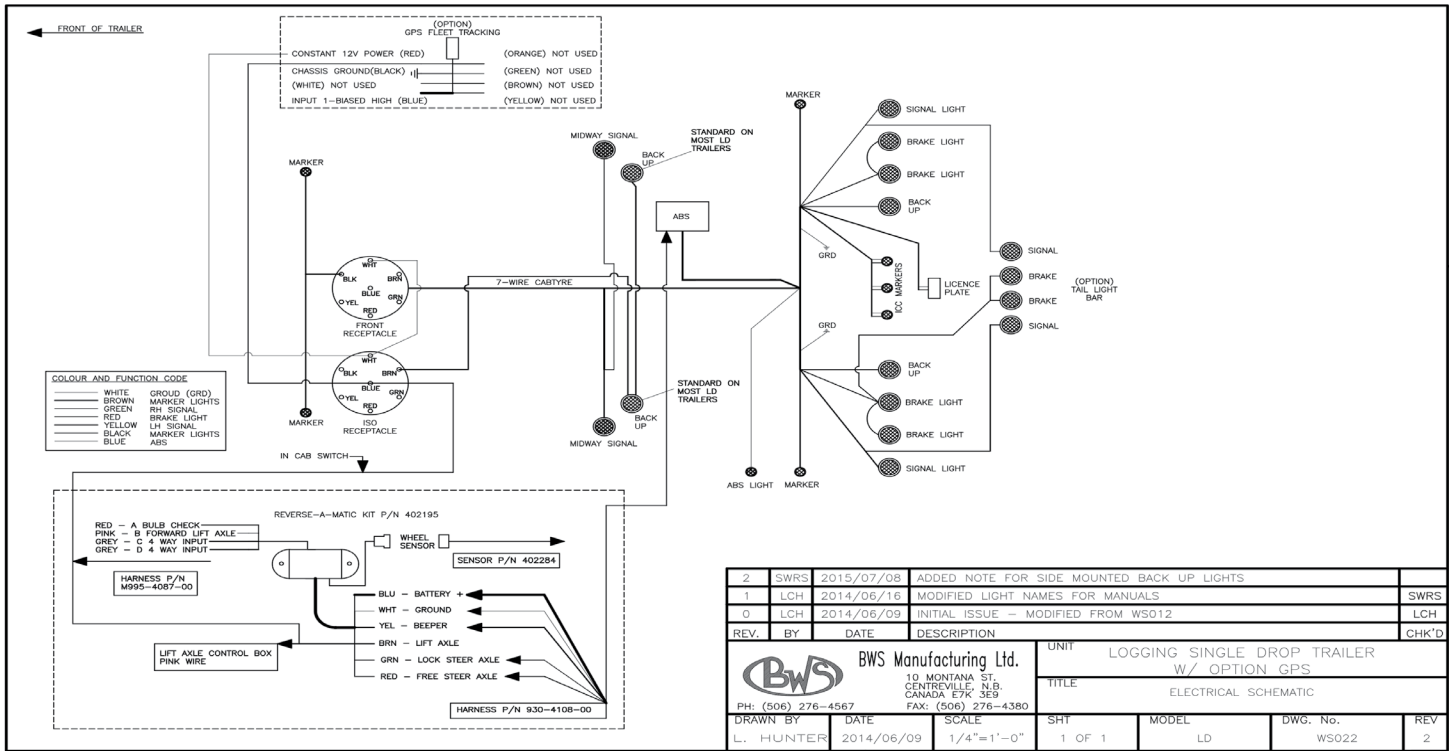

2	SWRS	2015/07/08	ADDED NOTE FOR SIDE MOUNTED BACK UP LIGHTS			
1	LCH	2014/06/16	MODIFIED LIGHT NAMES FOR MANUALS	SWRS		
0	LCH	2014/06/09	INITIAL ISSUE — MODIFIED FROM WS012	LCH		
REV.	BY	DATE	DESCRIPTION	CHK'D		
			BWS Manufacturing Ltd.	UNIT		
			10 MONTANA ST. CENTREVILLE, N.B. CANADA E7K 3E9	LOGGING SINGLE DROP TRAILER W/ OPTION GPS		
			PH: (506) 276-4567 FAX: (506) 276-4380	TITLE		
				ELECTRICAL SCHEMATIC		
DRAWN BY	DATE	SCALE	SHT	MODEL	DWG. No.	REV
L. HUNTER	2014/06/09	1/4"=1'-0"	1 OF 1	LD	WS022	2
TR:			—		UNITS	

MACHINE SHOP



LOGGING TRAILER, FLAT

ALL LOGGING FLATS (ie: 53LF4X5T)

Rev. 3, WS023

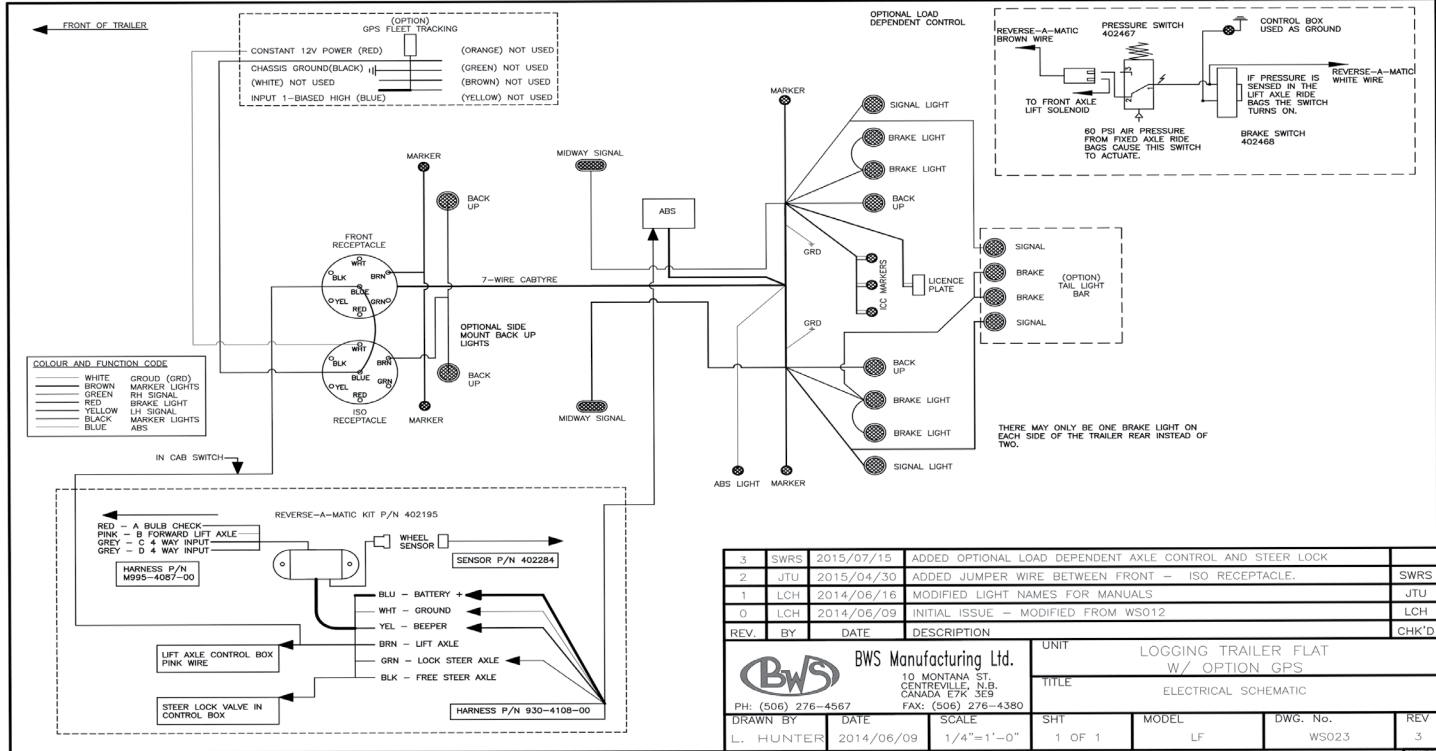

LOGGING B-TRAIN TRAILERS

37LBT3X, 27LBT2X

Rev. 1, WS024

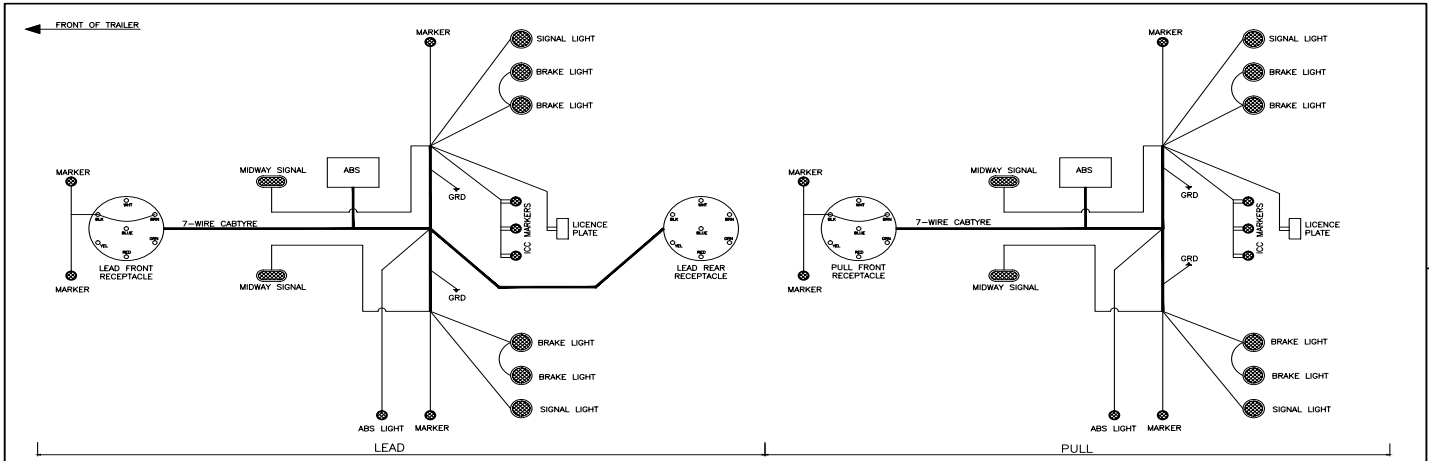

COLOUR AND FUNCTION CODE	
—	WHITE GROUND (GRD)
—	BROWN MARKER LIGHTS
—	GREEN RH SIGNAL
—	RED BRAKE LIGHT
—	YELLOW LH SIGNAL
—	BLACK MARKER LIGHTS
—	BLUE ABS

1	LCH	2014/06/16	MODIFIED LIGHT NAMES FOR MANUALS		
0	LCH	2014/06/09	INITIAL ISSUE — MODIFIED FROM WIRE-029 AND WIRE-031		
REV:	BY	DATE	DESCRIPTION	UNIT	CHK'D
			LOGGING B-TRAIN TRAILERS		
			ELECTRICAL SCHEMATIC		
BWS Manufacturing Ltd. 10 MONTANA ST. CENTREVILLE, N.B. CANADA E7K 3E9 PH: (506) 276-4567 FAX: (506) 276-4380					
DRAWN BY	DATE	SCALE	SHT	MODEL	DWG. No.
L. HUNTER	2014/06/09	1/4"=1'-0"	1 OF 1	LBT	WS024
					REV 1

TR: — UNITS

MACHINE SHOP:



10.0 CONTROL BOXES

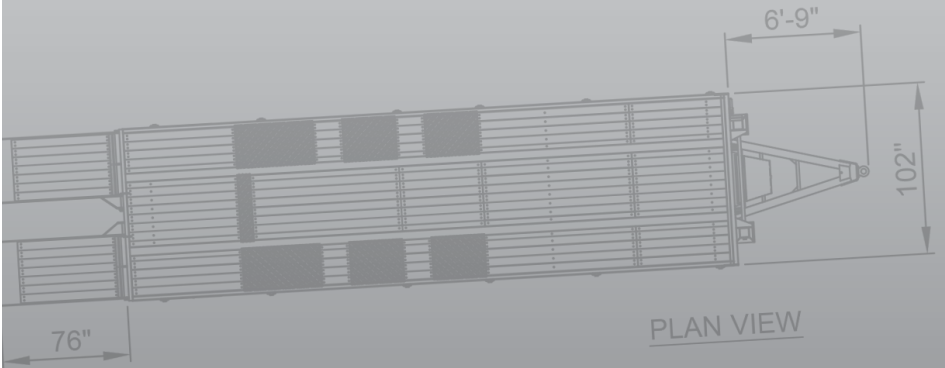

CONTROL BOXES

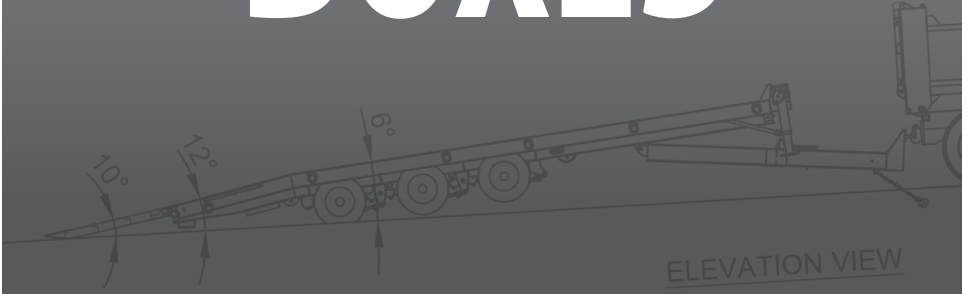
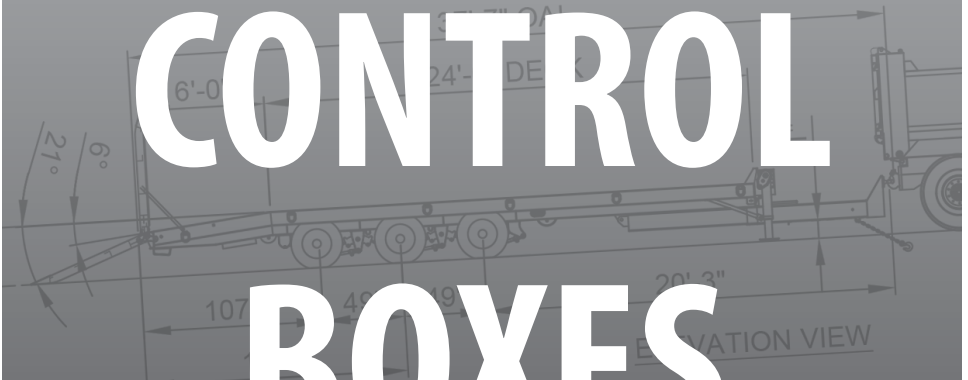

SUSPENSION DUMP / TAILGATE CONTROL (RA011-DG)

27DT



RA011A-DG Suspension Dump / Tailgate Control

S/N - 3521200

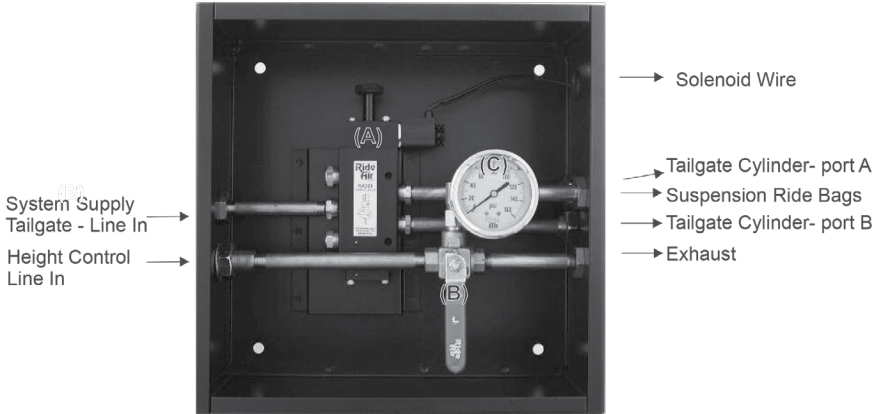

System Operation:

Suspension Dump: - To fill air suspension rotate red handle 90 degrees up to the right.
- To dump air suspension position red handle down as shown.

Tailgate Control: - To release the tailgate supply 12 VDC power to valve (A) or push the manual control knob down and twist to lock.
- Reverse operation to lock tailgate

Component List:

(A) - RA220 - Tailgate solenoid valve (B) - RA723-4 - 3 way ball valve
(C) - RA325CL - Liquid filled gauge (D) - RA001A - Powder coated steel box
(E) - RA002 - Rubber latch (not shown)

SUSPENSION TAILGATE CONTROL (RA011A-DG3)

37DT



RA011A-DG3 Suspension / Tailgate Control

S/N - 1201300

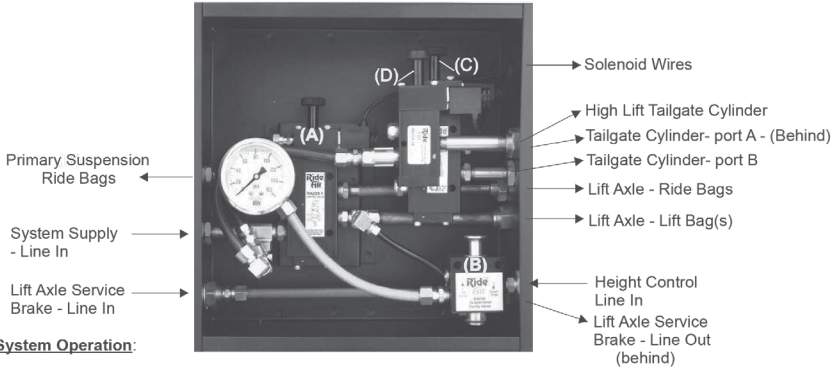

System Operation:

Suspension Dump: - To fill air suspension push control knob (B) down (as shown).
- To dump air suspension lift control knob (B) up.

Lift Axle Control: - Down - With the manual control knob (A) up and electric power off, the lift axle ride bags will fill to the pressure supplied by the height control valve.
- Up - Supply 12 volt DC power to the solenoid (the manual control knob must be up) OR manually push control knob (A) down and twist to lock.

Tailgate Control: - To release the tailgate supply 12 VDC power to valve (C) or push the manual control knob down and twist to lock.
- Reverse operation to lock tailgate

High Lift Control: - To operate the high lift tailgate option supply 12 VDC to valve (D) or push the manual control knob down and twist to lock.
- Reverse operation to lower tailgate.

Component List:

(A) - RA220-1	- Lift Axle solenoid valve	(B) - RA030	- Dump valve
(C) - RA220	- Tailgate solenoid valve	(D) - RA220-34	- High Lift solenoid valve
(E) - RA325CL	- Liquid filled gauge	(F) - RA001A-BWS	- Powder coated steel box
(G) - RA002	- Rubber latch (not shown)		

SUSPENSION CONTROL (RA016SSA-21LS)

51LD4X5T ON 2016, 48LF4X5T NB V2016, 51LF4X5T NB V2016



RA016SSA-21LS Suspension Control

S/N -0000000

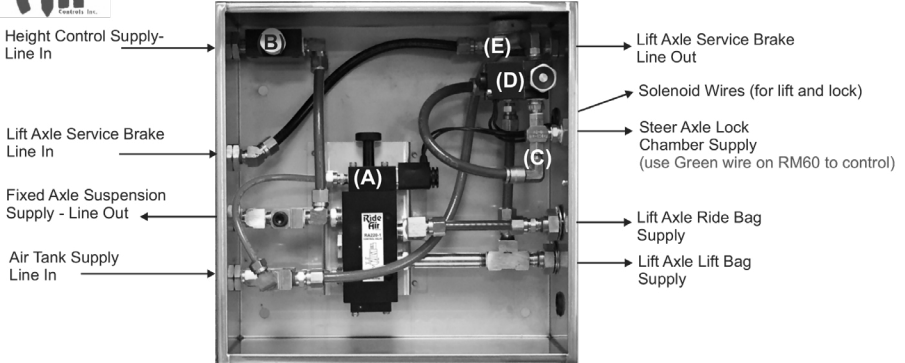

System Operation:

Suspension Dump: Pull out control knob (B), the suspension will exhaust. Push in to Fill.

Lift Axle Down: With the manual control knob (A) up, the steer/lift ride bags will fill to the system pressure.

Lift Axle Up: Supply 12 volt DC power to the solenoid (the manual control knob must be up) OR manually push the control knob down, rotate to lock.

Component List:

(A) - RA220-1 - Lift Axle Solenoid Valve
(B) - RA030 - Dump Valve
(C) - RA501 - Shuttle Valve
(D) - RA740MAC - Solenoid Valve N/C

(E) - RA510 - Pilot Valve
(F) - RA001BSR -Stainless steel box (only)

RA013 - DUAL - 3 DUAL SUSPENSION CONTROL

48LD4X4T NB 2017



RA013-Dual - 3 Dual Suspension Control

S/N -0231700

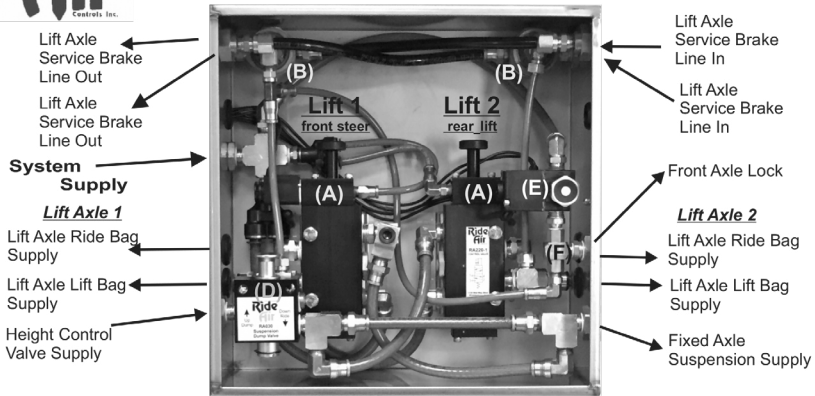

System Operation:

Suspension Dump: LIFT knob on valve (D) to dump all suspension ride bags. PUSH DOWN to fill.

Lift Axle Down: With the manual control knob up on Valve (A) and electric power off, the lift axle ride bags will fill to the system pressure.

Lift Axle Up: Supply 12 volt DC power to the solenoid (the knob must be up) OR manually push the control knob down on Control Valve (A) and twist to lock.

Component List:

(A) - RA220-1 - Lift axle solenoid valve
(B) - RA510 - Pilot valve
(C) - RA001BS-4- Stainless Box (only)

(D) - RA030 - Push Pull Dump valve
(E) - RA740MAC - NC solenoid
(F) - RA501 - Shuttle Valve

RA013S SUSPENSION CONTROL

53ET3XP, 46LF3X4T NS V2017, 48LF3X5T NB V2016, 30ART (AIR SUSP.)



RA013S Suspension Control

S/N - 2311100

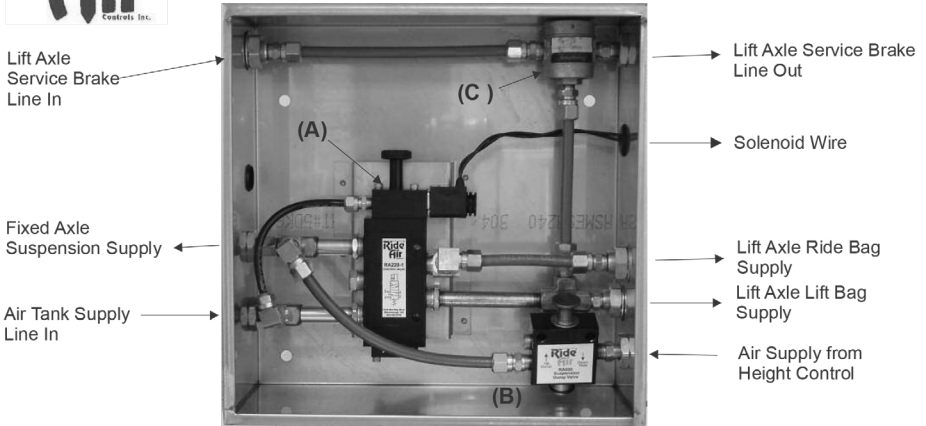

System Operation:

Suspension Dump: LIFT knob on RA030 valve to dump all suspension ride bags. PUSH DOWN to fill.

Lift Axle Down: With the red manual control knob up and electric power off, the lift ride bags will fill to the system pressure.

Lift Axle Up: Supply 12 volt DC power to the solenoid (the red knob must be up) OR manually push the control knob down and twist to lock.

Component List:

(A) - RA220-1 - Lift axle solenoid valve
(C) - RA510 - Pilot valve

(B) - RA030 - Suspension dump valve
(D) - RA001BS - Stainless steel box (only)

RA0122S LIFT AXLE CONTROL

25ANR, 25ART, 30ANR



RA012S Lift Axle Control

S/N - 2370900

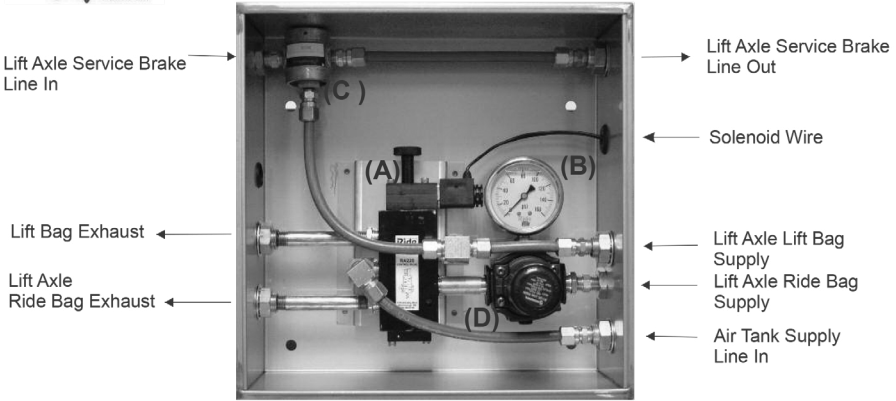

System Operation:

Lift Axle Down: With the red manual control knob up and electric power off, the lift ride bags will fill to the pressure set at the regulator.

Lift Axle Up: Supply 12 volt DC power to the solenoid (the red knob must be up) OR manually push the control knob down and twist to lock.

Component List:

- | | |
|--|--|
| (A) - RA220 - Lift axle solenoid valve | (B) - RA325LS - Pressure gauge 2-1/2" |
| (C) - RA510 - Pilot valve | (D) - RA611 - Regulator |
| (E) - RA002 - Rubber latch (not shown) | (F) - RA001BS - Stainless steel box (only) |

SUSPENSION CONTROL RA019SA - B150

53ET3X, 27LBT2X



RA019SA-B150 Suspension Control

S/N - 3561404
B150S/N - B1425-0089

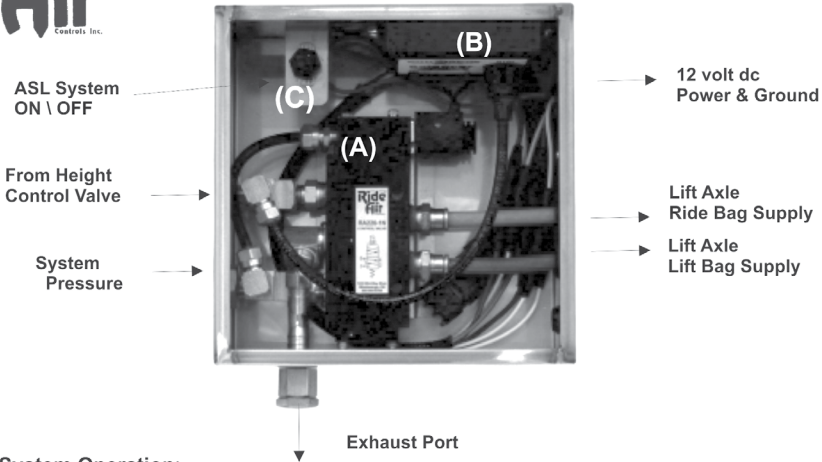

System Operation:

With Switch (C) on, the ASL (auto sensing lift) System will function automatically. Axle (s) will lift when the trailer is empty. Axle (s) will automatically lower when the trailer is loaded.

With the Switch (C) in the off position, all axles will remain down.

The B150 Balancer module is factory set to lift axle(s) when the trailer is unloaded and lower all axles when a load is detected. With the control knob down the lift axles will be locked up.

THE B150 CAN ONLY BE ADJUSTED BY AN AUTHORIZED DEALER

Component List:

- | | | |
|----------------|---------------------------|--|
| (A) - RA220-1N | - Lift Axle Control Valve | (B) RM-B150 - Balancer - Electronic Control Module |
| (C) - RP34-571 | - Toggle switch | (D) RA001TS - Stainless Steel Box |
| (D) - S110524 | - Exhaust Filter | |

HIGH LIFT CONTROL:

- To operate the high lift tailgate option supply 12 VDC to valve (D) or push the control knob down and twist to lock. Reverse operation to lower tailgate.

11.0 TROUBLE SHOOTING

PROBLEM	PROBABLE CAUSE	CORRECTIVE ACTION
COUPLER LOCK DOES NOT FULLY ENGAGE	Dirt or gravel contamination.	Wash and inspect.
	Worn parts.	Check fifth wheeling locking adjustment (see Maintenance Section).
	Mechanism improperly adjusted.	Check for excessive wear.
EXCESSIVE OR UNEVEN TIRE WEAR	Over or under inflation.	Inflate to recommended pressure.
	Loose wheel nuts or clamps.	Tighten wheel nuts or clamps to recommended torque.
	Loose or tight wheel bearing.	Adjust bearings.
	Axle bent or out of alignment.	Straighten, align or replace axle.
	Tires not properly matched.	Match tires.
	Improper acting brakes.	Correct brakes as required.
	Rapid stopping.	Apply brakes slowly when approaching stops.
	Excessive speed on turns.	Reduce speed.
	*See your tire dealer for any tire issues.	
SCUFFED TIRES	Over or under inflation.	Inflate to recommended pressure.
	Excessive speed on turns.	Reduce speed.
WOBBLY TIRES	Tire wobble due to uneven rim clamping.	Torque tighten all rim clamps.
	Worn or damaged wheel bearings.	Replace bearings.
	Broken or bent wheel or rim.	Replace wheel or rim.
	Bent axle.	Replace or straighten axle.
	Broken wheel studs.	Replace wheel studs.
DOG TRACKING	Blown air bag.	Replace air bag.
	Bent axle.	Replace or straighten axle.
	Frame or suspension (axles) out of alignment.	Straighten frame or align axles.
	Worn or damaged torque arms or bushings.	Check or replace.

PROBLEM	PROBABLE CAUSE	CORRECTIVE ACTION
LOSS OF TIRE AIR PRESSURE	Puncture in tire.	Repair or replace tire.
	Faulty valve or valve core.	Replace valve assembly or core.
	Wheel or rim damage.	Replace wheel or rim.
BRAKES DO NOT APPLY EVENLY	Brake valve(s) not operating correctly.	Check brake adjustment and related items.
	Loading of trailer not proportional.	Redistribute load.
BRAKES DO NOT RELEASE	Brake shoe bound up at anchor pins.	Lubricate brake operating parts.
	Brake hoses restricted.	Replace hoses.
	Brakes out of alignment.	Adjust brakes.
	Damaged brake assembly.	Replace damaged parts.
	Contaminated air valves.	Clean or replace.
	Tractor lines crossed.	Attach properly.
	NO BRAKES OR INSUFFICIENT BRAKES	Source of air supply shut off at tractor.
Disconnected or not properly coupled glad hands.		Connect or properly couple glad hands.
Lower brake line pressure.		Check air pressure gauge on tractor or for inoperative compressor.
Brake pads worn or glazed.		Replace pads.
Reservoir drain valve open.		Close drain valve.
GRABBING BRAKES		Oil, grease or foreign material on brake lining.
	Brakes out of adjustment.	Adjust brakes.
	Brake drum out-of-round.	Replace brake drum.
	Damaged brake chamber or internal assembly.	Replace complete brake chamber.
	Leaking or broken hose between valve and brake chamber.	Replace or repair as required.

PROBLEM	PROBABLE CAUSE	CORRECTIVE ACTION
BRAKES DRAGGING	Brakes set too tight.	Adjust brakes (slack adjuster).
	Binding cam, anchor pins or chamber rod end pin.	Lubricate and free up.
	Diaphragm is leaking in brake chamber.	Replace broken chamber.
	Air valve contamination.	Clean and replace.
	Damaged brake assembly or brake drum out of round.	Replace.
SLOW BRAKE APPLICATION OR RELEASE	Lack of lubrication.	Lubricate brake operating parts.
	Excessive travel in brake chamber push rod.	Adjust brakes.
	Restriction in hose or lines.	Repair or replace.
	Defective brake valve (s).	Replace defective valve(s).
ALL AIR SPRINGS FLAT	Insufficient air supply.	Build up and maintain tractor air pressure at least 85 psi.
		Check couplings and valves from tractor and trailer.
	Air spring leaking or punctured	Replace air spring.
	Leaking or broken air line in air suspension system.	Inspect and test for leaks or pinched lines, repair.
	Malfunctioning height control valve.	Inspect, test and replace as required.
ONE AIR SPRING FLAT	Air spring leaking or punctured.	Replace air spring.
	Supply lines pinched or broken.	Repair or replace.
AIR SUSPENSION DEFLATES RAPIDLY WHEN PARKED.	Leak in air system.	Locate and repair leak(s).
TRAILER RIDES TOO HIGH OR TOO LOW.	Improperly adjusted height control valve.	Check height and readjust height control valve.
	Faulty valve.	Inspect and repair.
	Control valve linkage broken or disconnect.	Inspect and repair.

PROBLEM	PROBABLE CAUSE	CORRECTIVE ACTION
EXCESSIVE SHOCK ABSORBER WEAR.	Defective height control valve.	Replace valve.
	Damaged air spring.	Replace air spring(s).
HEIGHT CONTROL VALVE NOT FUNCTIONING.	Dirt or foreign matter in air supply line.	Check and clean air filter. Inspect, clean or replace height control valve.
DIM OR FLICKERING LIGHTS.	Battery on tractor not sufficiently charged.	Charge battery.
	Bad connection.	Check electrical system circuits.
	Damaged wire in jumper cable.	Repair or replace cable.
	Poor ground sockets.	Repair as necessary.
COMPLETE LOSS OF TRAILER LIGHTS.	Broken main harness.	Repair or replace.
	Frayed wires.	Check circuit breaker at front.

12.0 WARRANTY

BWS Manufacturing Ltd. - Warranty Procedures

FOR ASSISTANCE, PLEASE CALL SERVICE

Monday - Friday

8:00am-5:00pm AST

Toll Free:1-888-896-5777

Local:1-506-391.5878

Email: warranty@bwstrailers.com

BWS CONTACT INFORMATION

29 Hawkins Road, Centreville, NB - E7K 1A4

For more information, contact the nearest BWS authorized dealer or visit www.bwstrailers.com where a warranty claim can be made.

12.1.1 STRUCTURAL & COMPONENT WARRANTY

1 YEAR BUMPER TO BUMPER	Warrants that the specified BWS equipment will be free from defects in materials and workmanship, under normal use and service, for the period of the first 12 months or regular service post the date-in-service. This warranty extends only to the original first owner. It is not transferable and applies only to OEM installed components and equipment.
3 YEAR PAINT AND FINISH	Steel Shot Blast Industrial top coat and oven baked finish is warrantied against defects in materials and workmanship (140 degrees for 75 minutes) Custom colours are subject to a 1 year warranty only Does not cover against general wear and tear such as stone chips or fade as of 2016.
5 YEAR SUPER STRUCTURE	Warrants the trailer main frame beams or "super structure" (consisting of the top and bottom flanges, and their connecting web) to be free from defects in materials and workmanship, under normal use and service for a period of 5 years from the date-in-service only to the original first owner.
SUSPENSION	Ridewell holds a 5 year warranty on all beams and bushings. Hutch has a 5 year warranty on manufacturer defects.
6 YEAR BRAKES	Haldex Platinum Warranty to the 1st owner Life Seal equipped Haldex ABS component brake system slack adjusters/brake chambers (Haldex LifeSeal)/ABS system ECM & control valve. 6 year or one (1) million mile warranty against defects in material or workmanship.
7 YEARS LIGHTING	Grote Ultra Blue 7 year warranty on the male pin harness 10 year warranty on tail lights

**No warranty what-so-ever on tires or ABS Sensor Alignment.

HALDEX WARRANTY

The Haldex warranty information can be found at www.haldex.com and then searching warranty, for your convenience.



HARD WORKING TRAILERS

FOR HARD WORKING PEOPLE



www.bwstrailers.com
toll free 888.896.5777



ISO 9001:2015
CERTIFIED